



# ***SIRMOD III***

## **Surface Irrigation Simulation, Evaluation and Design**

***Guide and Technical Documentation***

***Wynn R. Walker***

***Professor***

***Biological and Irrigation Engineering***

***Utah State University***

© Utah State University 2003

## Notice

This publication and its associated software may contain various typographical or programming errors which will be corrected as Utah State University becomes aware of them and incorporated in future revisions without notification.

The Biological and Irrigation Department at Utah State University does not guarantee the *SIRMOD III* for any specific use and does not assume any responsibility for its use. The program includes generally published procedures and algorithms for simulation, design, and evaluation of surface irrigations systems. However, the application of the software to a specific situation may be made where various combinations of parameters may violate the limits of these procedures and algorithms with the result that model output may contain errors in analysis or in general information.

Support of the *SIRMOD III* software can be obtained by written questions or comments directed to author at:

Dr. Wynn R. Walker  
Professor  
Department of Biological and Irrigation Engineering  
Utah State University  
4105 Old Main Hill  
Logan, UT 84322-4105  
Fax: (435) 797-1248  
E-mail: [wynnwalk@cc.usu.edu](mailto:wynnwalk@cc.usu.edu)

## TABLE OF CONTENTS

<b>Chapter 1. The Practice of Irrigation.....</b>	<b>1</b>
<b>INTRODUCTION .....</b>	<b>1</b>
<b>FUTURE TRENDS IN IRRIGATION .....</b>	<b>2</b>
<b>KEY ELEMENTS OF IRRIGATION WATER MANAGEMENT .....</b>	<b>3</b>
<b>SELECTING AN IRRIGATION METHOD .....</b>	<b>4</b>
<b>Compatibility .....</b>	<b>4</b>
<b>Economic Considerations.....</b>	<b>4</b>
<b>Topographic Limitations .....</b>	<b>5</b>
<b>Soil Characteristics.....</b>	<b>5</b>
<b>Water Supply.....</b>	<b>5</b>
<b>Crop Factors .....</b>	<b>6</b>
<b>External Influences.....</b>	<b>6</b>
<b>ADVANTAGES AND DISADVANTAGES OF SURFACE IRRIGATION.....</b>	<b>6</b>
<b>REFERENCES .....</b>	<b>7</b>
<b>Chapter 2. The Irrigation Requirement.....</b>	<b>8</b>
<b>INTRODUCTION .....</b>	<b>8</b>
<b>WATER BALANCE.....</b>	<b>8</b>
<b>SOIL CHARACTERISTICS .....</b>	<b>10</b>
<b>Soil Moisture.....</b>	<b>10</b>
<b>Infiltration .....</b>	<b>14</b>
<b>Soil Physical Properties.....</b>	<b>18</b>
<b>Soil Chemical Properties .....</b>	<b>18</b>
<b>CROP EVAPORATIVE AND DRAINAGE REQUIREMENTS .....</b>	<b>19</b>
<b>Evapotranspiration .....</b>	<b>19</b>
<b>Drainage Requirement.....</b>	<b>19</b>
<b>IRRIGATION EFFICIENCY AND UNIFORMITY .....</b>	<b>20</b>
<b>General Discussion .....</b>	<b>20</b>

<b>Application Uniformity and Efficiency</b> .....	20
<b>IRRIGATION REQUIREMENT</b> .....	23
<b>Chapter 3. Surface Irrigation Systems</b> .....	25
<b>INTRODUCTION</b> .....	25
<b>TYPES OF SURFACE SYSTEMS</b> .....	26
<b>Basin Irrigation</b> .....	26
<b>Border Irrigation</b> .....	27
<b>Furrow Irrigation</b> .....	29
<b>WATER SUPPLY AND MANAGEMENT</b> .....	29
<b>Inlet Discharge Control Practices</b> .....	29
<b>Field Surface Amendments</b> .....	30
<b>Wastewater Recovery and Reuse</b> .....	31
<b>STRUCTURAL ELEMENTS</b> .....	32
<b>Diversion Structures</b> .....	32
<b>Conveyance and Management Structures</b> .....	33
<b>Field Distribution Systems</b> .....	33
<b>REFERENCES</b> .....	36
<b>Chapter 4. Field Measurement Techniques</b> .....	37
<b>INTRODUCTION</b> .....	37
<b>FIELD PROCEDURES AND MEASUREMENTS</b> .....	37
<b>General Field Evaluation Procedure</b> .....	37
<b>Advance and Recession Measurements</b> .....	39
<b>ADVANCE PHASE</b> .....	39
<b>WETTING PHASE OR PONDING</b> .....	41
<b>DEPLETION PHASE</b> .....	41
<b>RECESSION PHASE</b> .....	41
<b>Infiltration</b> .....	43
<b>CYLINDER INFILTROMETER</b> .....	43
<b>PONDING METHODS</b> .....	45

INFLOW-OUTFLOW METHODS.....	45
BLOCKED FURROW METHOD.....	46
RECYCLING FURROW INFILTROMETER .....	47
<b>Soil Moisture</b> .....	49
<b>Bulk Density</b> .....	50
<b>Field Capacity</b> .....	50
<b>Permanent Wilting Point</b> .....	50
<b>ANALYSIS OF FIELD DATA</b> .....	51
<b>Flow Shape</b> .....	51
<b>Calibrating Infiltration from Advance Data</b> .....	54
<b>Adjusting Infiltration for Wetted Perimeter</b> .....	55
<b>Adjusting Infiltration Parameters for Furrow Irrigation</b> .....	55
<b>Adjusting Infiltration Parameters for Flowrate</b> .....	56
<b>General Comment</b> .....	56
EVALUATION OF PERFORMANCE MEASURES.....	57
REFERENCES .....	58
<b>APPENDIX 4</b> .....	<b>59</b>
<b>TABLE 4.1. FORMAT FOR RECORDING WATER ADVANCE AND RECESSON DATA ON FURROW-IRRIGATED FIELDS</b> .....	59
<b>TABLE 4.2. FORMAT FOR RECORDING WATER ADVANCE, PONDING, DEPLETION, AND RECESSON DATA ON BORDER AND BASIN-IRRIGATED FIELDS</b> .....	60
<b>TABLE 4.3. FORMAT FOR RECORDING FURROW CROSS-SECTIONAL DATA</b> .....	61
<b>TABLE 4.4. FORMAT FOR RECORDING CYLINDER INFILTROMETER DATA.</b> .....	62
<b>TABLE 4.5. ESTIMATING SOIL MOISTURE STATUS BY THE TOUCH-AND-FEEL METHOD</b> .....	63
<b>Chapter 5. Design of Surface Irrigation Systems</b> .....	<b>65</b>

<b>THE OBJECTIVE AND SCOPE OF SURFACE IRRIGATION DESIGN.....</b>	<b>65</b>
<b>THE BASIC DESIGN PROCESS.....</b>	<b>66</b>
<b>The Preliminary Design .....</b>	<b>66</b>
<b>Detailed Design .....</b>	<b>67</b>
<b>TWO BASIC DESIGN COMPUTATIONS.....</b>	<b>68</b>
<b>Computation of Advance Time .....</b>	<b>68</b>
<b>Computation of the Cutoff Time.....</b>	<b>70</b>
<b>SURFACE IRRIGATION SYSTEM DESIGN .....</b>	<b>70</b>
<b>Input Data for the Surface Irrigation Design Process.....</b>	<b>71</b>
<b>Free Draining Surface Irrigation Design .....</b>	<b>71</b>
<i>Free Draining System Design Procedure.....</i>	<i>71</i>
<b>Blocked-end Surface Irrigation Design.....</b>	<b>73</b>
<i>Introduction.....</i>	<i>73</i>
<i>Selecting the Field Control Point .....</i>	<i>75</i>
<i>Selecting the Cutoff Time.....</i>	<i>75</i>
<i>Selecting the Inflow Rate.....</i>	<i>75</i>
<i>Checking Design Limitations.....</i>	<i>76</i>
<b>Design Procedure for Cutback Systems.....</b>	<b>77</b>
<b>Design of Systems with Tailwater Reuse .....</b>	<b>77</b>
<i>Input Data.....</i>	<i>78</i>
<i>Design of Reuse Systems for Recycling on Another Field .....</i>	<i>78</i>
<i>Design of Reuse Systems for Recycling on the Same Field.....</i>	<i>80</i>
<b>Design of Surge Flow Systems.....</b>	<b>81</b>
<b>Chapter 6. Simulation of Surface Irrigation Systems .....</b>	<b>82</b>
<b>SURFACE IRRIGATION'S GOVERNING EQUATIONS.....</b>	<b>82</b>
<b>AN OVERVIEW OF THE NUMERICAL SOLUTION .....</b>	<b>82</b>
<b>Writing the Continuity Equation in Its Eulerian Form.....</b>	<b>84</b>
<b>Writing the Momentum Equation in Its Eulerian Form.....</b>	<b>85</b>
<b>THE NUMERICAL SOLUTION.....</b>	<b>86</b>
<b>Initial Conditions.....</b>	<b>87</b>
<b>Solutions During the Advance Phase .....</b>	<b>88</b>
<b>Downstream Boundary Conditions at the End of the Advance Phase .....</b>	<b>91</b>

<b>Chapter 7. The SIRMOD III Concept.....</b>	<b>93</b>
OVERVIEW.....	93
GETTING STARTED.....	93
SPECIAL FEATURES .....	94
<b>Units .....</b>	<b>94</b>
<b>Language.....</b>	<b>95</b>
<b>Conventions .....</b>	<b>95</b>
<b>Chapter 8. Running The SIRMOD III Software .....</b>	<b>96</b>
DATA INPUT .....	96
<b>Entering Field Characteristics.....</b>	<b>96</b>
<b>Field Geometry and Topography.....</b>	<b>97</b>
<b>Infiltration Functions.....</b>	<b>97</b>
<b>Flow cross-section.....</b>	<b>99</b>
ENTERING MODEL CONTROL PARAMETERS.....	100
<b>Type of Simulation Model.....</b>	<b>100</b>
<b>Simulation Cutoff Control.....</b>	<b>100</b>
<b>Inflow Regime.....</b>	<b>101</b>
<b>Flow control parameters.....</b>	<b>101</b>
<b>Special numerical coefficients.....</b>	<b>101</b>
FILE MANIPULATION.....	101
SIMULATION.....	101
EVALUATION .....	103
DESIGN.....	103
<b>Volume Balance Design .....</b>	<b>104</b>
<b>Field Adaptation.....</b>	<b>105</b>
<i>Design Slope and Maximum Velocity.....</i>	<i>105</i>
<i>Required Depth of Application.....</i>	<i>105</i>
<i>Field Layout .....</i>	<i>105</i>
<b>Output .....</b>	<b>106</b>
<i>Printed Output.....</i>	<i>106</i>
<i>Plotted Output .....</i>	<i>107</i>
<b>Chapter 9. Surge Flow .....</b>	<b>109</b>

<b>CONCEPTUAL DEVELOPMENT.....</b>	<b>109</b>
<b>DEVELOPMENT OF SURGE FLOW SIMULATION MODELS .....</b>	<b>110</b>
<b>Verification Data .....</b>	<b>111</b>
<b>Model Modification and Verification.....</b>	<b>114</b>
<b>SURGE FLOW MANAGEMENT .....</b>	<b>118</b>
<b>Management Strategies .....</b>	<b>119</b>
<b>The Flowell Case Study .....</b>	<b>120</b>
<b>SUMMARY .....</b>	<b>124</b>
<b>REFERENCES .....</b>	<b>124</b>
<b><i>Chapter 10. Land Leveling .....</i></b>	<b><i>126</i></b>
<b>INTRODUCTION .....</b>	<b>126</b>
<b>GENERAL CONSIDERATIONS .....</b>	<b>126</b>
<b>SMALL-SCALE LAND LEVELLING .....</b>	<b>127</b>
<b>LARGE SCALE LAND LEVELING .....</b>	<b>128</b>
<b>TRADITIONAL LAND LEVELING PROCESS.....</b>	<b>129</b>
<b>Land Survey and Mapping.....</b>	<b>130</b>
<b>Selecting Field Slopes.....</b>	<b>131</b>
<b>Example Field Slope Computations .....</b>	<b>133</b>
<b>Adjusting Cut/Fill Ratios .....</b>	<b>135</b>
<b>Computing Cut Volumes for Contractors .....</b>	<b>136</b>
<b>OTHER CONSIDERATIONS.....</b>	<b>136</b>
<b>Field Subdivision.....</b>	<b>136</b>
<b>Field Operations.....</b>	<b>137</b>
<b>Miscellaneous Earth Requirements .....</b>	<b>138</b>
<b>Maintenance .....</b>	<b>138</b>
<b>REFERENCES .....</b>	<b>138</b>

---

## Chapter 1. The Practice of Irrigation

---

### INTRODUCTION

In 1996 various heads of state and government officials were invited to Rome at the behest of FAO to attend the “World Food Summit”. As part of the summit, these officials adopted the “Rome Declaration on World Food Security” which included the following statement: “...reaffirmed the right of everyone to have access to safe and nutritious food, consistent with the right to adequate food and the fundamental right of everyone to be free from hunger” (FAO, 1996a).

The term used to assess whether or not this right is available is “food security”. In 1995, the U.S. Agency for International Development defined food security as: “People are “food secure” when they have regular access (either through production or purchasing power) to sufficient food for a healthy and productive life” (USAID, 1995).

At the 1996 “World Food Summit” in Rome, one of the technical background papers on the relationships between food security and water security stated:

*“Security and stability in food supplies in the next century will be closely linked to success in water control. Moisture control at root level allows for the maximization and stabilization of production by ensuring that fluctuations in the rainfall regime do not result in stress to the crop, thus fully realizing the benefits of high-yielding varieties and plant nutrition and protection systems. Success will not come merely from expansion (more rivers dammed, more canals built, larger tracts of land leveled and watered). Increasingly, it must come from improved management: rehabilitation of inefficient systems and substitution of traditional systems stemming from a past era of plenty for systems based on accurate technology. Achieving this will require on the one hand funds, and on the other, qualified, capable farmers and managers.” (FAO 1996b)*

The expansion of the global arable land resource has slowed dramatically since 1950, from about 0.60 ha/person in 1950 to about 0.25 ha/person in 2000. At the same time, the expansion in irrigated agriculture has paralleled population growth since 1950. A summary of several analyses by Howell (2000) shows that per capita irrigated area has remained nearly constant at 0.045 ha/person but is now beginning to decline. These statistics taken together indicate that while the importance of irrigated agriculture has grown relative to the non-irrigated sector, future irrigation developments will be limited. The FAO (1996b) report concluded that 17 percent of the global agricultural land that was being irrigated. These approximately 250 million hectares produce almost 40 percent of the total global food supply. The dependency on irrigated production is more severe in some regions. FAO (1996b) and Brown (1999) reports that 90 percent of the food production in Pakistan, 70 percent in China and 50 percent in India are harvested from irrigated land. Some countries in Sub-Saharan Africa, Latin America and the Caribbean may have as little as 10-15 percent of their food supply dependent on irrigated land. In the United States the irrigated fraction has now reached 18 percent (US Department of Commerce, 1999), but this relatively small area produces 50 percent of the total value of U.S. cropland production.

---

<sup>1</sup> Taken from Walker and Skogerboe (1987), and Walker (1989).

Historically, civilizations have been dependent on the development of irrigated agriculture to provide the agrarian basis of a society and to enhance the security of their people. When the constraints of the complex soil-water-plant relationship were ignored either through ignorance or lack of planning, the productivity of irrigated agriculture declined. The ancient civilization of Mesopotamia flourished in the Tigris-Euphrates Valley 6000 years ago (Kang, 1972) and then floundered when the soil became saline due to poor irrigation practices and a lack of drainage. It has been estimated that 6000 years ago the Tigris-Euphrates Valley supported as many as 25 million persons. Iraq, which presently occupies much of this same area, today has a population of about 14 million. In fact, the tax records from Mesopotamia show that barley yields were about two to four times present yields in this area (Kovda et al., 1973).

When a reliable and suitable supply of water becomes available for agriculture it can result in vast improvements in agricultural production and assure economic returns to the grower. Effective agronomic practices must be included, such as fertilization and crop rotation. Soil reclamation and management, erosion control, and drainage practices must be developed for the local conditions and applied rigorously. But water management, delivering water to the farms and on the farm itself, is the key to successful irrigation projects.

### ***FUTURE TRENDS IN IRRIGATION***

The International Commission on Irrigation and Drainage, comprised of 69 member countries, adopted a joint declaration in 1999 that stated (Hargreaves, 2000):

*“Irrigation, drainage and flood control of agricultural lands are no longer options. They are necessary for feeding billions of people, for employment for rural poor, and for protecting the environments...A balance needs to be found between the requirements based on the needs of society, acceptable side effects and a sustainable environment”.*

The sustainability of both the irrigated and non-irrigated sectors is, however, problematic. Both sectors have adverse impacts on the quality of local receiving waters due to soil erosion and nutrient/pesticide leaching. If global warming seriously disrupts precipitation patterns, both sectors may experience substantial losses in productivity. Sustainability of the irrigated sector is perhaps threatened more by poor management than the vagaries of nature. Rhoades (1997) reported estimates that as much as 20 percent of the irrigated land may already be experiencing yield declines due to poor drainage (waterlogging and salinization) caused by over-irrigation. FAO (1996b) estimates that that approximately 70 percent of initial fresh water withdrawals are allocated to agriculture where irrigation is the predominant agricultural use. Overall project efficiency may be as low as 40 percent. Stated in other terms, about 2.5 times the amount of water needed for optimal crop production is being diverted for agriculture thereby limiting the water resources available for urbanization and industrialization. As the fresh water supplies come under increasing demand from these other sectors, irrigated agriculture cannot be this inefficient.

Taken as a whole, it is clearly evident that future population growth will not be entirely met with the same strategies that satisfied growth during the last half-century.. Limited irrigation developments through small and medium sized dams, conjunctive use of aquifers, water harvesting, etc. are still possible. In fact, FAO (1996b) is so bold as to estimate that irrigated area can be increased almost 60% (about 110 million hectares, mostly in Asia). The problem is that these opportunities are limited and extremely expensive. For instance, the cost of developing these 110 million hectares is estimate to be as high as \$1.0 trillion and would only provide a

basic diet for an additional 1.5-2.0 billion people – the expected population increase over the next 25 years. Even more problematic according to Seckler et al. (1998) is the lack of water. They examined the availability of water resources for the first 25 years of the 21<sup>st</sup> century and concluded that only 50 percent of the new demands could be met with technical interventions and new projects. The remaining 50 percent would have to be met by non-technical means such as better and more efficient water management, which, while relying on some technical interventions such as rehabilitation, depend primarily upon the training and will of skilled water users and effective water management institutions.

Thus, the role of agricultural water management strategies in the food security strategies of the next 25 years is critical. The expense and lack of water for developing new lands means that existing lands served by existing systems from existing water resources must become more productive. This can only occur if lands, water resources, and systems are managed, maintained, and sustained more effectively and more efficiently. Under this scenario, the most important “resources” to be “developed” and “sustained” for future growth are human resources and the institutions that manage and control water resource systems

### ***KEY ELEMENTS OF IRRIGATION WATER MANAGEMENT***

Irrigation in arid areas of the world has two primary objectives: (1) to supply the essential moisture for plant growth, which includes the transport of essential nutrients; and (2) to leach or dilute salts in the soil. Irrigation provides a number of side benefits, such as cooling the soil and the atmosphere to create a more favorable environment for plant growth. Irrigation supplements the supply of water received from precipitation and other types of atmospheric water, floodwaters, and groundwater.

The method and timing of irrigations have significant effects on crop production. Annual crops may not germinate if the irrigation method causes a crust over the seedbed. Once established, the stress created by soil moisture tensions can often severely affect yields if they occur during critical periods. Thus, while the first objective of irrigation is to replenish the soil moisture reservoir, the method and its management are important considerations.

Salts are contributed to the irrigation system by two main processes: salt concentration and chemical weathering. Salt concentration effects occur in the soil due to the removal of water by the consumptive use of crops and other natural vegetation. Irrigation along with the inter-basin export of high-quality water and evaporation from the water surfaces of streams and lakes are major causes of increased salinity levels caused by concentrating effects. Salts may also accumulate in the soil by the chemical weathering of soil and substrata by irrigation water and natural subsurface flows. Also known as "salt loading," it contributes to the concentrations in water supplies along with excessive fertilizer applications, municipal and industrial wastes, and point sources such as mineral springs, flowing brine wells, and geysers.

If the salts accumulating in the root zone as a result of evapotranspiration or weathering are not periodically leached from the crop root zone, the land will become unproductive. However, the water which passes through the root zone carrying the excess salts may be severely restricted from further travel by subsurface conditions. When this occurs, this leachate will eventually build up into the root zone, causing high salinity levels and poor aeration (waterlogging). In many areas, drainage is more than adequate and the movement of salts from irrigated lands contaminates local groundwater basins and stream flows.

Another serious environmental problem associated with irrigated agriculture is the erosion of topsoil and soil nutrients by tailwater into the reservoirs, canals, and laterals of downstream users. Siltation reduces the capacities of drainage and irrigation channels, resulting in costly large-scale maintenance programs and the installation of expensive structures for its removal. The useful lifetime of dams and reservoirs is often computed in terms of the rate of sedimentation.

In view of the needs for irrigation-to increase food and fiber production with all the associated consequences to the stability of a society, as well as the potential for adverse environmental effects, the technology of irrigation is more complex than many nonprofessionals appreciate. It is important that the scope of irrigation engineering not be limited to diversion and conveyance system nor solely to the irrigated field, but rather the "irrigation engineer" should integrate the delivery, farm, and drainage subsystems into a cohesive discipline.

Irrigation management is often designed to maximize efficiencies and minimize the labor and capital requirements of that particular irrigation system while maintaining a favorable growing environment for the plant. Some managerial inputs are dependent on the type of irrigation system and the design of the system. For example, the degree of automation, the type of system (sprinkle, trickle, or surface irrigation), the reuse of field tailwater, soil type, topographical variations in a field or farm, and the existence and location of management tools such as flow measurement and water control structures can influence the managerial decision making process.

However, management decisions which are common to all systems, regardless of the types, are the frequency of irrigation, depth of water to be applied, and measures to increase the uniformity of applications such as land leveling or shaping. In addition, individual systems can be manipulated to greatly increase application efficiencies. For example, in furrow irrigation some growers will use two siphon tubes per furrow at the start of irrigation (advance phase) and when the water has reached the end of the row, one tube is removed (wetting phase). This increases the efficiency by minimizing field tailwater runoff, but it requires an additional labor input.

### ***SELECTING AN IRRIGATION METHOD***

There are a large number of considerations which must be taken into account in the selection of an irrigation system. These factors will vary in importance from location to location and crop to crop. Briefly stated, these considerations include the compatibility of the system with other agricultural operations, economic factors, topographic limitations, soil properties, and several agronomic and external influences.

#### **Compatibility**

The irrigation system for a field or a farm must be compatible with the other existing farm operations, such as land preparation, cultivation, and harvesting practices. For instance, the use of the more efficient, large machinery requires longer and wider fields and even perhaps removable irrigation systems.

#### **Economic Considerations**

The type of irrigation system selected is also an economic decision. Some types of sprinkle systems have high per-acre costs and their use is therefore limited to high-value crops. Other

systems have high labor requirements, and some have fairly high operating costs. Some systems have limitations with respect to the type of soil or the topography on which they can be used. The expected life of the system, fixed costs, and annual operation costs (energy, water depreciation, land preparation, maintenance, labor, taxes, etc.) should also be included in the analysis when selecting an irrigation system.

In considering the economics of irrigation systems it must be kept in mind that the system yielding the highest return is a compromise between the four resources of labor, water, land, and capital. Within limits, each can be traded for the other, with only a marginal change in the gross return of the systems. Thus water can be saved in a surface irrigation system if more labor or labor of greater skill is used to apply the water.

### **Topographic Limitations**

Restrictions on irrigation system selection due to topography include groundwater levels, the location and relative elevation of the water source, field boundaries, acreage in each field, the location of roads and natural gas lines, electricity and water lines and other obstructions, the shape of the field, and the field slope (which can vary dramatically over a field). Field surface conditions such as relative roughness and gullies should also be considered.

The slope of the land is very important. Some types of sprinklers can operate on slopes up to 20% or more, but furrow or graded border irrigation is usually limited to a maximum slope of around 2 to 6%. Trickle irrigation can be used on slopes up to 60%.

The shape of a field also determines the type of system. For instance, level borders, furrows, hand-move or solid-set sprinklers, subsurface, contour ditch, or trickle irrigation systems can be adjusted to fit almost any field shape; whereas a center-pivot sprinkler must have approximately square-shaped fields. For a side roll sprinkler, level furrow, graded border, or contour furrow, the field should be approximately rectangular in shape.

### **Soil Characteristics**

The soil type, soil moisture-holding capacity, the intake rate, and effective soil depth are also criteria which enter into the type of system selected. For example, sandy soils have a high intake rate and will accept high-volume sprinklers which would be unacceptable on a tight clay soil.

The moisture-holding capacity will influence the size of the irrigation sets and frequency of irrigations, as evidenced by a sandy soil with low moisture-holding capacity, which requires frequent, light applications of water. A center-pivot or side roll sprinkler or even a trickle irrigation system would perform satisfactorily in this case.

A number of other soil properties are also significant factors in considering the type of irrigation system that will be most advantageous in a particular situation. The interaction of water and soils due to physical, biological, and chemical processes has some influence on the hydraulic characteristics and tilth. Crusting and erodibility should be considered in each irrigation system design, and the spatial distribution of soil properties may be an important limitation on some methods of applying irrigation water.

### **Water Supply**

The quality, quantity, and temporal distribution characteristics of the source of irrigation water have a significant bearing on the irrigation practice. Crop water demands are essentially

continuous during the growing season, although varied in magnitude. A small, readily available water supply is best utilized in a small capacity irrigation system which incorporates frequent applications. The depths applied per irrigation are therefore small in comparison to systems having a large discharge available less frequently.

The quality of water in conjunction with the frequency of irrigations must be evaluated. Salinity is generally the most significant problem, although other elements, such as boron, can be important. A highly saline water supply must be applied more frequently and in larger amounts than good-quality water.

### **Crop Factors**

Some of the factors associated with the crops being grown which influence the choice of irrigation system and its eventual management are summarized by Corey and Hart (1974):

1. The tolerance of the crop during both development and maturation to soil salinity, aeration, and various substances, such as boron
2. The magnitude and temporal distribution of water needs for maximum production
3. The economic value of the crop

In each case, the allowable investment in the system and the crops which can be irrigated by a specific system are affected by these crop factors.

### **External Influences**

At times, the selection of an irrigating method may be dictated by considerations somewhat unrelated to agriculture. The irrigation project may be designed from the reservoir to the turnout without regard to what is needed at the farm and thereby force a method of irrigation on the farmers. National concerns about foreign exchange and expatriate consultation may limit import of alternative technologies, and local fabrication capacities may not be adequate. Thus it is easy to find countries where trickle irrigation could be used economically but is prevented by policy. Some methods may be embedded culturally and used regardless of suitability.

### ***ADVANTAGES AND DISADVANTAGES OF SURFACE IRRIGATION***

The term "surface irrigation" refers to a broad class of irrigation methods in which water is distributed over the field by a free-surface, gravity flow. A flow is introduced at a high point or along a high edge of the field and allowed to cover the field by overland flow. The rate of coverage is dependent almost entirely on the quantitative differences between inlet discharge and the accumulating infiltration. Secondary factors include field slope and length as well as surface roughness.

The practice of surface irrigation is thousands of years old and collectively represents by far the most common irrigation activity today. The easiest water supplies to develop have been stream or river flows which required only a simple river dike and canal to provide water to adjacent lands. These low-lying soils were typically high in clay and silt content and had relatively small slopes. A comparison of irrigation methods at various historical junctures would lead to differing conclusions, but some general advantages and disadvantages of surface irrigation can be outlined.

As alluded to above, surface irrigation systems can be developed with minimal capital investment, although these investments can be very large if the water supply and irrigated fields

are some distance apart. At the farm level and even at the conveyance and distribution levels, surface irrigation systems need not require complicated and expensive equipment. Labor requirements for surface irrigation tend to be higher than for the pressurized types, but the labor still need not be high unless maximum efficiencies are sought. However, when water supplies are short, irrigators have developed highly skilled practices which achieve high efficiencies. With the variety of irrigation systems in use today, it is difficult to conclude whether operation and maintenance costs are necessarily lower with surface methods. Generally, energy costs are substantially lower, but inefficiency may very well reverse this factor.

On the negative side, surface irrigation systems are typically less efficient in applying water than either sprinkle or trickle systems. Since many are situated on lower lands with tighter soils, surface systems tend to be more affected by waterlogging and salinity problems. The need to use the field surface as a conveyance and distribution facility requires that fields be well graded. Land leveling costs are high, so the surface irrigation practice tends to be limited to land already having small, even slopes.

## **REFERENCES**

- Corey, A. T., and W. E. Hart. 1974. Soil-Water Engineering. Undergraduate class notes copyrighted by the authors while at the Department of Agricultural Engineering, Colorado State University, Fort Collins, Colo.
- Brown, L. R. 1999. Feeding Nine Billion. In L. Stark (ed) State of the World 1999. W. W. Norton & Co. New York. Pp 115-132.
- Food and Agriculture Organization of the United Nations. 1996a. Proceedings of the World Food Summit. November 13-17, 1996. FAO Rome, Italy.
- Food and Agriculture Organization of the United Nations. 1996b. Proceedings of the World Food Summit, Vol. 2, Chapter 7, "Food production: the critical role of water." Technical background document, November 13-17, 1996. FAO Rome, Italy.
- Israelsen, O. W., V. E. Hansen, and G. E. Stringham. 1980. *Irrigation Principles and Practices*, 4th ed. John Wiley & Sons, Inc., New York.
- Hargreaves, George H. 2000. Food, Water, and a Possible World Crisis. Paper presented at the 4<sup>th</sup> Decennial National Irrigation Symposium of the American Society of Agricultural Engineers. Phoenix, Arizona. November 14-21, 2000.
- Howell, T. A. 2000. Irrigation's Role in Enhancing Water Use Efficiency. Paper Presented at the National Irrigation Symposium, Phoenix, Arizona.
- Kang, S. T. 1972. Irrigation in Ancient Mesopotamia. *Water Resour. Bull.* 8(3):619-624.
- Kovda, V. A., C. VANDENBERG, and R. M. HAGAN (eds.). 1973. *Irrigation, Drainage and Salinity. An International Source Book*. United Nations, Food and Agriculture Organization, Rome.
- Rhodes, J. D. 1997. Sustainability of Irrigation: An Overview of Salinity Problems and Control Strategies. In. CWRA 1997 Annual Conference, "Footprints of Humanity: Reflections on Fifty Years of Water Resource Developments," Lethbridge, Alberta, Canada, June. pp. 1-42.
- Seckler, D., U. Amarasinghe, D. Molden, R. deSilva, and R. Barker. 1998. World Water Demand and Supply, 1990 to 2025: Scenarios and Issues. IIMI Research Report No. 19, International Irrigation Management Institute, Colombo, Sri Lanka.
- U.S. Agency for International Development. 1995. Food Aid and Food Security Policy Paper. Bureau for Program and Policy Coordination. Washington, D.C. February.
- U.S. Department of Commerce. 1999. 1997 Census of Agriculture. Washington, D. C.

---

## ***Chapter 2. The Irrigation Requirement<sup>2</sup>***

---

### ***INTRODUCTION***

The irrigation system is usually not expected to supply all of the moisture required for maximum crop production. To do so would ignore the valuable contribution of other water sources such as rain and thereby force the irrigation system to be larger and more expensive than necessary. It is also unrealistic that irrigation can or should be practiced without waste. Certainly, the fraction of that supplied which is beneficially used should be maximized, but this fraction or irrigation efficiency cannot be 100% without other serious problems developing.

In arriving at the contribution an irrigation system will make to an irrigated area, particularly a surface irrigation system, four major factors require consideration. These are:

1. The concept of water balance in the region encompassing the plant environment.
2. The body of soil supplying moisture, nutrient, and anchorage for the crop and the associated characteristics of this porous medium.
3. The crop water requirements, including drainage for aeration and salt leaching.
4. The efficiency and uniformity of the irrigation system.

### ***WATER BALANCE***

The employment of a water balance is a useful concept for characterizing, evaluating, or monitoring any irrigation system. A schematic of the water balance parameters used for characterizing a surface-irrigated field is shown in Fig. 2.1. The terms are defined as:

- $D_a$  = depth of applied irrigation water
- $D_{\Delta s}$  = depth of change in soil moisture storage in the root zone where  $D_{\Delta s}$  is positive for increasing soil moisture storage
- $D_{dp}$  = depth of deep percolation
- $D_e$  = depth of evaporation from soil surface or ponded water surface
- $D_{et}$  = depth of evapotranspiration
- $D_{gw}$  = depth of capillary rise from the groundwater table entering the root zone
- $D_p$  = depth of precipitation
- $D_{pl}$  = depth of precipitation intercepted by the plants (crop)
- $D_{pr}$  = depth of precipitation that occurs as surface runoff
- $D_{pz}$  = depth of precipitation that infiltrates into the soil
- $D_t$  = depth of transpiration from plants
- $D_{tw}$  = depth of tailwater (surface) runoff resulting from overland flow of the irrigation water supply
- $D_z$  = depth of infiltrated water resulting from overland flow of the irrigation

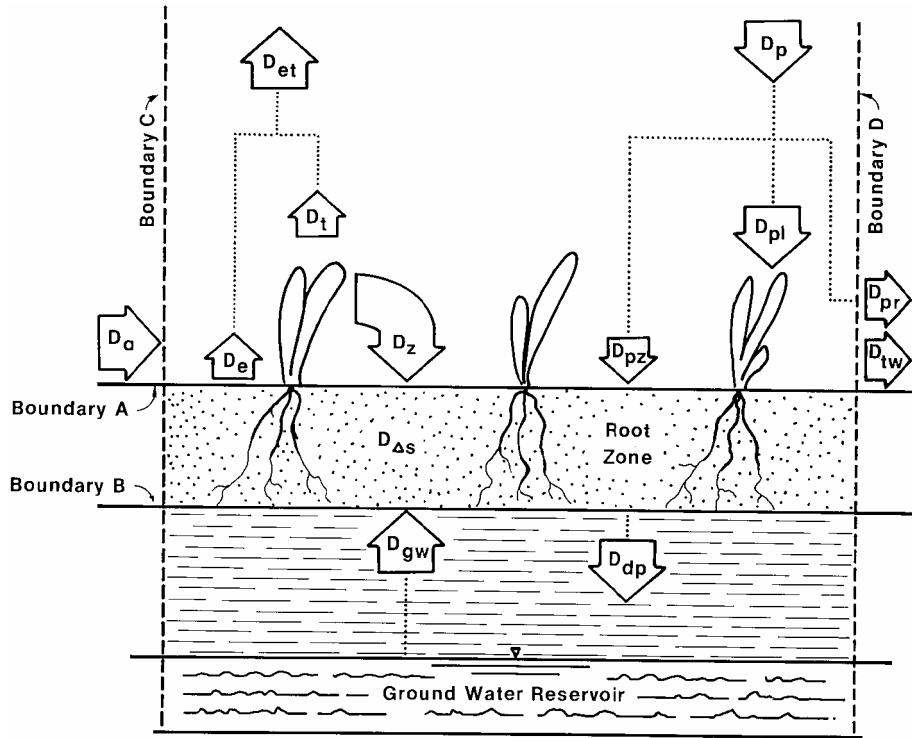
There are two additional terms that are useful to define at this point:

---

<sup>2</sup> Taken from Walker and Skogerboe (1987), and Walker (1989).

$D_{pn}$  = depth of net precipitation, or the depth of precipitation that is made available to the plant system

$D_d$  = depth of drainage requirement for maintaining a salt balance in the root zone



**Figure 2.1 The water balance parameters for a surface-irrigated field.**

The principle of continuity requires that inflow (I) minus outflow (O) equals the change in storage ( $\Delta S$ ) within the defined boundaries of a system:

$$I - O = \Delta S \quad (2.1)$$

Of primary concern in surface irrigation are boundaries A, B, C, and D as shown in Fig. 2.1, for which the continuity equation can be written as

$$\underbrace{(D_a + D_{gw} + D_p)}_{\text{inflows}} - \underbrace{(D_{et} + D_{pr} + D_{tw} + D_{dp} + D_{pl})}_{\text{outflows}} = D_{\Delta s} \quad (2.2)$$

in which

$$D_a = D_z + D_{tw} \quad (2.3)$$

$$D_p = D_{pz} + D_{pl} + D_{pr} \quad (2.4)$$

and

$$D_{et} = D_e + D_t \quad (2.5)$$

One of the most difficult water balance parameters to measure in the field is the deep percolation,  $D_{dp}$ . Consequently, this parameter is usually the dependent variable in evaluating the water balance for an irrigated field. Rearranging Eq. 2.2 and solving for  $D_{dp}$ , we have

$$D_{dp} = D_a + D_{gw} + D_p - D_{pr} - D_{et} - D_{tw} - D_{\Delta s} - D_{pl} \quad (2.6)$$

In using the water balance, an important consideration is the time frame in which the computations are made, that is, whether the balance will use annual data, seasonal data, or data describing a single irrigation event. If a mean annual water balance is computed, it becomes reasonable that the change in root zone soil moisture storage,  $D_{\Delta s}$ , could be assumed as zero, thereby eliminating  $D_{\Delta s}$  from Eq. 2.6. In some irrigated areas, precipitation events are so light that the net rainfall ( $D_{np} = D_p - D_{pr}$ ) can reasonably be assumed as equal to the measured precipitation, and  $D_{pr}$  can be neglected. Under other circumstances, other terms in Eq. 2.6 can be neglected. In fact, time periods are often selected to eliminate as many of the parameters as possible in order to identify the behavior for single parameters. The elimination of parameters from the water balance computations will result in more accurate predictions of deep percolation,  $D_{dp}$  (or any parameter in the water budget used as the dependent parameter). For instance, the groundwater contributed to the root zone soil moisture,  $D_{gw}$ , can usually be ignored if the groundwater table is more than 3 m below the ground surface.

## **SOIL CHARACTERISTICS**

Soil characteristics of particular importance to irrigated agriculture include (1) the capacity of the soil to hold water and still be well drained; (2) the flow characteristics of water in the soils; (3) the physical properties of the soil matrix, including the organic matter content, soil depth, soil texture, and soil structure; and (4) soil chemical properties, including the translocation and concentration of soluble salts and nutrients due to the movement, use, and evaporation of the soil water. Knowledge of all these relationships and how they influence each other is critical to all who desire to improve irrigation practices and obtain the best, most efficient use of water.

### **Soil Moisture**

If there is either excessive water (waterlogging) or insufficient water, crop growth will be retarded. As commonly defined, the available moisture for plant use is the range of soil moisture held at a negative apparent pressure of one-tenth to one-third bar (field capacity) and 15 bar (permanent wilting point). However, the soil moisture content within this pressure range will vary from 25 cm per meter of soil depth for some silty loams to as low as 6 cm per meter for some sandy soils.

A simplified schematic of a unit volume of soil, which contains solids (soil particles), liquid (water), and gas (air), is shown in Fig. 2.2. The porosity, ( $\phi$ ), of the unit volume is

$$\phi = \frac{V_p}{V} \quad (2.7)$$

The volumetric water content,  $\theta$ , is

$$\theta = \frac{V_w}{V} \quad (2.8)$$

The saturation,  $S$ , which is the portion of the pore space filled with water, is

$$S = \frac{V_w}{V_p} \quad (2.9)$$

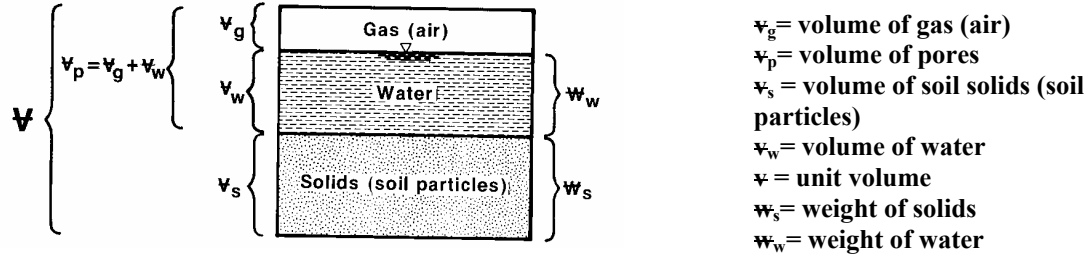


Figure 2.2 Simplified schematic of a unit volume of soil.

These terms are related by the expression

$$\theta = S\phi \quad (2.10)$$

Whenever field soil moisture samples are collected and the samples oven-dried, the soil moisture is reported as a percentage of the dry weight of the soil sample:

$$W = \frac{\text{sample wet wt.} - \text{sample dry wt.}}{\text{sample dry wt.}} = \frac{W_w}{W_s} \quad (2.11)$$

where  $W$  is the dry weight moisture fraction. To convert these soil moisture measurements into volumes of water, the volumetric moisture content must be computed:

$$\theta = \gamma_b W \quad (2.12)$$

where  $\gamma_b$  is the bulk specific weight of the dry soil. Also,  $\gamma_b$  is related to the specific weight of the soil particles,  $\gamma_s$ , by

$$\gamma_b = \gamma_s (1 - \phi) \quad (2.13)$$

Field capacity is defined as the moisture fraction,  $W_{fc}$ , of the soil when rapid drainage has essentially ceased and any further drainage occurs at a very slow rate. For a soil that has just been fully irrigated, rapid drainage has occurred after approximately 1 day for a "light" sandy soil and after approximately 3 days for a "heavy" soil. This corresponds to a soil moisture tension of 1/10 to 1/3 atm (bar).

The permanent wilting point,  $W_{wp}$ , is defined as the soil moisture fraction at which permanent wilting of the plant leaf has occurred and applying additional water will not relieve the wilted condition. This point is usually taken as the soil moisture content corresponding to a soil moisture tension of 15 bar.

The volumetric moisture contents at field capacity and permanent wilting point become

$$\theta_{fc} = \gamma_b W_{fc} \quad (2.14)$$

$$\theta_{wp} = \gamma_b W_{wp} \quad (2.15)$$

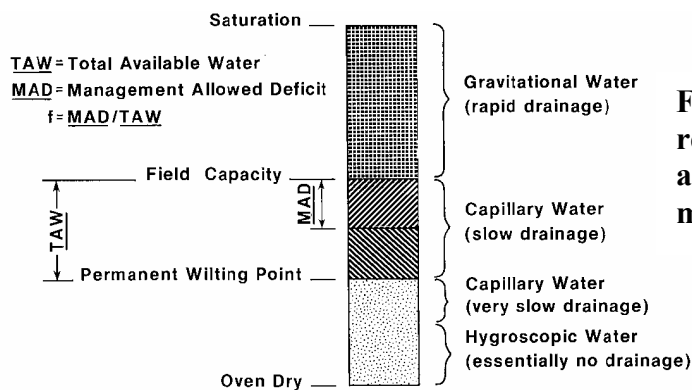
The total available water, TAW, to the plants is approximately the difference in these volumetric moisture contents multiplied by the depth of the root zone, RD:

$$TAW = (\theta_{fc} - \theta_{wp})RD \quad (2.16)$$

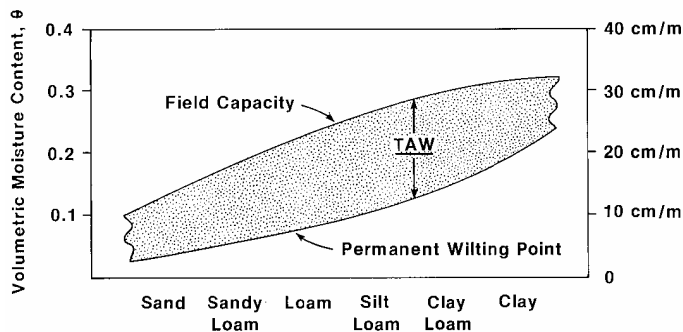
Equation 2.16 is not technically exact because crop roots do not extract water uniformly from the soil profile.

The relation between field capacity, permanent wilting point, and total available water is illustrated in Figs. 2.3 and 2.4. Table 2.1 lists some common rooting depths for selected crops.

The management allowed deficit, MAD, is the degree to which the volume of water in the soil is allowed to be depleted before the next irrigation is applied.




**Figure 2.3 Schematic representations of field capacity and permanent wilting point soil moisture content.**



**Figure 2.4 Representative values of total available water, TAW, for different soil types.**

**TABLE 2.1 AVERAGE ROOTING DEPTHS IN METERS OF SELECTED CROPS IN DEEP, WELL-DRAINED SOILS**

Alfalfa	1.5	Grapes	0.9
Almonds	2.0	Ladino clover and grass mix	0.6
Apricots	2.0	Lettuce	0.3
Artichokes	1.4	Melons	1.5
Asparagus	3.0	Milo	1.2
Barley	1.25	Mustard	1.1
Beans (dry)	1.1	Olives	1.5
Beans (green)	0.9	Onions	0.3
Beans (lima)	1.2	Parsnips	1.2
Beets (sugar)	0.8	Peaches	2.0
Beets (table)	0.9	Pears	2.0
Broccoli	0.6	Peas	0.8
Cabbage	0.6	Peppers	0.9
Cantaloupes	1.5	Potatoes (Irish)	0.9
Carrots	0.75	Potatoes (sweet)	1.3
Cauliflower	0.6	Prunes	1.7
Celery	0.6	Pumpkins	1.8
Chard	0.9	Radishes	0.5
Cherries	2.2	Spinach	0.6
Citrus	1.3	Squash (summer)	0.9
Corn (field)	1.2	Strawberries	0.2
Corn (sweet)	0.9	Sudan grass	1.5
Cotton	1.2	Tomatoes	1.0
Cucumber	1.1	Turnips	0.9
Eggplant	0.9	Walnuts	2.0
Figs	2.0	Watermelon	1.5
Grain and Flax	1.2		

 *Source:* After Doorenbos and Pruitt (1977) and Marr (1967).

MAD corresponds to a soil moisture content between field capacity and permanent wilting point, which is primarily dependent on type of crop and crop growth stage:

$$\text{MAD} = f \cdot \text{TAW} \quad (2.17)$$

The soil moisture deficit, SMD, is the depletion of soil moisture below field capacity at the time that a particular soil moisture content,  $\theta$ , is measured.

$$\text{SMD} = (\theta_{fc} - \theta) \text{RD} \quad (2.18)$$

## Infiltration

Infiltration is the most crucial factor affecting surface irrigation. This single parameter essentially controls not only the amount of water entering the soil, also the advance rate of the overland flow. Nor is any other factor as difficult to determine or predict with reliability and accuracy. Over the years, infiltration has been given a great deal of theoretical attention.

Historically, infiltration in borders and basins used the Kostiakov Equation:

$$Z = k\tau^a \quad (2.19)$$

where  $Z$  is the cumulative infiltration in  $m^3/m/m$ ,  $\tau$  is the “intake opportunity time” in minutes, and the  $k$  and  $a$  coefficients are empirical. The duration of the water application for these systems is usually short enough that the intake rate,  $I = \partial Z / \partial \tau$ , will not approach a zero value and thereby underestimate cumulative infiltration. In furrow irrigation systems, however this problem is nearly always encountered and researchers adopted the Kostiakov-Lewis Equation, which solves the long-term infiltration rate problem by adding a term for the final or “basic” intake rate:

$$Z = k\tau^a + f_o\tau \quad (2.20)$$

where  $f_o$  is the “basic intake rate” in  $m^3/m/m/min$ .

In recent studies, Eq. 2.20 has been expanded to include a combined term for both cracking and depression storage:

$$Z = k\tau^a + f_o\tau + c \quad (2.21)$$

where  $c$  is the amount of water applied to the soil through cracks or from depression storage following irrigation in  $m^3/m/m$ . One can observe that if  $f_o$  is set to zero, Eq. 2.21 has the same form as the NRCS infiltration equation (USDA, 1974), or:

$$Z = k\tau^a + c \quad (2.22)$$

Most design procedures in use today employ either Eq. 2.20 or Eq. 2.22. It is generally not necessary to have both a basic intake rate and a cracking/depression storage term simultaneously.

Several attempts have been made to describe the values of  $a$ ,  $k$ , and/or  $f_o$  as a function of soil type. Among the first of these was the US Department of Agriculture (1974), followed by an effort at Utah State University (Walker, 1989). Later Merriam and Clemmens (1985) visited the subject. In 1997, new sets of values were developed as part of the development of the **SIRMOD III** software to include both continuous and surge flow and for both first and later irrigations. Tables 2.2 – 2.4 present the **SIRMOD III** values of the Kostiakov-Lewis  $a$ ,  $k$ , and  $f_o$ -values for various basic soil types and as a function of the NRCS intake family number. There are no currently available recommendations for the  $c$ -value. However, some research is underway (McClymont and Smith, 1996).

**Table 2.2. Kostiakov-Lewis a-Values as Functions of NRCS Soil Intake Number for Continuous and Surged Flow, First and Later Irrigations.**

NRCS Curve No.	Soil Type	Continuous Flow, First Irrigations	Continuous Flow, Later Irrigations	Surged Flow, First Irrigations	Surged Flow, Later Irrigations
.01	Heavy Clay	.200	.200	.200	.200
.05	Clay	.258	.258	.258	.257
.10	Clay	.317	.316	.316	.316
.15	Light Clay	.257	.255	.256	.255
.20	Clay Loam	.388	.385	.386	.385
.25	Clay Loam	.415	.411	.412	.410
.30	Clay Loam	.437	.432	.434	.431
.35	Silty	.457	.451	.453	.450
.40	Silty	.474	.467	.469	.465
.45	Silty Loam	.490	.482	.484	.480
.50	Silty Loam	.504	.495	.498	.493
.60	Silty Loam	.529	.517	.521	.515
.70	Silty Loam	.550	.536	.540	.533
.80	Sandy Loam	.568	.551	.557	.548
.90	Sandy Loam	.584	.564	.571	.560
1.00	Sandy Loam	.598	.576	.583	.571
1.50	Sandy	.642	.606	.618	.599
2.00	Sandy	.672	.622	.638	.612
4.00	Sandy	.750	.638	.675	.615

**Table 2.3. Kostiakov-Lewis k-Values as Functions of NRCS Soil Intake Number for Continuous and Surged Flow, First and Later Irrigations.**

NRCS Curve No.	Soil Type	Continuous Flow, First Irrigations	Continuous Flow, Later Irrigations	Surged Flow, First Irrigations	Surged Flow, Later Irrigations
.01	Heavy Clay	.0044	.0044	.0044	.0044
.05	Clay	.0043	.0043	.0043	.0043
.10	Clay	.0038	.0038	.0038	.0038
.15	Light Clay	.0036	.0036	.0036	.0036
.20	Clay Loam	.0035	.0034	.0034	.0034
.25	Clay Loam	.0034	.0033	.0033	.0033
.30	Clay Loam	.0033	.0033	.0033	.0033
.35	Silty	.0033	.0033	.0032	.0032
.40	Silty	.0033	.0033	.0032	.0032
.45	Silty Loam	.0033	.0033	.0032	.0031
.50	Silty Loam	.0033	.0033	.0032	.0031
.60	Silty Loam	.0033	.0031	.0032	.0031
.70	Silty Loam	.0033	.0031	.0032	.0031
.80	Sandy Loam	.0033	.0031	.0032	.0031
.90	Sandy Loam	.0033	.0031	.0032	.0031
1.00	Sandy Loam	.0033	.0031	.0032	.0031
1.50	Sandy	.0034	.0032	.0033	.0032
2.00	Sandy	.0036	.0033	.0034	.0033
4.00	Sandy	.0042	.0038	.0036	.0034

Table 2.4. Kostiakov-Lewis  $f_0$ -Values as Functions of NRCS Soil Intake Number for Continuous and Surged Flow, First and Later Irrigations.

NRCS Curve No.	Soil Type	Continuous Flow, First Irrigations	Continuous Flow, Later Irrigations	Surged Flow, First Irrigations	Surged Flow, Later Irrigations
.01	Heavy Clay	.000011	.000011	.000011	.000011
.05	Clay	.000022	.000022	.000022	.000022
.10	Clay	.000035	.000035	.000035	.000035
.15	Light Clay	.000046	.000046	.000046	.000046
.20	Clay Loam	.000057	.000057	.000057	.000056
.25	Clay Loam	.000068	.000067	.000068	.000067
.30	Clay Loam	.000078	.000077	.000077	.000077
.35	Silty	.000088	.000087	.000087	.000087
.40	Silty	.000098	.000097	.000097	.000096
.45	Silty Loam	.000107	.000105	.000106	.000105
.50	Silty Loam	.000117	.000115	.000116	.000114
.60	Silty Loam	.000136	.000133	.000134	.000132
.70	Silty Loam	.000155	.000151	.000152	.000150
.80	Sandy Loam	.000174	.000119	.000171	.000168
.90	Sandy Loam	.000193	.000186	.000189	.000185
1.00	Sandy Loam	.000212	.000204	.000207	.000202
1.50	Sandy	.000280	.000264	.000270	.000261
2.00	Sandy	.000325	.000301	.000309	.000296
4.00	Sandy	.000390	.000332	.000351	.000320

Typical curves of infiltration rate,  $I$ , and cumulative infiltration,  $Z$ , are shown in Fig. 2.5. In an initially dry soil, the infiltration rate has a very high initial value, but rapidly decreases with time, until finally a fairly steady-state infiltration rate is reached. This steady-state infiltration rate is often referred to as the basic infiltration rate and is close to the value of the saturated hydraulic conductivity of the surface soil. Infiltration is a complex process dependent on soil properties, physical properties, initial soil moisture content, previous wetting history, permeability changes due to the surface water movement, and air entrapment. For surface-irrigated fields, the infiltration function changes dramatically for each irrigation event. A typical example of this variation is shown in Fig. 2.6. For any particular surface-irrigated field, the infiltration function is further dependent on cultivation practices, the type of crop being grown, and climatic effects (e.g., freezing and thawing action during the winter season).

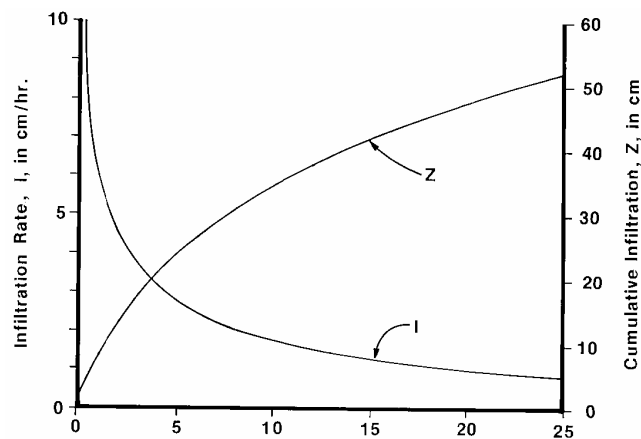
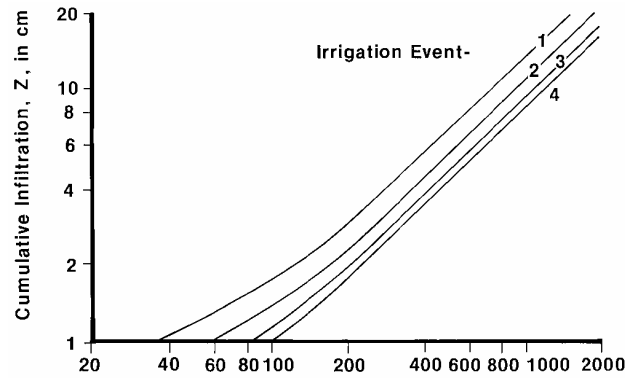


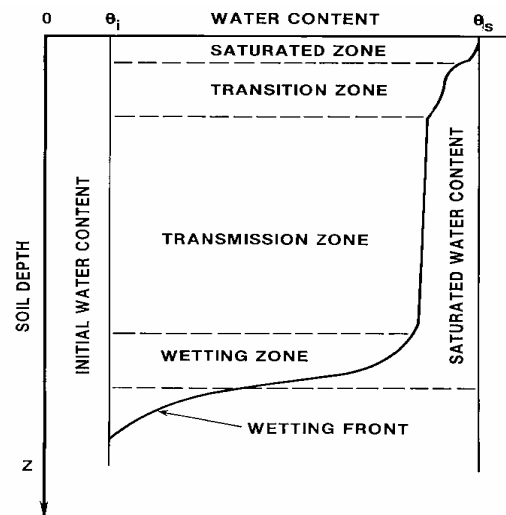
Figure 2.5 Example of infiltration rate,  $I$ , and cumulative infiltration,  $Z$ .



**Figure 2.6 Example of seasonal variation in cumulative infiltration,  $Z$ , by irrigation event.**

Bodman and Coleman (1943) described the moisture profile under ponded infiltration into dry soil as consisting of five general zones (see Fig. 2.7):

1. The saturated zone, which extends about 1.5 cm below the surface and has a saturated water content.
2. The transition zone, a region about 5 cm thick below the saturated zone where a rapid decrease in water content occurs
3. The transmission zone, where water content varies slowly with both depth and time
4. The wetting zone, in which there is a sharp reduction in water content
5. The wetting front, a region of very steep moisture gradients where the visible limit of moisture penetration into the soil column can be seen



**Figure 2.7. Soil-moisture profile during ponded infiltration. (Adapted from Bodman and Coleman, 1943, by permission of the Soil Science Society of America, Inc.)**

The transmission zone is particularly interesting because it has been found to have essentially constant hydraulic conductivity (Hansen, 1955) and a fairly uniform hydraulic

gradient (Miller and Richard, 1952). The water content in this zone is sometimes called "field saturation" and ranges between 0.8 and 0.9 (Slack, 1980).

The wetting front is a phenomenon unique to porous media flow. It is very sharp and can be easily observed in drier soils (Hanks and Ashcroft, 1976). The reason a sharp wetting front occurs is because the hydraulic conductivity (and consequently water diffusivity) of a soil changes drastically with water content.

### **Soil Physical Properties**

The soil matrix serves several very valuable functions, not the least of which is serving as a foundation to hold the plants upright. It must also furnish nutrients and provide a good balance between aeration and available moisture content.

Soil texture and structure influence the intermolecular forces and "suction" of water in unsaturated soils. These forces can be quite substantial and include the capillary and attractive forces resulting from the close contact of soil particles. Soil texture, primarily soil structure, greatly influences the porosity and distribution of pore sizes, and thereby the permeability of soils to air, water, and roots, which is as important to crop growth as an adequate supply of nutrients. In fact, the entire soil-water-plant system is so interrelated that the failure or lack of one component can cancel the combined benefits of all the others.

Irrigation practices are influenced by the degree of root proliferation since the water supply available to the plant is limited to the soil volume explored in the crop's root system. Different crops have different root growth patterns, hence different moisture extraction patterns. Obviously, a shallow-rooted crop will require more frequent irrigations than will a deep-wide-rooted crop in the same soil.

### **Soil Chemical Properties**

The chemical properties of soils can greatly influence how irrigable soils are by affecting the hydraulic characteristics and the suitability of the soil for crop production. Soils having an excess of soluble salts are designated as saline soils, and, if the soil has an excess of exchangeable sodium, it is termed a sodic soil. Sodic soils tend to have very poor soil structure, due to swelling or dispersion of soil particles. For example, the hydraulic conductivity of a soil can change as much as three orders of magnitude when the sodium adsorption ratio (SAR) is reduced from a value of 20 to a value of 1.

Excess soil salinity will delay or prevent crop germination and can substantially reduce the amount and rate of plant growth because of the high osmotic pressures which develop between the soil-water solution and the plant. These pressures, which appear to be independent of the type of salts present, greatly impair the plant's ability to absorb water. In addition, some adverse effects due to salinity can include nutritional imbalances or toxicities caused by specific ions (e.g., boron, which is toxic in very small quantities). In sufficient concentrations, even beneficial salts (fertilizers such as potassium nitrate) can become toxic to plants.

In addition to the soil chemical characteristics mentioned above, the soil must also have an adequate supply of available plant nutrients. Many chemical elements are essential for plant growth and are necessary to obtain large and satisfactory crop yields. These include calcium, carbon, hydrogen, iron, magnesium, nitrogen, oxygen, potassium, phosphorus, sulfur, and many

other trace elements, depending on the type of crop. The availability of these nutrients to the plant depends to a large extent upon the moisture content of the soil.

Bacterial activity is also an important part of the soil-water-plant relationship because this action will often convert nitrogen to a usable form (nitrogen-fixing). Bacterial action also breaks down organic matter and converts other chemical compounds into forms usable by the plants. Soil moisture content, soil structure, and soil aeration directly influence bacterial activity.

## ***CROP EVAPORATIVE AND DRAINAGE REQUIREMENTS***

### **Evapotranspiration**

An important parameter in the water balance equation is the evapotranspiration from the crop and soil surface,  $D_{et}$ . It is dependent on climatic conditions, crop variety and stage of growth, soil moisture depletion, and various physical and chemical properties of the soil. A two-step procedure is generally followed in estimating  $D_{et}$ : (1) computation of the seasonal distribution of "potential evapotranspiration,"  $E_{tp}$ ; and (2) adjustment of  $E_{tp}$  for crop variety and stage of growth. Most of the other factors playing a role, such as soil moisture stress, are ignored for the purposes of design computations. Thus the values of  $D_{et}$  are larger than what might be normally encountered, thereby adding a conservative factor to the design process.

There are more than 20 commonly used methods for calculating evapotranspiration, ranging in sophistication from simple temperature correlations, such as the Blaney-Criddle method, to complete equations describing radiant and advective energy balance, such as the Penman method and its derivatives (Allen et al., 1998; Jensen, et al., 1990). Two computer-based tools that are now available are the **REF-ET** (Allen, 2001), which provides reference ET calculations for FAO and ASCE standardized equations, and the **CROPWAT** program (Smith, 1992).

The REF-ET program is available from the University of Idaho. The costs and purchase procedures can be found at: <http://www.kimberly.uidaho.edu/ref-et/>. The CROPWAT program is available through the FAO and can be downloaded at no cost at the following internet address: <http://www.fao.org/WAICENT/FaoInfo/Agricult/aql/lwris.HTM>.

### **Drainage Requirement**

The minimum amount of required subsurface drainage water (deep percolation) is usually calculated on the basis of removing as much salt as is applied to the cropland by irrigation. Although measuring total dissolved solids (TDS) in the irrigation water is a more accurate measure of the salt concentration in these waters, more frequently the electrical conductivity (EC) is measured because of ease in making either field or laboratory measurements. Maintaining a salt balance in the root zone then requires that

$$D_{dr} EC_{dp} = D_z EC_z \quad (2.23)$$

where  $D_{dr}$  = depth of required subsurface drainage  
 $EC_{dp}$  = electrical conductivity of deep percolating water  
 $D_z$  = depth of infiltrated water resulting from the irrigation water supply  
 $EC_z$  = electrical conductivity of the irrigation water supply

The U.S. Salinity Laboratory (1954) defines the leaching requirement, LR, as

$$LR = \frac{D_{dr}}{D_z} = \frac{EC_z}{EC_{dp}} \quad (2.24)$$

Referring to the water balance schematic in Fig. 2.1, the root zone water balance (Eq. 2.6) can be written as a function of the leaching requirement by substituting  $D_{zr}$  for  $D_{dp}$ . Ignoring the contribution from groundwater and plant canopy interception, and utilizing Eq. 2.23, the required infiltrated depth of irrigation water to satisfy the leaching requirement is

$$D_{zr} = (D_{\Delta s} + D_{et} - D_{pz}) \frac{EC_{dp}}{EC_{dp} - EC_z} \quad (2.25)$$

This required depth of infiltrated irrigation water does not have to be achieved during each irrigation event. Quite frequently, Eq. 2.25 would be applied on an annual basis, thereby taking into account the large deep percolation losses that usually occur with the first (and second) irrigation events of the season, as well as the benefits from precipitation (and snowmelt) events throughout the year. In some irrigated areas, maintaining a salt balance in the root zone is achieved during years of plentiful water supplies, which may be as long as every 3 to 8 years.

## ***IRRIGATION EFFICIENCY AND UNIFORMITY***

### **General Discussion**

The objective of providing a suitable level of moisture in the soil for plant growth can be achieved by any irrigation system by simply over watering. The performance of the system is optimized when the moisture level "suitability" is maintained, but the evaporative, runoff, and percolation losses are minimized. To index the performance of the irrigation system, irrigation uniformity and efficiency are defined. However, since an irrigation system is composed of different parts and utilized in different ways, there are a large number of individual expressions for uniformity and efficiency.

Because of the uncertainty associated with the soil infiltration characteristics, the performance of surface irrigation systems is not predictable without assessing the individual system. Even when a level of performance is dictated by design practices, there is no assurance that the field system will perform as intended. In Chapter 4 field evaluation procedures and the interpretation of their data are described.

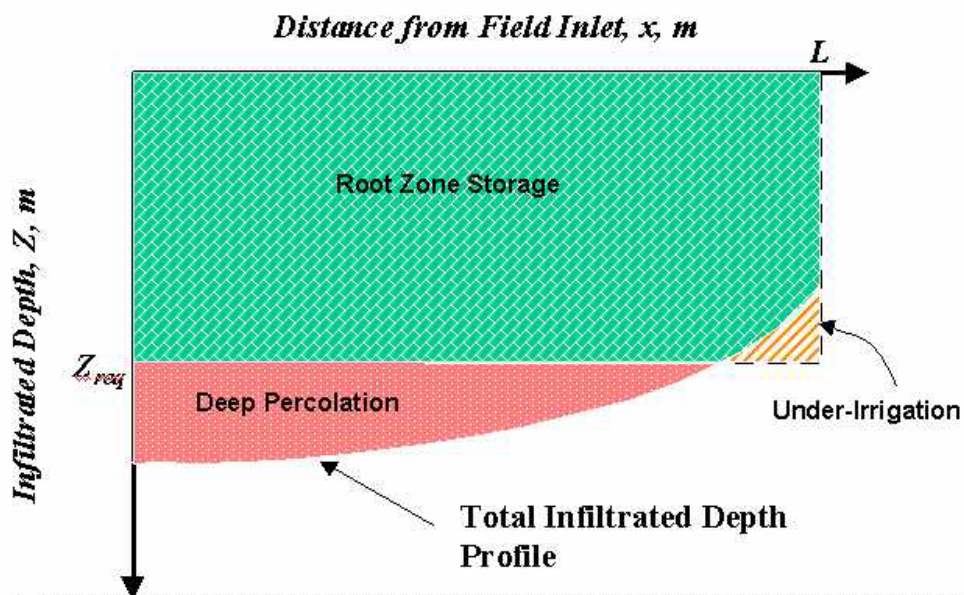
### **Application Uniformity and Efficiency**

Among the factors used to judge the performance of an irrigation system or its management, the most common are efficiency and uniformity. These parameters have been subdivided and defined in a multitude of ways. There is no single parameter that adequately defines irrigation performance. Conceptually, the adequacy of irrigation depends on how much water is stored within the crop root zone, losses percolating below the root zone, losses occurring as surface runoff or tailwater, the uniformity of the applied water, and the remaining deficit or

under-irrigation within the soil profile following irrigation. Ultimately, the measure of performance is whether or not the system optimizes production and profitability on the farm. In order to index these factors in the surface irrigated environment, the following assumptions are made:

1. The crop root system extracts moisture from the soil uniformly with respect to depth and location;
2. The infiltration function for the soil is a unique relationship between infiltrated depth and the time water is in contact with the soil (intake opportunity time); and
3. The objective of irrigating is to completely refill the root zone.

When a field with a uniform slope, soil and crop receives steady flow at its upper end, a water front will advance at a monotonically decreasing rate until it reaches the end of the field. If it is not diked, runoff will occur for a time before recession starts following shutoff of inflow. Figure 2.8 shows the distribution of applied water along the field length stemming from the assumptions listed above. The differences in intake opportunity time produce applied depths that are non-uniformly distributed with a characteristic shape skewed toward the inlet end of the field.



**Figure 2.8. Components of infiltrated water under surface irrigation.**

The amount of water that can be stored in the root zone is  $LZ_{req}$ , but as shown, some region of the root zone has not received water owing to the spatial distribution of infiltration. The depth of water that would refill the root zone is  $Z_{req}$ , beyond which water percolates below the roots and is “lost”<sup>3</sup> to the drainage or groundwater system. Computing each of these components requires a numerical integration of infiltrated depth over the field length. For the purposes of this discussion, it is convenient to define the components as follows:

<sup>3</sup> Generally these flows return to receiving waters where they can be used elsewhere. Thus, they are lost in terms of the local condition but perhaps not to the regional or basin locale. The negative connotations of loss should be kept even though this water may be recovered and reused. The quality of these flows is nearly always degraded and the timing of when they are available elsewhere may not be useful.

$V_{rz}$  is the volume of water per unit width or per furrow spacing that is actually stored in the root zone.

$V_{di}$  is the volume of water per unit width or per furrow spacing that is represented as the under-irrigation.

$V_{dp}$  is the volume of water per unit width or per furrow spacing that percolates below the root zone.

$V_{tw}$  is the volume of water per unit width or per furrow spacing that flows from the field as tailwater.

$Z_{min}$  is the minimum depth of infiltration applied to the field, often but not always located at the downstream end of the field.

$Z_{lq}$  is the average depth of infiltrated water in the least-irrigated 25% of the field.

Application uniformity concerns the distribution of water over the actual field. Merriam and Keller (1978) propose that distribution uniformity be defined as the average infiltrated depth in the low quarter of the field divided by the average infiltrated depth over the whole field. This term can be represented by the symbol,  $DU$ . The same authors also suggest an 'absolute distribution uniformity',  $DU_a$  which is the minimum depth divided by the average depth. Thus:

$$DU = \frac{Z_{lq}}{\frac{V_{rz} + V_{dp}}{L}} \quad (2.26)$$

and

$$DU_a = \frac{Z_{min}}{\frac{V_{rz} + V_{dp}}{L}} \quad (2.27)$$

The definition of application efficiency,  $E_a$ , has been fairly well standardized as:

$$E_a = \frac{V_{rz}}{V_{rz} + V_{dp} + V_{tw}} \quad (2.28)$$

Losses from the field occur as deep percolation (depths greater than  $Z_{req}$ ) and as field tailwater or runoff. To compute  $E_a$ , it is necessary to identify at least one of these losses as well as the amount of water stored in the root zone. This implies that the difference between the total amount of root zone storage capacity available at the time of irrigation and the actual water stored due to irrigation be separated, i.e. the amount of under-irrigation in the soil profile must be determined as well as the losses.

The water requirement efficiency,  $E_r$ , which is also commonly referred to as the storage efficiency is defined as:

$$E_r = \frac{V_{rz}}{V_{rz} + V_{di}} \quad (2.29)$$

The requirement efficiency is an indicator of how well the irrigation meets its objective of refilling the root zone. The value of  $E_r$  is important when either the irrigations tend to leave major portions of the field under-irrigated or where under-irrigation is purposely practiced to use precipitation as it occurs. This parameter is the most directly related to the crop yield since it will reflect the degree of soil moisture stress. Usually, under-irrigation in high probability rainfall areas is a good practice to conserve water but the degree of under-irrigation is a difficult question to answer at the farm level.

To improve the performance of a surface irrigation system, the measures of uniformity and efficiency may need to be more qualitative. DU gives minimal information about the magnitudes of losses or under-irrigation.  $E_a$  does not allow the engineer to segregate deep percolation losses from tailwater losses and it is difficult to assess the degree of under-irrigation. Since these items are important, two additional indicators are proposed: (1) deep percolation ratio, DPR; and (2) tailwater ratio, TWR. They are defined as follows:

$$\text{DPR} = \frac{\text{average depth of deep percolation}}{\text{average depth applied}} \quad (2.30)$$

$$\text{TWR} = \frac{\text{average depth of field runoff}}{\text{average depth applied}} \quad (2.31)$$

### ***IRRIGATION REQUIREMENT***

It can be observed from the preceding discussion that if the irrigation system could be operated with an application efficiency and water requirement efficiency of 100% (implying that  $DU = 1.0$ ), the irrigation requirement would be the sum of the crop water requirement and the leaching requirement. Because this is impractical, the irrigation requirement is often defined as:

$$\text{IR} = \frac{D_{et} - (D_p - D_{pr})}{E_a} \quad (2.32)$$

where IR is the irrigation requirement and  $E_a$  is expressed as a fraction. It is implicitly assumed in Eq. 2.32 that  $E_r$  is generally 100%, so that the natural inefficiency of the system is sufficient to leach salts from the least-watered area. Where soils are relatively well drained, the writers have not observed soil salinization due to under-irrigation.

### **REFERENCES**

- Allen, R. G. 2001. REF-ET: Reference Evapotranspiration Calculation Software for FAO and ASCE Standardized Equations. Version 2.0 for Windows. University of Idaho, Moscow, Idaho. 76p.
- Allen, R. G., L. S. Pereira, D. Raes, and M. Smith. 1998. Crop Evapotranspiration: Guidelines for Computing Crop Water Requirements. UN-FAO Irrigation and Drainage Paper 56. Rome, Italy. 300p.
- Beggs, R. A. 1981. A portable Field Sprinkling Infiltrometer. Unpublished M.S. thesis, Agricultural and Irrigation Engineering Department, Utah State University, Logan, Utah.
- Bodman, G. B., and E. A. Coleman. 1943. Moisture and Energy Conditions during Downward Entry of Water into Soils. Soil Sci. Soc. Am. Proc. 8:116-122.

- Doorenbos, J., and W. O. Pruitt. 1977. *Crop Water Requirements (Revised Edition)*. FAO Irrig. Drain. Pap. 24. United Nations, Food and Agriculture Organization, Rome.
- Hanks, R. J., and G. L. Ashcroft. 1976. *Physical Properties of Soils*. Department of Soil Science and Biometeorology, Utah State University Press, Logan, Utah, Chap. 6.
- Hansen, V. 1955. Infiltration and Soil Water Movement during Irrigation. *Soil Sci.* 79:93-104.
- Jensen, M. E., R. D. Burman and R. G. Allen (ed). 1990. *Evapotranspiration and Irrigation Water Requirements*. ASCE Engineering Practice Manual No. 70. American Society of Civil Engineers, New York.
- Kostiakov, A. V. 1932. On the dynamics of the coefficient of water-percolation in soils and on the necessity for studying it from a dynamics point of view for purposes of amelioration. *Trans. Sixth Comm. Int. Soc. Soil Sci.*, Part A, pp. 17-21.
- Marr, J. C. 1967. *Furrow Irrigation. Manual 37*. California Agricultural Experiment Station, University of California, Davis.
- McClymont D. J. and R. J. Smith. 1996. *A Infiltration Parameters from Optimization on Furrow Irrigation Advance Data*.@ Irrigation Science, ():- -.
- Merriam, J. L., and J. Keller. 1978. *Farm Irrigation System Evaluation: A Guide for Management*. Department of Agricultural and Irrigation Engineering, Utah State University, **Logan, Utah**.
- Merriam, J.L. and Clemmens, A.J. 1985. Time rated infiltrated depth families. p. 67-74 in *Development and Management Aspects of Irrigation and Drainage*, Spec. Conf. Proc., Irrig. and Drain. Div., ASCE, San Antonio, TX, July.
- Miller, R. D., and F. Richard. 1952. Hydraulic Gradients during Infiltration in Soils. *Soil Sci. Soc. Am. Proc.* 16:33-38.
- Slack, D. C. 1980. Modeling Infiltration under Moving Sprinkler Irrigation Systems. *Trans. Am. Soc. Agric. Eng.* 23:596-600.
- US Department of Agriculture, Natural Resource and Conservation Service. *National Engineering Handbook*, 1974. Section 15, Chapter 4, *Border Irrigation*. US Government Printing Office, Washington, DC.
- U.S. Salinity Laboratory. 1954. *Diagnosis and Improvement of Saline and Alkali Soils*. Agric. Handb. 60. U.S. Department of Agriculture, Riverside, Calif.
- Walker, W. R. 1979. Explicit Sprinkler Irrigation Uniformity: Efficiency Model. *ASCE J. Irrig. Drain. Div.* 105(IR2):129-136.
- Walker, W. R. 1989. *Guidelines for designing and evaluating surface irrigation systems*. FAO Irrigation and Drainage Paper 45, Food and Agriculture Organization of the United Nations, Rome, Italy. 137p.
- Walker, Wynn R. and Gaylord V. Skogerboe. 1987. ***Surface Irrigation: Theory and Practice***. Prentice-Hall Inc., Englewood Cliffs, NJ. 386pp.

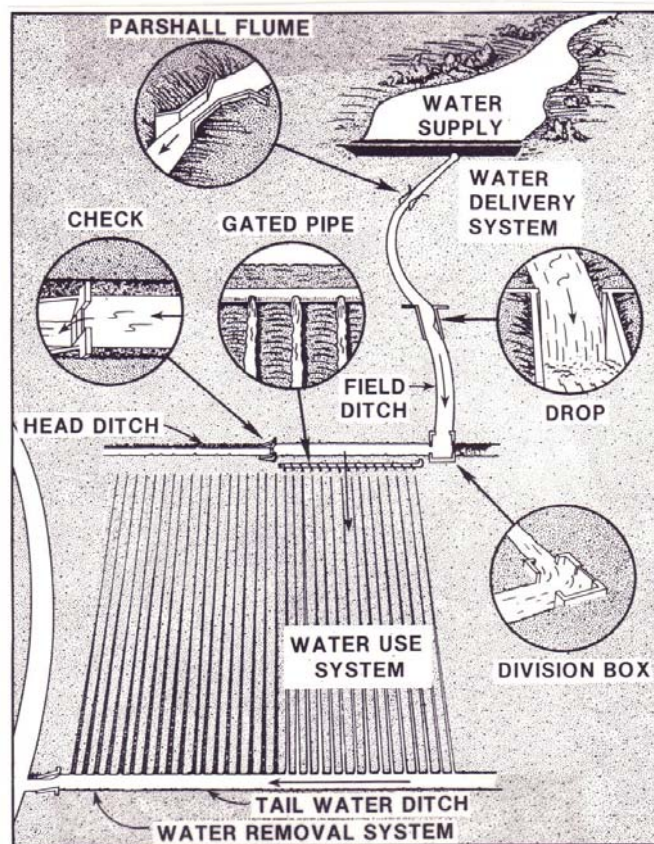
---

## Chapter 3. Surface Irrigation Systems<sup>4</sup>

---

### INTRODUCTION

As the oldest and most common method of applying water to croplands, surface irrigation has evolved into an extensive array of configurations. Efforts to classify surface systems differ substantially, but generally include the following: (1) basin irrigation, (2) border irrigation, (3) furrow irrigation, and (4) wild flooding. The distinction between the various types involves substantial overlap and no clear-cut definition of terminology exists. The discussion in this chapter represents the classification used by the writers and is given for illustrative purposes.



 **Figure 3.1 Typical elements of a surface irrigation system. (From U.S. Department of Agriculture, Soil Conservation Service, 1967.)**

The irrigation system as a whole consists of four subsystems, as illustrated in Fig. 3.1. These are: (1) the water supply subsystem, (2) the water delivery subsystem, (3) the water use subsystem, and (4) the water removal subsystem. There are many alternative configurations within each subsystem. For example, the water supply subsystem can also include direct

---

<sup>4</sup> Taken from Walker and Skogerboe (1987), and Walker (1989).

diversions from rivers or streams or pumped flows from groundwater basins in addition the diversions from surface impoundments as shown.

The scope of surface irrigation study in this book is limited to the water-use system. It includes the headland facilities (head ditches, etc.), the method of water application to the field (basin, border, furrow, wild flooding, etc.), and facilities to collect and convey surface drainage (tailwater or field runoff). It should be noted and carefully noted that the optimal irrigation system in a region can only be realized when each subsystem is properly integrated and managed collectively.

### ***TYPES OF SURFACE SYSTEMS***

Each surface system has its own unique advantages and disadvantages depending on such factors as (1) initial development costs, (2) size and shape of individual fields, (3) soil characteristics, (4) nature and availability of the water supply, (5) climate, (6) cropping pattern, (7) social preferences and structures, and (8) historical experience. For the most part, the most often used characteristics to distinguish surface irrigation systems are physical features of the irrigated fields.

#### **Basin Irrigation**

Historically, basin irrigation has been the irrigation of small irregular or square areas having completely level surfaces and enclosed by dikes to prevent runoff. Two typical examples are shown in Fig. 3.2. To segregate basins from level borders (discussed in the next section), the basin terminology will be applied primarily to level areas having complete perimeter dikes to prevent runoff. Figure 3.2a illustrates the most common basin irrigation concept. Water is added to the basin through a gap in the perimeter dike or adjacent ditch. It is important for the water to cover the basin quickly and be shut off when the correct volume has been supplied.

If the basins are small or if the discharge rate available is relatively large, there are few soils not amenable to basin irrigation. Generally, basin irrigation is favored by moderate to slow intake soils and deep-rooted, closely spaced crops. Crops which do not tolerate flooding and soils subject to crusting: can be basin irrigated by furrowing or using raised bed planting. Basin irrigation is an effective method of leaching salts from the soil profile. Basin irrigation systems can be automated with relatively simple and inexpensive flow controls at the basin inlet.

Basin irrigation has a number of limitations that are recognized primarily in association with agriculture in the less developed countries. Accurate land leveling is prerequisite to high uniformities and efficiencies, but this is difficult to accomplish in small areas. The perimeter dikes must be well maintained to eliminate breaching and waste. It is difficult and often infeasible to incorporate the use of modern farm machinery in small basins, thereby limiting small-scale basin irrigation to hand and animal powered cultivation.



(a)

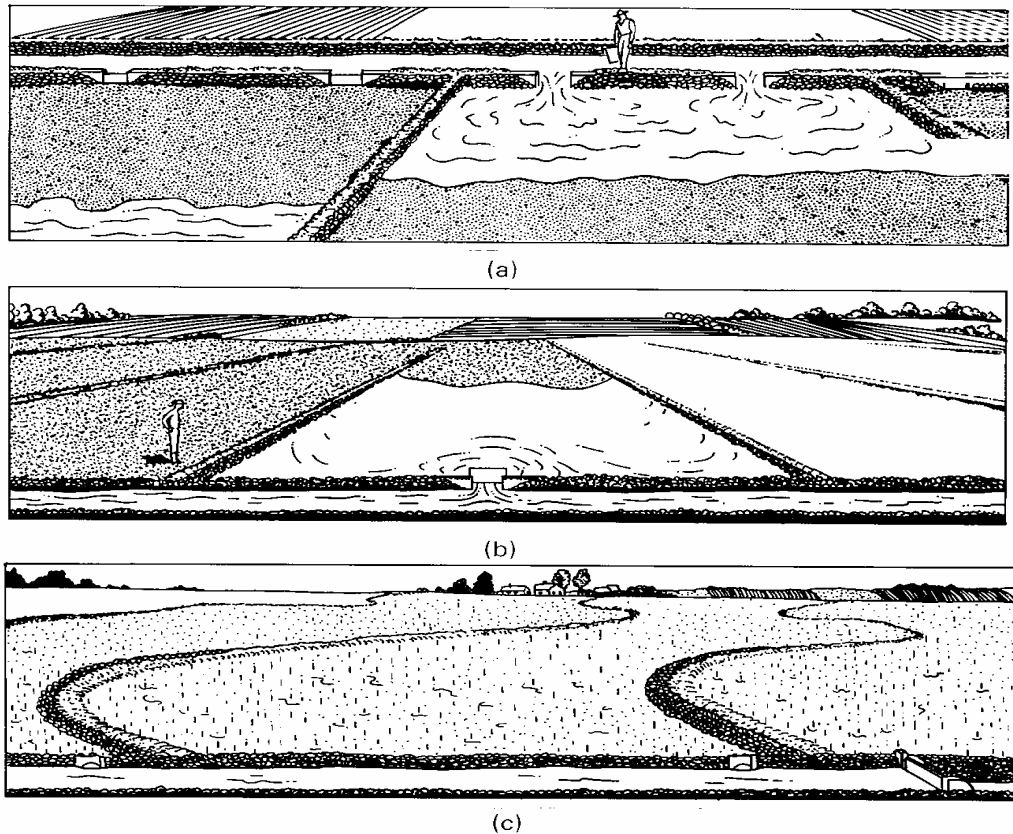


(b)

**Figure 3.2 Typical basin irrigation systems.. (Fig. 3.2a courtesy of Dr. Gary P. Merkley)**

### **Border Irrigation**

In many circumstances, border irrigation can be viewed as an expansion of basin irrigation to include long rectangular or contoured field shapes, longitudinal but no lateral slope, and free draining or blocked conditions at the lower end. Figure 3.3 illustrates three typical border irrigation systems.



**Figure 3.3 Examples of border irrigation systems. (a) Typical graded border irrigation system. (b) Typical level border irrigation system. (c) Typical contour levee or border irrigation system. (Source: U.S. Department of Agriculture, Soil Conservation Service, 1967.)**

Figure 3.3a shows a field divided into graded borders. Water is applied to individual borders from the field head ditch and utilizes the elevation differences to traverse the field. When the water is shut off, it recedes from the upper end to the lower end. Graded borders are suited for nearly any crop except those that require prolonged flooding. Soils can have moderately low to moderately high intake rates, but should not crust easily unless the borders are furrowed or the crops are grown on raised beds. The stream size per unit width must be large, particularly following a major tillage operation, in order to achieve rapid field coverage. As with basins, field topography is critical, but the extended areas permit better leveling through the use of farm machinery. Initial land leveling costs may be prohibitive unless the general terrain is relatively flat.

Figure 3.3b and c indicate conditions where the borders are level and water ponds evenly over the soil surface. Level borders or long basins are usually diked at the ends to prevent runoff and thereby achieve high uniformities and efficiencies. Leveling has been a traditional problem, but with the advent of laser technology, level basins and borders have enjoyed an increasing popularity. The limitations are essentially the same as with other forms of basin or border irrigation.

## **Furrow Irrigation**

An alternative to flooding the entire field surface is to construct small channels along the primary direction of water movement. Water introduced in these "furrows," "creases," or "corrugations" infiltrates through the wetted perimeter and moves vertically and laterally thereafter to refill the soil. Furrows can be used in conjunction with basins and borders, as noted earlier, to overcome topographical variation and crusting. When individual furrows are supplied water as opposed to field spreading prior to the furrows, the method will be called furrow irrigation.

Furrows provide better on-farm water management capabilities under most surface irrigation conditions. Flow rates per unit width can be substantially reduced and topographical conditions can be more severe and variable. A smaller wetted area can reduce evaporative losses on widely spaced crops. Furrows provide operational flexibility important for achieving high efficiencies for each irrigation throughout a season. It is a simple (although labor intensive) matter to adjust the furrow stream size to changing intake characteristics by simply changing the number of simultaneously supplied furrows.

The disadvantage of furrows include (1) potential salinity hazards between furrows, (2) greater likelihood of tailwater losses unless end dikes are used, (3) limited machinery mobility across the lateral field direction, (4) the need for one extra tillage practice (furrow construction), and (5) an increased erosion potential. Furrow systems require more labor than border and basin systems and are occasionally more difficult to automate. Figure 3.4 shows three typical furrow-irrigated conditions.

## ***WATER SUPPLY AND MANAGEMENT***

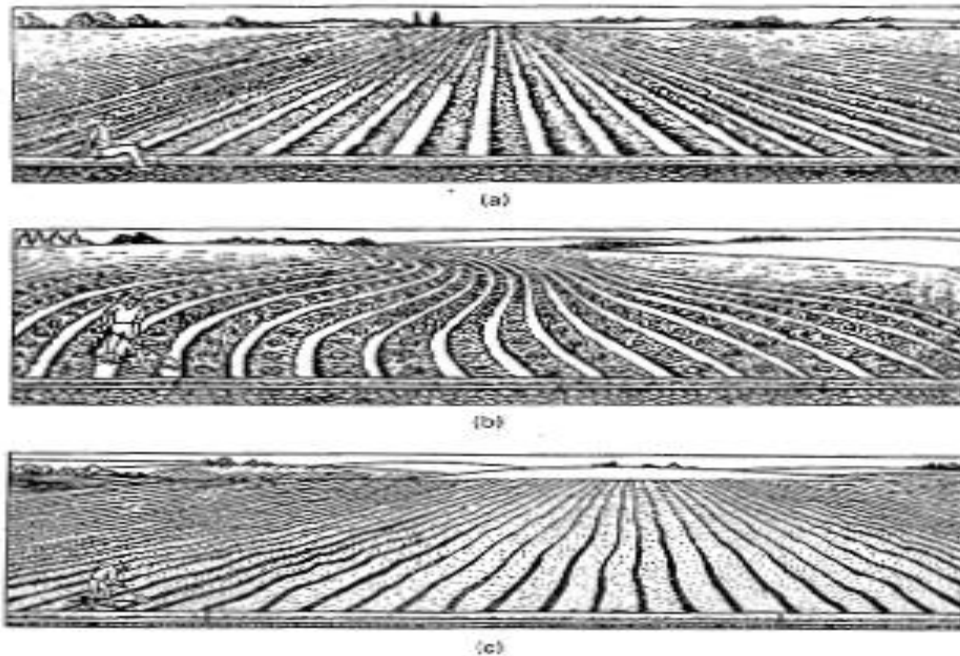
Even though it is the oldest and most common method of irrigation, surface irrigation is the least amenable to consistently high levels of performance. Of all the reasons why this is so, probably none have the significance that is associated with the uncertainty of soil infiltration rates. The rate at which water will be absorbed through the soil surface is a nonlinear process which varies both temporally and spatially. It is affected by year-to-year changes in cropping patterns, cultivation, the weathering due to climate, and many other unknown influences. As a result, neither the irrigator nor the engineer can accurately predict the uniformity and efficiency of an irrigation before it occurs, particularly the first water application following planting.

There are other factors limiting surface irrigation system performance, such as a relative lack of standardized equipment for regulation and automation. These and the intake variability noted above place particular emphasis on the management practices applied to surface irrigation, and the art of surface irrigation management is very important. These practices can be classified according to (1) regulation of the field inlet discharge, (2) amending the field surface, and (3) water recovery and reuse.

### **Inlet Discharge Control Practices**

In order to achieve uniform water application, the advancing waterfront should cover the field during a short interval, certainly not longer than required to infiltrate a depth equal to the soil moisture depletion. A quarter-time rule of thumb was first proposed in published form by Criddle et al. (1956) in which the advance time should be equal to one-fourth of the necessary intake opportunity time. The rule is generally more applicable to sloping fields than to level

ones and may be unnecessary if soil infiltration rates reach a steady state value very rapidly. The increasing popularity of level basins and borders, which has been facilitated by laser-controlled land-leveling equipment, has shifted the desired advance interval somewhat. Under these conditions, advance is shortened as much as possible.



**Figure 3.4. Examples of furrow irrigation systems. (a) Graded or level-furrow irrigation system. (b) Contour furrow irrigation system. (c) Corrugated form of a furrow irrigation system. (After U.S. Department of Agriculture, Soil Conservation Service, 1967.)**

Although rapid advance is recommended, it imposes the problem of large tailwater volumes unless the downstream end of the field is blocked. Irrigators can minimize these problems when the downstream end is not blocked by reducing the inlet discharge by roughly one-half when the flow reaches the end of the field. This practice is called "cutback" irrigation.

One of the problems in surface irrigation is that the first irrigation of the season following planting often requires two or three times the flow rate that subsequent irrigations need to achieve acceptable uniformity. The infiltration rates are higher during the initial irrigations and thus the need for higher inlet flows. As the soil intake diminishes during the season, the inlet flows can be reduced. Thus, the design and operation of surface irrigation systems requires adjusting the inlet flow to achieve maximum efficiencies.

### **Field Surface Amendments**

Surface irrigation performance can be improved by accurate leveling and smoothing the field surface. Where the grade is irregular, causing dry spots and excessive depression storage, land leveling is an important practice. One of the most important innovations for surface irrigation has been the laser guided land leveling equipment as shown in Fig. 3.5.



**Fig. 3.5. Laser Guided Land Leveling Equipment.**

Furrowing borders or basins also reduces the effect of topographical variations. Some soils are too coarse textured for efficient surface irrigation, but practices aimed at incorporating crop residues and animal manures not only reduce intake rates but also improve soil moisture-holding capacity. When water advance over a freshly cultivated field is a problem due to high intake, a limited discharge, or an erosion problem, the surface is often smoothed and compacted by attachments to the planting machinery.

A major cause of inefficiency in furrowed or corrugated surface systems occurs when crops are planted in rows halfway between furrows. The water must move horizontally to the seed location, which requires water-soil contact times much larger than the opportunity time needed to refill the root zone. These types of problems can be corrected by altering planting and cultivation practices, such as planting nearer the furrow, or planting double rows between furrows.

### **Wastewater Recovery and Reuse**

Tailwater storage and recycling are methods that improve surface irrigation practices. Today, it is often more economical to cut back the flow rather than pump the unused portion back to the head of the field. Nevertheless, tailwater systems are very cost-effective when the water can be added to the flow serving lower fields. Two views of a typical tailwater recovery system are shown in Fig. 3.6.



**Fig. 3.6. Two views of typical tailwater recovery and reuse facilities.**

In order to convey water over the field surface rapidly enough to achieve a high degree of application uniformity and efficiency, the discharge at the field inlet must be much larger than the cumulative intake along the direction of advance. As a result, there remains a significant fraction of the inlet flow at the end of the field which will be wasted unless the field is diked or the tailwater is captured and reused. In many locations, the reason to capture tailwater is not so much for the value of the water but for the soil it has eroded from the field surface. Other conditions exist where erosion is not a problem and the water supply is abundant, so the major emphasis is merely to remove the tailwater before waterlogging and salinity problems emerge. Finally, it may be cost-effective to impound the tailwater and pump it back to the field inlet for reuse or store it for use on lower-lying fields.

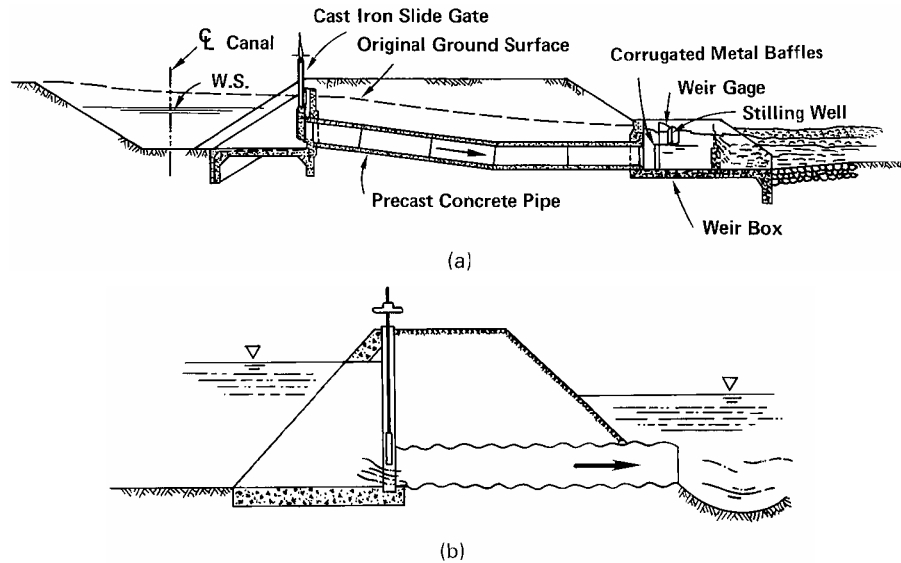
### ***STRUCTURAL ELEMENTS***

Surface irrigation systems involve a number of structural elements which control the rate of flow and its energy. To achieve efficient use of the water on the field, these elements should provide a steady, reliable discharge and be capable of effective operation under a number of adverse conditions. The individual elements should be standardized to allow mass production or fabrication.

The elements of a surface irrigation system serve several functions and are generally arranged in the following order: (1) on-off flow control, (2) conveyance, (3) water management, (4) field distribution, and (5) tailwater removal or reuse. To gain a general perception of these structural elements, a brief discussion is included here to illustrate their function.

### **Diversion Structures**

Most surface irrigation systems at the farm level are supplied water from open canal systems operated by irrigation districts, companies, or corporations. Variations include piped delivery systems and groundwater supplies. Diversion structures often perform several tasks. First, they provide on-off water control, which not only allows the supplier to allocate its water supply, but also protects the fields below the diversion from untimely flooding. Second, diversion structures regulate and stabilize the discharge to the requirements of field conveyance and distribution systems. Flow measurement is usually incorporated at the turnout in order to establish and protect the basic water entitlement. Finally, many diversion structures serve as further protection to downstream structures by controlling sediments and debris as well as dissipating excess kinetic energy in the flow. Two typical canal turnout diversion structures are shown in Fig. 3.7.



**Figure 3.7 Typical canal turnout structure. (a) Pipe turnout into a concrete pipe with downstream flow measurement and energy dissipation. (b) Pipe turnout into a corrugated pipe section. (Skogerboe et al., 1971.)**

### Conveyance and Management Structures

The delivery of water from the canal turnout to the field inlet requires the same (although smaller) conveyance and control structures found in major canal networks. The conveyance itself is usually an earthen ditch or lateral, a buried pipe, or a lined ditch. Pipe materials are usually plastic (PVC), concrete, clay, or asbestos cement, but may be as simple as a wooden square or rectangular construction. Open-channel linings include slip-form or prefabricated concrete, shotcrete or gunite, asphalt, masonry, surface and buried plastic or rubber membranes, and compacted earth.

The control of water within the conveyance system involves flow measurement, sediment and debris removal, divisions, checks, drops, energy dissipators, and water-level controls. A few of the more common flow-measuring structures for open channels are shown in Fig. 3.8. These include various weirs, flumes, and orifices. An array of checks, drops, dividers, and water-level controllers are shown in Fig. 3.9. The design of these structures is often simple since they are small. The most critical designs are for flow measurement and drop energy dissipator structures.

### Field Distribution Systems

When the water arrives at the field, it must be transferred and spread across the field within fairly precise limits. Usually, each field has a head ditch or pipeline running along the upper side of the field. From there the flow is distributed onto the field by a multitude of methods, a few of which will be mentioned here.

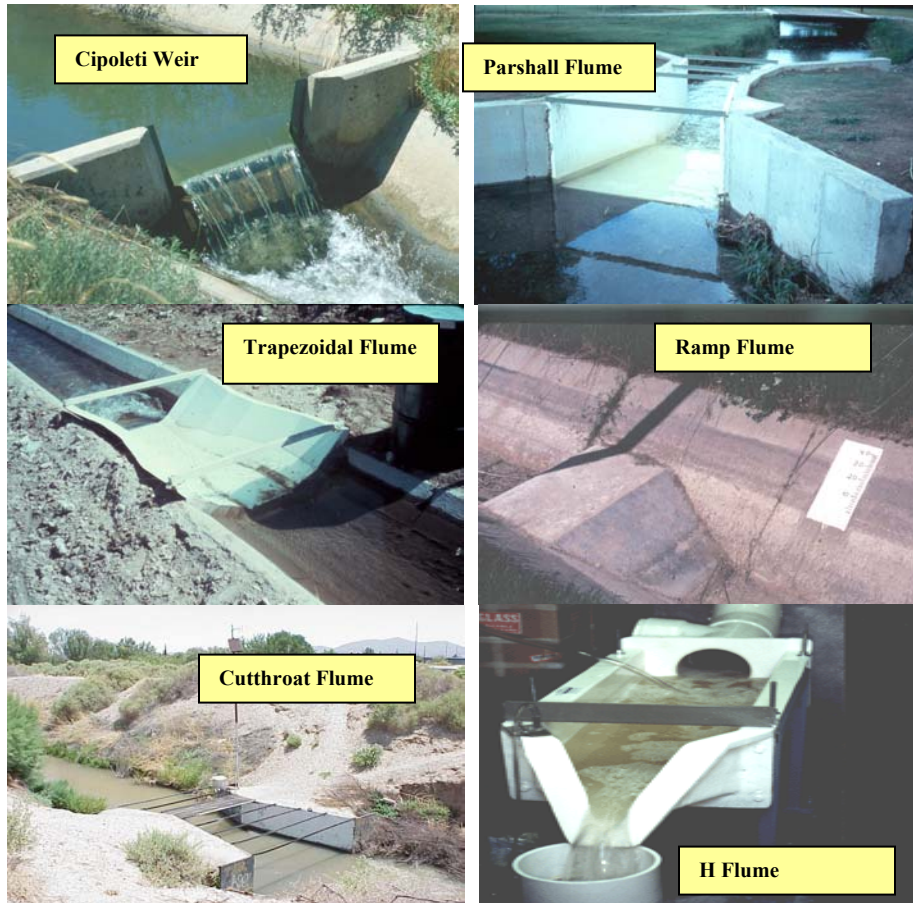


Fig. 3.8. Typical flow measuring devices for surface irrigation systems. (Fig. 3.8a,b, c and d from Dr. Robert W. Hill, USU Extension, Fig. 3.8e from Elephant Butte Irrigation District in New Mexico, and Fig 3.8 f from Tracom Fiberglass Products Web Page)

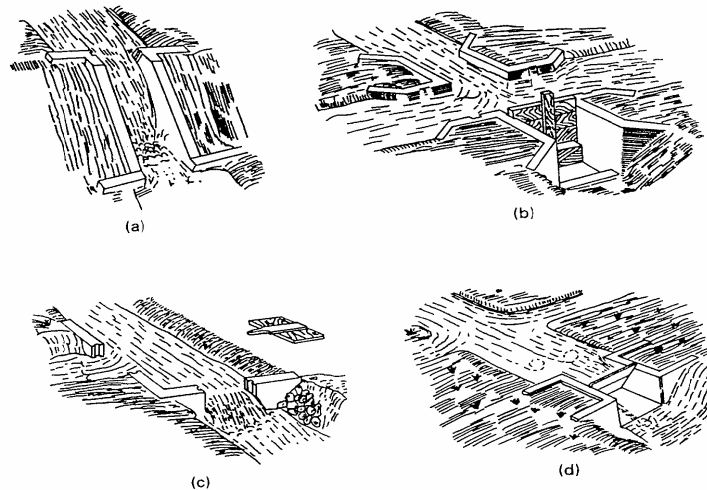
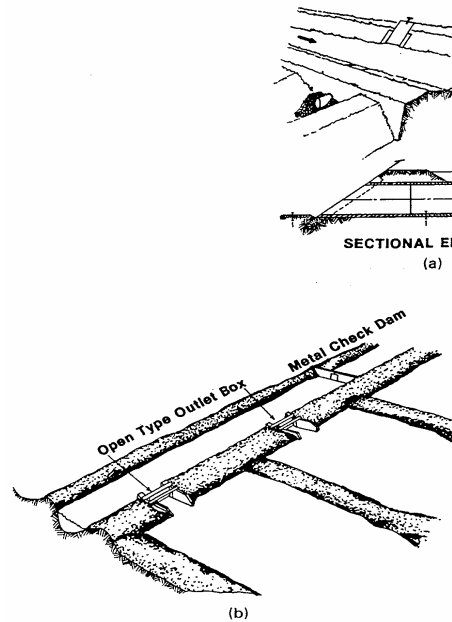


Figure 3.9 Examples of open-channel water control structures. (a) Simple drop structure. (b) Combination check-flow divider structure. (c) Division structure. (d) Simple check. (Er Skogerboe et al., 1971.)

If the field is irrigated from a head ditch, the methods used to spread the water over the field depend somewhat on the method of irrigation. For border and basin systems, open or piped outlets are generally used. Figure 3.10 shows a typical configuration for supplying water to a field from a head ditches using siphons. The can range in diameter from as small as 12 cm to as large as 20 cm. Another common way of irrigating furrows is aluminum or plastic gated pipe as shown in Fig. 3.11.



**Figure 3.9 Two head ditch outlets for border or basin irrigation. (a) Pipe outlet with gate control. (b) Outlet box with gate control. (U.S. Department of Interior, Bureau of Reclamation, 1951. See also Krautz and Malsajan, 1975.)**

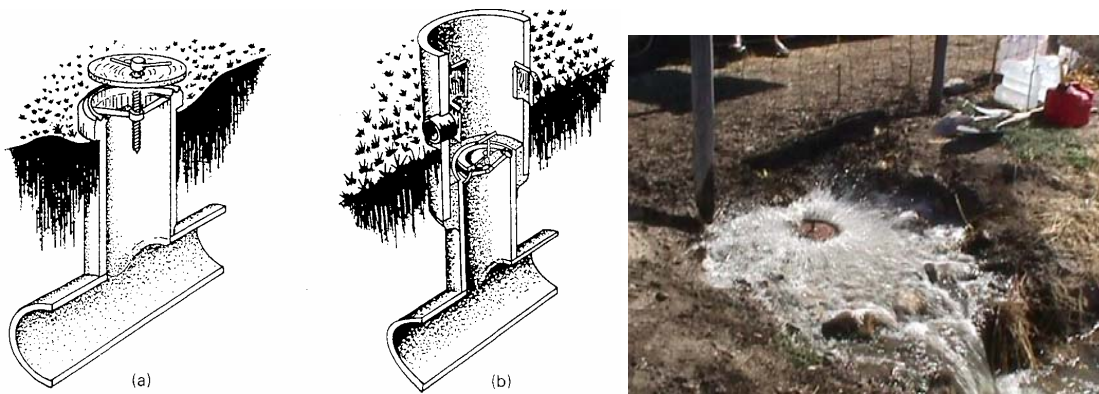


**Figure 3.10. Furrow irrigation using siphon tubes. (from Dr. R. W. Hill, USU Extension Irrigation Specialist)**



**Figure 3.11. Plastic gated pipe for furrow irrigation (From Dr. G. P. Merkley personal collection).**

The headland facilities for surface irrigation can also consist of surface or buried pipes. Basin and border irrigation systems usually employ buried pipes serving one or more gated risers within each basin or border. Two typical riser outlets are shown in Fig. 3.12. An illustration of the use of riser outlets to irrigate also shown in Fig. 3.12.



**Figure 3.12 Buried pipe headland distribution facilities (a) Alfalfa-valve-controlled riser (b) Alfalfa valve riser distributor for orchards. (After Skogerboe et al., 1971)**

### **REFERENCES**

- Criddle, W. D., S. Davis, C. H. Pair, and D. L. Shockley. 1956. *Methods of Evaluating Irrigation Systems*. USDA-SCS Handb. 82, U.S. Department of Agriculture, Soil Conservation Service, Washington, D.C.
- Krautz, D. G., and V. I. K. Malsajan. 1975. *Small Hydraulic Structures*. Vol. 1. Irrig. Drain. Pap. 26/1, United Nations, Food and Agriculture Organization, Rome.
- Skogerboe, G. V., V. T. Somoray, and W. R. Walker. 1971. *Check-Drop Energy Dissipation Structures in Irrigation Systems*. Water Manage. Tech. Rep. 9. Colorado State University, Fort Collins, Colo., May.
- U.S. Department of Agriculture, Soil Conservation Service. 1967. *National Engineering Handbook*, "Planning Farm Irrigation Systems." U.S. Government Printing Office, Washington, D.C., July, Sec. 15, Chap. 3.
- U.S. Department of Interior, Bureau of Reclamation. 1951. *Irrigation Advisors' Guide*. U.S. Government Printing Office, Washington, D.C.
- Walker, Wynn R. and Gaylord V. Skogerboe. 1987. *Surface Irrigation: Theory and Practice*. Prentice-Hall Inc., Englewood Cliffs, NJ. 386pp.

---

## **Chapter 4. Field Measurement Techniques**<sup>5</sup>

---

### **INTRODUCTION**

An evaluation of a surface irrigation system will identify various management practices and field layouts that can be implemented to improve the irrigation efficiency and/or uniformity of the system. The evaluation may show that achieving better performance requires a reduction in the flow and duration of flow at the field inlet or it may indicate that improvements require changes in the field size and topography. Perhaps a combination of several improvements will be necessary. Perhaps the most important objective of the evaluation is to improve surface irrigation performance. Certainly another is to provide the data necessary for improved design and operational procedures, which of course lead to improved efficiency and uniformity.

An evaluation should keep track of the water applied to a field and then segregate it into those portions that are infiltration and field tailwater. The water infiltrating the field surface is either stored in the root zone or percolates below. This information can be determined for individual points in the field or for a unit width of the field and then used to compute various efficiencies and uniformities.

One of the most important things that an evaluation accomplishes is the determination of average infiltration parameters for the field, usually as derived from measurements of advance rates. Direct measurement of infiltration characteristics can be made, however, typically under conditions that are different than under actual surface irrigation conditions. Estimating these parameters from advance data gives a reliable and accurate evaluation of the “average” field condition.

There are several publications describing the equipment and procedures for evaluating surface irrigation systems (Walker, 1989; Walker and Skogerboe, 1987; Merriam and Keller, 1978). A summary of these procedures and necessary equipment will be given in this chapter, but particular emphasis will be placed on two aspects of an evaluation. The first is the definition of the typical field infiltration relationship using the evaluation data describing the surface flow. The mathematical basis of the infiltration analysis will be the extended form of the Kostiakov-Lewis formula (Eq. 2.20, page 2-7). The second is the evaluation of the efficiency and uniformity of the irrigation event studied. Although many performance measures have been suggested, the five that will be noted herein: (1) application efficiency,  $E_a$ ; (2) requirement efficiency,  $E_r$ ; (3) distribution uniformity,  $DU$ ; (4) deep percolation ratio,  $DPR$ ; and (5) tailwater ratio,  $TWR$ .

### **FIELD PROCEDURES AND MEASUREMENTS**

#### **General Field Evaluation Procedure**

An evaluation of a surface irrigation system usually considers the field water balance discussed in Chapter 2 (see p. 2-2, Eq. 2.2). In most cases a short period to time extending no

---

<sup>5</sup> Taken from Walker and Skogerboe (1987), and Walker (1989).

more than a day before irrigation to 1-3 days after is selected for evaluation and thus is in effect an evaluation of a single irrigation. Where the field is furrow irrigated, a subset of several furrow is selected to represent the entire field. The procedure for conducting such an evaluation can be illustrated by considering the field measurements that are made. The most common field measurements that emerge from a system evaluation include:

1. The general layout of the field should be determined by noting such things as where the irrigation water comes from, where any tailwater has to exit the field boundaries, what cropping patterns are in use, etc. This information provides a general overview of the irrigation system.
2. The field geometry and topography are described by slope (and variations in slope), length, width, and in the case of furrow irrigation, the furrow shape. These parameters can be measured with tapes and an engineer's level. A more detailed look at the furrow shape measurements will be provided later.



3. The amount of water that should be applied can be determined by measuring the antecedent soil moisture using a method such as gravimetric sampling, neutron probes, a TDR instrument, etc. The number and spatial distribution of measurements will impact the accuracy of the measurement. These measurements should be made immediately before irrigation and within 3 days afterwards.
4. The inflow hydrograph (per furrow or per border or basin) needs to be measured carefully. If possible, the inflow should be controlled at one value during the entire evaluation. ;



5. The advance and recession of the water over the field surface, measured as the elapse time needed for the inflow to advance to a point on the field, or the elapse time until water has drained from the point following the cutoff of inflow, is required and should be among the most carefully made measurements in the field;



The runoff hydrograph (if the field is not diked), measured in the same manner as inflow;



### Advance and Recession Measurements

There are four phases of an irrigation event: (1) advance, (2) wetting or ponding, (3) depletion, and (4) recession. The typical field measurements employed for evaluating each of these phases are as follows.

#### ***ADVANCE PHASE***

To measure the rate which the advancing front moves across a surface-irrigated field, stakes are placed along the width and length of the field. A common spacing of these stakes is 30 m, except for small fields (< 2ha), where the spacing would be reduced to 1/6 to 1/10 of the field in order to provide a sufficient number of measuring points (six or more). The ground surface elevation at each stake should be surveyed to determine the grade of the irrigated field and any undulations in the ground surface.

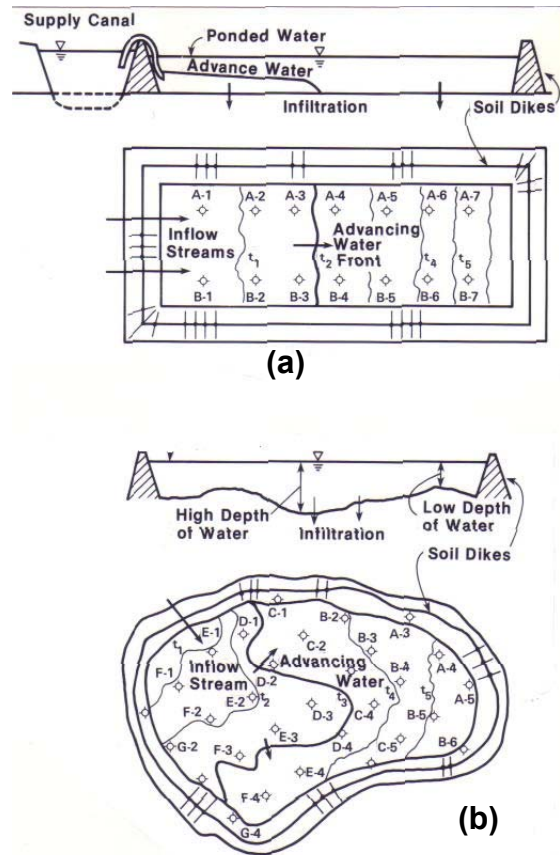
The clock time is recorded when the irrigation water supply is diverted onto the field and when the advancing front reaches each stake. A format for recording water advance data on furrow-irrigated fields is shown in Appendix Table 4.1. The format used for border or basin-irrigated fields is shown in Appendix Table 4.2, in which each of the three columns in the table represents a line of stakes along the field length (rather than the stakes along an individual furrow).

In Appendix Tables 4.1 to 4.3, the identification code ( $R_E$ ,  $F_A$ ,  $F_I$ ,  $I$ , and  $F_u$ ) is a means of accurately locating the particular furrow being measured:

- $R_E$  = region
- $F_A$  = site (or farmer's name or number)
- $F_I$  = field at site

I = irrigation event number  
 F<sub>u</sub> = furrow number

Another technique for measuring the rate of advance is to plot contours of the advancing front at periodic time intervals. Early in the irrigation season, prior to plant cover, the advancing front can be photographed to assist with the advance contouring. A grid of stakes is still needed and should be marked in such a manner that they can readily be identified, either for purposes of sketching or photographing. Some typical examples of the advancing front in regular-shaped and irregular-shaped basins are shown in Fig. 4.1.



**Figure 4.1 Schematic description of the advance phase in regular and irregular basins. (a) Regular basin. (b) Irregular basin. (adapted from Peri et al., 1979.)**

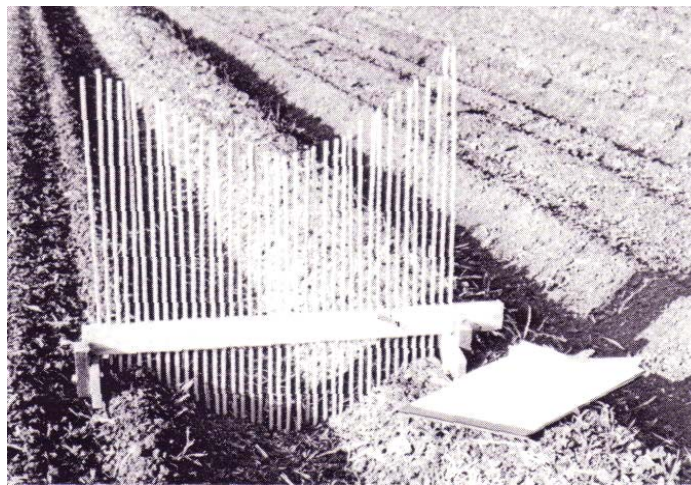
The cross-sectional geometry of furrows and corrugations is important when evaluating hydraulic flow characteristics and surface storage. For each furrow selected for evaluation, the cross-sectional geometry should be measured at two or three stations. A useful apparatus for determining the cross-section of furrows was shown in Fig. 4.2, and the format for recording the data is shown in Appendix Table 4.3. To minimize time in the field, this apparatus can be placed in the furrow and a photograph taken, which can then be analyzed in the office at a later date.

During irrigation of basins, borders, or furrows, the flow depth and water surface top width should be measured periodically at selected stations. These data can be combined with

cross-sectional flow areas to compute the surface storage at different times. A useful technique for measuring flow depth in basins and borders is to have a scale on each stake, which can consist of a metal staff gage or strips of colored tape around the stake.

### ***WETTING PHASE OR PONDING***

The term "wetting phase" is usually used for furrow and border irrigation where tailwater runoff can occur, whereas "ponding" is the preferred term for basin irrigation (no tailwater runoff). This phase begins when the advance phase is completed and ends when the irrigation water supply is cut off. After the advance phase is complete, the amount of surface water storage may be measured periodically using the techniques described above.



**Figure 4.2 Furrow profilometer for determining cross-sectional area. (Courtesy of G. P. Merkley.)**

### ***DEPLETION PHASE***

The depletion phase begins at the time of cutoff, after which the ponded water surface elevation declines and is recorded periodically. The depletion phase ends when any portion of the ground surface is bare of water.

### ***RECESSION PHASE***

For surface-irrigated fields the recession phase ends when surface water disappears at each measuring station and is recorded, as shown in Appendix Tables 4.1 or 4.2. The time difference at each measuring station between the clock time or cumulative time for advance and recession is the opportunity time,  $t_{opt}$ , for infiltration to occur. An example of advance, recession, and infiltration opportunity time for a furrow-irrigated field is shown in Fig. 4.3. For basin irrigation, it is advantageous to draw contours of the receding front at various times. Examples of advance and recession contours for a level basin are shown in Fig. 4.4.

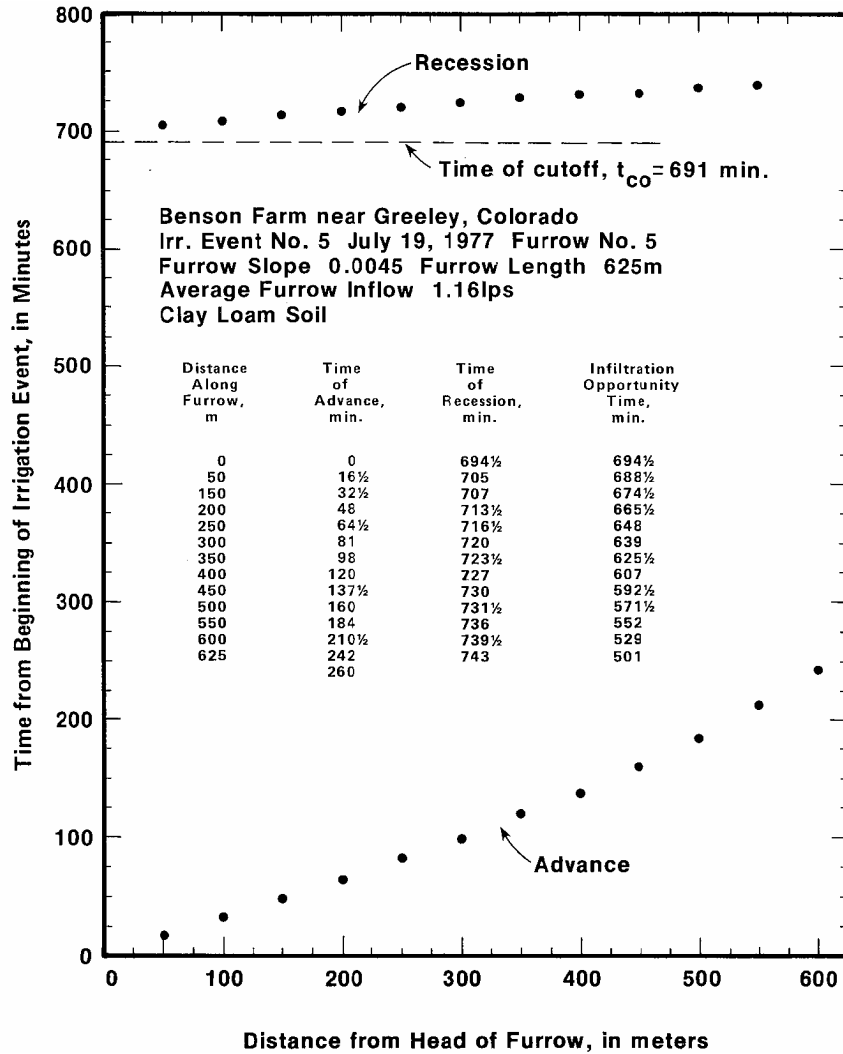


Figure 4.3 Advance and recession curves and infiltration opportunity times based on actual data for a furrow-irrigated field. (From Salazar, 1977.)

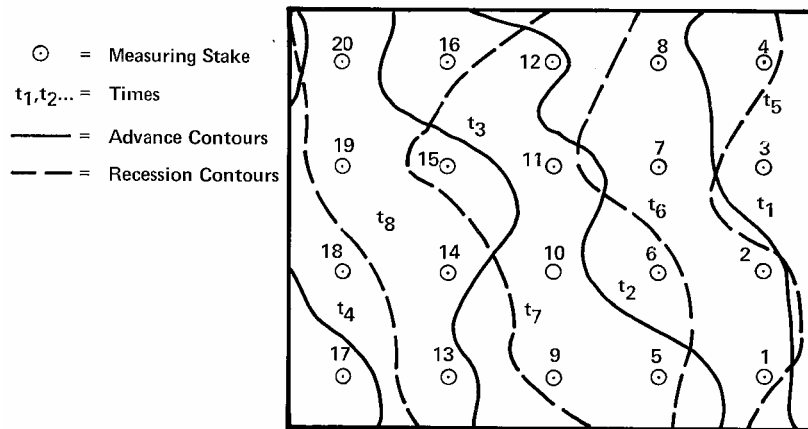


Figure 4.4. Advance and recession contours as measured in the field at various times for a regular graded basin irrigated field. (From Peri et al., 1979.)

## Infiltration

Not only is infiltration one of the most crucial hydraulic parameters affecting surface irrigation, but unfortunately, it is also one of the most difficult parameters to assess accurately in the field. The importance of knowing the infiltration function in order to describe the hydraulics of a surface irrigation event, along with the inherent difficulties in obtaining reliable estimates of this parameter, means that the investigator should expect to spend considerable time and effort in assessing infiltration before proceeding with the design of a surface irrigation system.

In the past, the three most commonly employed techniques for measuring infiltration were cylinder infiltrometers (Fig. 4.5), ponding, and inflow-outflow field measurements. For furrow irrigation, the blocked furrow method has been used, while a more recent technique refined at Utah State University is the recycling furrow infiltrometer. These field measurement techniques are described below. Later in this chapter analytical techniques for deriving the infiltration function based on field measurements collected during the advance phase are presented.

### CYLINDER INFILTROMETER

One of the most complete treatises on the use of cylinder infiltrometers for measuring infiltration was presented by Haise et al. (1956). The material below was taken largely from their publication, but with a few modifications based on more recent field experiences.

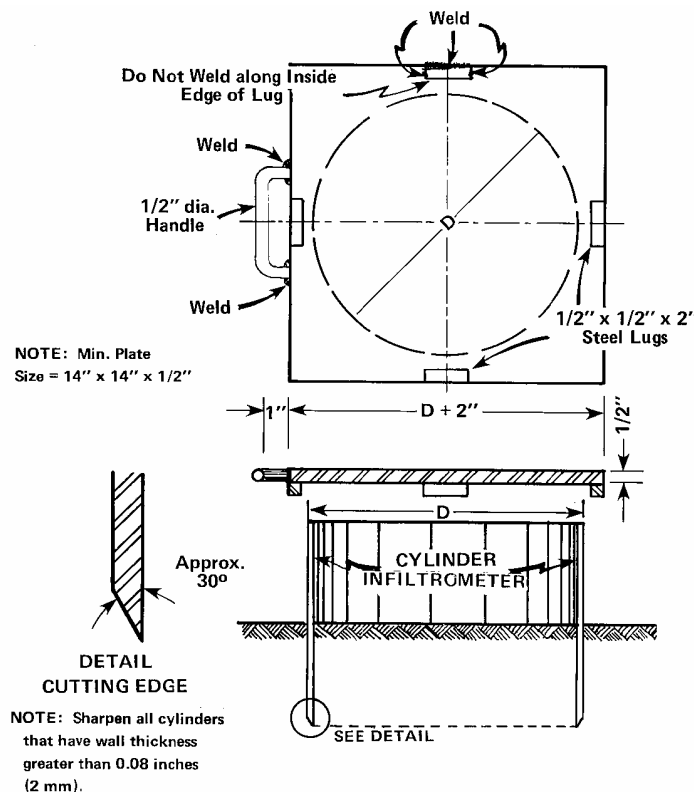


Figure 4.5. Details for fabricating a cylinder infiltrometer and a driving plate (Haise et al., 1956.)

A metal cylinder is used having a diameter of 30 cm or more and a height of about 40 cm. The cylinders should be constructed of smooth material to minimize skin friction when driving

the cylinder into the soil. Commonly, cold-rolled steel is used. The wall thickness of the cylinder should not exceed 2 mm (0.08 in., which is approximately 14 gage), unless a sharpened cutting edge is provided.

A driving plate is advantageous for setting on top of the infiltrometer to drive the cylinder into the ground. A piece of steel plate at least 10 to 15 mm thick (about 1/2 in.) is satisfactory for this purpose. The dimensions of this typically square plate should be 5 to 10 cm greater than the diameter of the cylinder. Placing lugs on the underside of the plate keeps it centered over the cylinder when driving the infiltrometer. Fabricating a handle on the plate provides for greater ease in carrying. A heavy driving hammer is needed for inserting the infiltrometer.

When installing cylinder infiltrometers, the procedure should be:

1. Select possible locations for three to five cylinders and examine the sites carefully for signs of unusual surface disturbance, animal burrows, might damage the cylinder, and so on. Avoid areas that may have been affected by unusual animal or machinery traffic. The individual cylinders used for a single test should be set close enough together so that they can conveniently be run simultaneously. Normally, they should be set within a 0.2 ha (1/2 acre) area.
2. Set a cylinder in place and press it firmly into the soil.
3. Place the driving plate over the cylinder and tamp with the driving hammer until the cylinder is driven to the desired depth. The level of the cylinder should be checked frequently to keep it oriented properly.
4. Construct a buffer pond unless the infiltrated water is not expected to reach the bottom of the cylinder prior to the end of the test. A satisfactory buffer pond can be constructed by throwing up a low dike around the cylinder. The inside toe of the dike should be at least 15 cm from the cylinder. In cropped fields or in areas where water supplies must be hauled to the test site, it may be desirable to use a metal cylinder to form the buffer pond. These buffer cylinders should be at least 30 cm larger in diameter than the cylinder infiltrometers. Outside cylinders, however, need not be as long as the cylinder infiltrometer nor driven as deep. Generally, buffer cylinders 20 cm long driven 5 to 10 cm into the soil will be adequate. Since these large-diameter cylinders are usually driven by tamping blows around their circumference, they should be constructed of 10-gage or heavier metal, or they should have a reinforcing strip welded around the top.

One or two water buckets, each having a capacity of roughly 10 liters, are needed to convey water to the infiltrometer. The usual irrigation water supply should be used since the chemical characteristics of the water can affect the infiltration rate.

A point gage can be used for measuring the water surface elevation in the cylinder and is easily fabricated. After the infiltrometers have been installed, the following operational procedure should be followed:

1. Fill the buffer pond (if used) with water to a depth approximately the same as will be used in the cylinder infiltrometer, as a safety precaution against leakage between the two surface reservoirs.

2. Fill the cylinder infiltrometer with a known volume of water (a depth of about 10 cm) so that the initial depth at time zero can be calculated.
3. Measure the water surface elevation as soon as possible. The cylinder should be filled quickly and the initial water surface observation made immediately, to reduce errors due to infiltration during this period.
4. Record the point gage or metal container gage reading and the time at which the observation was made (Appendix Table 4.4).
5. Make additional measurements at periodic intervals and record the data. Intervals between observations usually should be short (5 to 10 min) at the start of the test. After two or three measurements the intervals may be increased. After about the first hour, measurements at 30- to 60-min intervals will usually be sufficient. Observation frequencies should be adjusted to infiltration rates. For most soils, observations made at the end of 5, 10, 20, 30, 45, 60, 90, and 120 min and hourly thereafter, will provide good data. As a general rule, the infiltration between measurements should not be more than 2 cm (about 1 in.). Measurements should usually be continued until 4 h has elapsed. It is seldom necessary to extend the tests beyond the time required to put about 15 cm of water into the soil.
6. When the water level has dropped a few centimeters (2 to 5) in the cylinder, add sufficient water to return the water surface to its approximate initial elevation. Maintain the depth of water in the cylinder between 6 and 10 cm throughout the entire test. When water is added, be sure to record the level before and after filling. Keep the interval between these two readings as short as possible to avoid errors due to infiltration during the refilling period. In using the data, the refilling is assumed to be instantaneous.

Where an abnormally high or low infiltration value is indicated by a cylinder, it should be removed and the soil examined for possible causes and observations recorded.

At the conclusion of a test, remove the cylinders and clean them thoroughly. Mud-encrusted cylinders are difficult to drive and are apt to cause excessive soil disturbance. If the cylinders will not be used again for a week or more, a cloth soaked in oil should be used to coat the inside cylinder wall.

### ***PONDING METHODS***

Utilizing ponds constructed on the ground surface involves the same principles and procedures as discussed above for cylinder infiltrometers. The principal advantages of the ponding method are i) the ability to use larger ground surface areas, and ii) metal cylinders are not required.

The data can be recorded on the same format as that used with cylinder infiltrometers (Appendix Table 4.4).

### ***INFLOW-OUTFLOW METHODS***

Inflow-outflow methods for determining infiltration provide good measures of total infiltration, but not necessarily the distribution of infiltration along the length of an irrigated field. To estimate infiltration distribution, inflow-outflow measurements must be combined with

field measurements of advance in order to derive the infiltration function. These analytical techniques are presented later.

For basin irrigation, the volume of inflow is equal to the volume of infiltration. For small basins, where the time of advance is small compared to the total irrigation time, the infiltration can be assumed as essentially uniform over the basin area. Otherwise, the alternatives for evaluating the infiltration distribution are: (1) use cylinder infiltrometers; (2) employ the ponding method; or (3) combine inflow and advance data to derive the

For border irrigation, the difference between inflow and tailwater runoff measurements is an accurate measure of the total infiltration with time. However, to determine the infiltration distribution along the border length, either cylinder infiltrometers or ponds would have to be used (with some adjustment based on inflow-outflow measurements), or the infiltration function would be derived from a combination of inflow-outflow and advance data.

The measurement of infiltration for furrow irrigation differs from border irrigation in that it is feasible to make inflow-outflow measurements over a relatively short furrow length, say 30 to 100 m. One of the simplest techniques is to use small flumes at the head and tail of a furrow length. The greatest concern relates to the amount of backwater resulting from the downstream flume, which would result in more water intake than under normal operating conditions. To alleviate the backwater resulting from installing a constriction in the furrow, the outflow can be measured volumetrically as shown in Fig. 4.6 Two other techniques for measuring infiltration from irrigated furrows are described below.

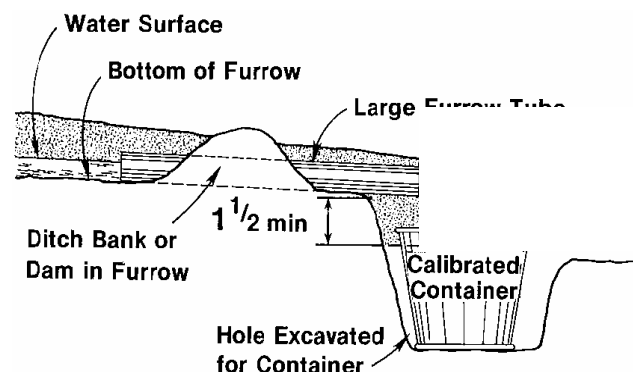


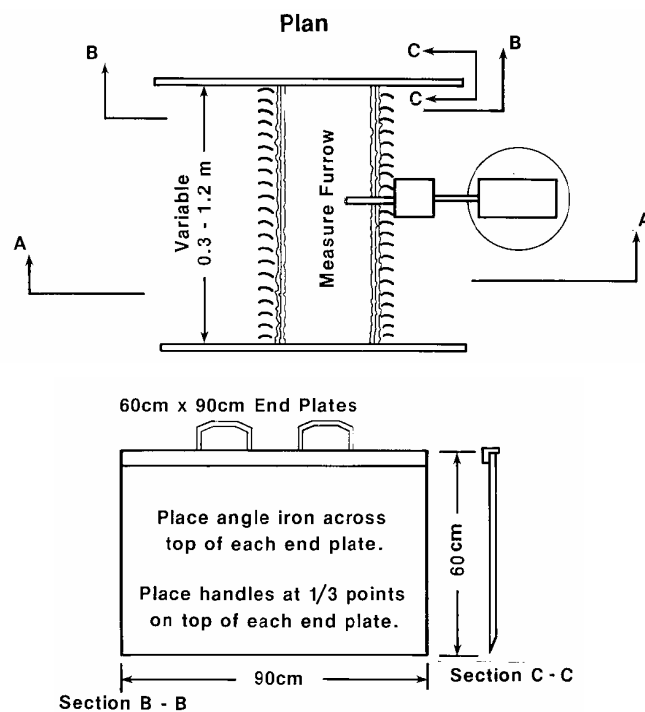
Figure 4.6 Volumetric measurement for outflow from an irrigated furrow. (From Shockley et al., 1959)

### ***BLOCKED FURROW METHOD***

The cylinder infiltrometer and ponding methods for measuring infiltration do not simulate the geometric conditions in a furrow. Infiltration from a furrow occurs around the wetted perimeter, which means that a significant portion of the total infiltration moves laterally through the furrow sides rather than vertically downward. Recognizing this problem, Bondurant (1957) developed a furrow infiltrometer which has come to be known as the blocked furrow method for measuring intake,

The schematic shown in Fig. 4.7 has been adapted from Bondurant (1957). In particular, the end plates have been made taller to reduce boundary effects (lateral subsurface soil moisture movement underneath the end plates). The float valve, reservoir, and water stage recorder are not mandatory since water can be placed by hand in the furrow being studied, using any type of container. However, whenever placing water in the furrow, the volume should be known. Also, prior to beginning the test, the relationship between depth and volume in the measure furrow should be established. For this purpose, furrow profilometer measurements could be made every 10 cm of furrow length, depending on the uniformity of furrow cross section. With this information, every time a known volume of water is placed in the measure furrow, the water surface elevation can be computed.

After installing the physical arrangement shown in Fig. 4.7, the procedure for the blocked furrow method would be the same as for the cylinder infiltrometer.



**Figure 4.7. Schematic of blocked furrow method of measuring infiltration. (Adapted from Bondurant, 1957.)**

In analyzing the data, a format similar to that for cylinder infiltrometers can be used (Table 4.4). The water stage recorder data are used to record clock time and cumulative volume of intake, which can be converted into a cumulative intake for the measure furrow.

### ***RECYCLING FURROW INFILTRMETER***

A recent innovation for evaluating infiltration from furrows is the recycling furrow infiltrometer. The primary advantage of this device is that both the geometric and hydraulic conditions in the field furrow are simulated. Thus the soil-water interface is being simulated more realistically. Suspended particles are kept in suspension rather than being filtered at the soil surface during infiltration and forming a more impermeable soil surface layer than would occur under usual conditions of furrow flow.

A schematic of the recycling furrow infiltrometer is shown in Fig. 4.8. A sump is excavated at each end of a furrow section roughly 5 to 6 m in length. The sumps should be carefully buried in the ground so that the sump inverts correspond with the furrow bed elevation, to avoid erosion at both ends of the furrow test section. Water is released from the water supply reservoir by opening the gate valve, and then regulated using the globe valve. The centrifugal pump then discharges the water via a hose into the furrow inflow sump, where it advances across the furrow test section and is collected in a tailwater sump. The sump pump then discharges the tailwater back into the water supply reservoir. The discharge volume from the sump pump is regulated by a float valve so that a constant water level is maintained in the tailwater sump.

The initial operation of this device creates some problems because of the short period required to complete the advance phase. To minimize this effect, the furrow inflow discharge rate can be set higher for a few minutes and then decreased to a constant level. Once the advance phase has been completed, the system will provide the necessary information about the rate of infiltration into the furrow as reflected in the rate at which the water surface is dropping in the water supply reservoir.

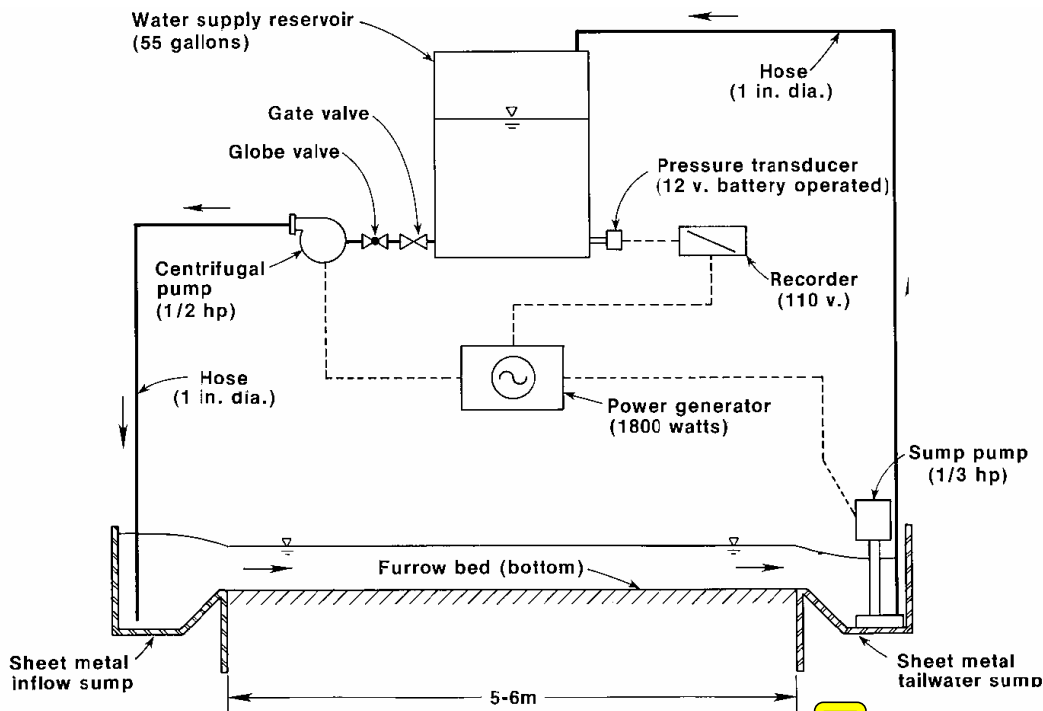


Figure 4.8 Schematic of a recycling furrow infiltrometer. (From Malano, 1982.)

A water balance can be written at any time after completion of the advance phase:

$$Q_{in} = Q_z + Q_{tw} \quad (4.1)$$

where  $Q_{in}$  = discharge rate from the centrifugal pump to the inflow sump,  $m^3/min$

$Q_z$  = discharge rate infiltrating into the soil,  $m^3/min$

$Q_{tw}$  = tailwater being discharged by the sump pump,  $m^3/min$

The infiltration discharge rate can also be written as

$$Q_z = A_f I \quad (4.2)$$

where  $I$  is the infiltration rate in m/min and  $A_f$  is the ground surface area in  $m^2$  being served by the furrow. Since the rate of fall in the water supply reservoir is also a measure of the infiltration rate,  $Q_z$ ,

$$Q_z = A_r \frac{dh}{dt} \quad (4.3)$$

where  $A_r$  is the cross-sectional area of the water supply reservoir in  $m^2$  and  $dh/dt$  is the recession rate of the water level in the supply reservoir in m/min. Setting Eqs. 4.1 and 4.3 equal to one another yields:

$$A_f I = A_r \frac{dh}{dt} \quad (4.4)$$

or

$$I = \frac{A_r}{A_f} \frac{dh}{dt} = C \frac{dh}{dt} \quad (4.5)$$

This also implies, then, that the cumulative infiltration in meters becomes

$$Z = C \cdot h \quad (4.6)$$

where  $h$  is the total change in water level drop in the water supply reservoir.

### Soil Moisture

The primary concern with water in irrigated agriculture is the replenishment of soil moisture in the plant root zone. The discussions above regarding flow measurement, infiltration, advance, recession, and so on, were intended to provide tools that can be used in conjunction with analytical techniques to predict soil moisture status. To calibrate or to verify these predictions, the soil moisture status must be measured periodically. More commonly, the soil moisture status is measured to determine when the next irrigation event should occur and how much water should be applied. For these purposes, the minimum soil-water parameters that must be measured are soil moisture content, bulk density, field capacity, and permanent wilting point.

Numerous techniques have been developed for evaluating soil moisture content,  $\theta$ , in the soil profile. In this chapter only two of the simplest methods, gravimetric sampling and the touch-and-feel method, will be described.

**Gravimetric sampling.** The standard method for determining soil moisture content is the gravimetric sampling method. The samples are usually collected using some type of sampling tube, either manually or power driven. In many cases, a shovel is used to collect a composite sample over some depth interval (e.g., 30 to 60 cm). The soil sample (approximately 100 to 200 g) is placed in an airtight container and weighed prior to placing in an oven maintained at 105°C (with the container cover removed so that the soil can dry). Usually, the soil sample is left in the oven for 24 hours, although a constant dry weight (less than 0.1% in weight during an hour) is usually achieved prior to this. The soil sample, with container and cover, is again weighed. Then using the predetermined tare weight of the container and cover, the soil moisture content is determined as discussed earlier.

**Touch and Feel.** As a means of developing a rough estimate of soil moisture status, the touch-and-feel method is frequently used. A handful of soil is taken and squeezed into a ball

about 2 to 3 cm in diameter. Then, knowing the soil type, the response of the squeezed soil can be related to the descriptions listed in Appendix Table 4.5 to arrive at the estimated depletion level. Merriam (1960) has developed a similar table, which gives the moisture deficiency in in./ft.

A person can develop a calibration for various soil types in a local region by collecting gravimetric samples whenever the touch-and-feel method is used. In this manner, the person will improve the accuracy of soil moisture status estimates at a later date when only the touch-and-feel method is used.

### **Bulk Density**

The bulk density, or bulk specific weight, of a soil mass,  $\gamma_b$ , is the dry weight of soil per unit bulk volume, which is expressed  $\text{g/cm}^3$ . Measurements of bulk specific weight are commonly made by extracting a soil sample, then measuring the bulk volume, and drying the sample in an oven to determine the soil moisture content. The dry weight of soil,  $W_b$ , is then used as follows to establish  $\gamma_b$ :

$$\gamma_b = \frac{W_b}{V} \quad (4.7)$$

Many methods have been developed for determining bulk density; most use a metal cylinder sampler that is driven to the desired depth in the soil profile either manually or mechanically. Since bulk density can vary considerably with depth and over an irrigated field, it is necessary to make a number of measurements in order to develop reasonable estimates of volumetric moisture content in the root zone.

### **Field Capacity**

Field capacity is a useful concept in irrigation, but cannot be precisely defined. The most common method of determining field capacity is using a pressure plate system that will apply a pressure to a saturated soil sample. When water is no longer leaving the soil sample, the soil sample is removed and placed in an airtight container for weighing. Then it is placed in an  $105^\circ\text{C}$  oven to determine the soil moisture content. This test should be run at 1/10 atm for a light sandy soil and 1/3 atm for a heavy clay loam soil. Frequently, the pressure plate system will be used to determine  $\theta$  for many capillary pressures (e.g., 1/10, 1/3, 1/2, 1, 2, 5, 10, and 15 atm), so that the soil moisture retention curve can be drawn for the particular soil type.

### **Permanent Wilting Point**

Most commonly, the soil moisture content at the permanent wilting point,  $\theta_{wp}$ , is taken as the moisture content corresponding to  $-15$  bar. Although  $\theta_{wp}$  can be somewhere between  $-10$  and  $-20$  bar, the soil moisture content normally varies very little in this range, so that using the data for  $-15$  bar provides a reasonable estimate. Also, an irrigation event usually occurs well before the root moisture has been reduced to  $\theta_{wp}$ , unless the water is not available when required.

The actual measure of permanent wilting point requires the growing of a reference crop (dwarf sunflower) in a series of watertight containers with an opening in each lid for a single plant to pass through (the air space between the opening and plant stem is filled with cotton to reduce soil evaporation). The soil moisture corresponding to  $-1/3$  bar is maintained until the third pair of leaves have developed. Then the plant is no longer watered. When all three pairs of

leaves have wilted (without regaining turgor after 10 to 15 h in a dark, humid chamber), the plant is cut at the soil surface and the soil moisture content measured and correlated to the permanent wilting point.

## ANALYSIS OF FIELD DATA

### Flow Shape

The most important volume balance computation in surface irrigation occurs during the advance phase of the irrigation. To make this computation, one must assume a mathematical form for describing the field's cross-sectional flow area, the form of the infiltration function and the mathematical form of the advance trajectory.

Many design analyses utilize the Manning Equation for flow area, Eq. 2.20 for infiltration, and a power advance relationship to describe the advance trajectory. Walker and Skogerboe (1987), Walker (1989) and Clemmens et al. (1998)<sup>7</sup> detail these analyses. The resulting volume balance equation is:

$$Q_0 t_x = \sigma_y A_0 x + \sigma_z k t_x^a x + \frac{I}{(1+r)} f_0 t_x x \quad (4.8)$$

in which  $Q_0$  is the inflow per unit width or per furrow at the upstream end of the field in  $m^3/\text{min}$ ;  $t_x$  is the time since inflow was initiated, in min;  $\sigma_y$  is the surface flow shape factor;  $A_0$  is the flow area at the flow's upstream end at time  $t_x$ , in  $m^2$ ;  $x$  is the distance from the inlet that the advancing front has traveled in  $t_x$  minutes, in m;  $\sigma_z$  is the "subsurface shape factor" describing the average infiltrated depth and is described by:

$$\sigma_z = \frac{a + r(1-a) + I}{(1+r)(1+a)} \quad (4.9)$$

where  $r$  is the exponent in the power advance equation:

$$x = p t_x^r \quad (4.10)$$

Equation 4.8 can be solved for any distance from the field inlet to define the volume balance at any time during the advance phase, but perhaps the most important is the distance from the inlet to the end of the surface irrigated field,  $L_T$ . Rewriting Eq. 4.8 in terms of  $L_T$  gives:

$$L_T = \frac{Q_0 t_L}{\sigma_y A_0 + \sigma_z k t_L^a + \frac{f_0 t_L}{1+r}} \quad (4.11)$$

where  $t_L$  is the time for the advance to reach the end of the field, in min.

In expressing either Eqs. 4.8 or 4.11 for variable distance  $x$ , one should be particularly

<sup>6</sup> Walker, W.R. and G.V. Skogerboe. 1987. *Surface Irrigation: "Theory and Practice"*. Prentice-Hall Inc., Englewood Cliffs, New Jersey. 386 pp.

<sup>7</sup> Clemmens, A. J., W. R. Walker, D.D. Fangmeier, and L. A. Hardy. 1998. "Design of surface systems". Chapter 14 In: *Design and Operation of Farm Irrigation Systems*. ASAE Monograph Number 3 (2nd Edition), R. L. Elliott, ed. St. Joseph, Michigan.

aware of how  $A_0$  is computed. Furrows generally exhibit a parabolic shape with a flat bottom as shown in Fig. 4.9. Borders and basins are evaluated by examining a “unit width” as shown in Fig. 4.10. To describe these shapes in terms of cross-sectional area, or wetted perimeter, either a regular geometric shape is assumed or the properties are determined by numerical integration.

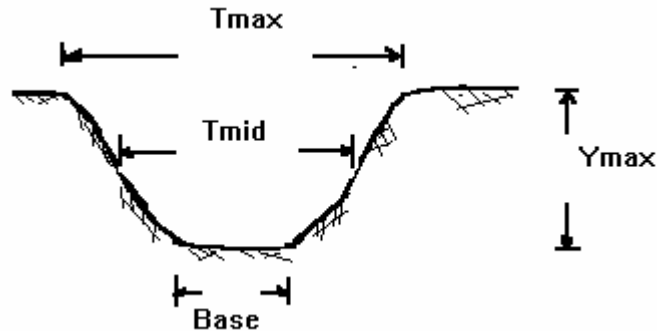


Figure 4.9. A Typical Furrow Cross-Section.

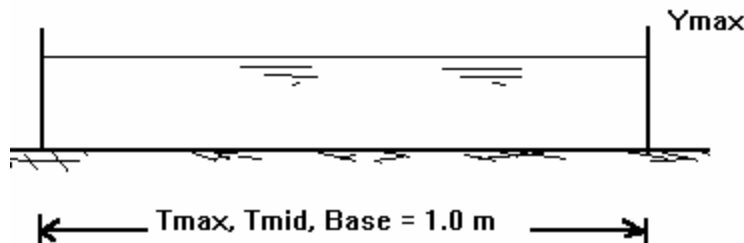


Figure 4.10. The Unit Width Concept for a Typical Border or Basin Cross-Section.

Elliott et al. (1983)<sup>8</sup> report on a field evaluation of more than 200 furrow evaluations at five sites in Colorado during 1979 and 1980 which involved furrow profile measurements along the furrow before and after irrigation. They found that cross sectional area and wetted perimeter could be expressed as simple power functions of depth, i.e.:

$$WP = \gamma_1 y^{\gamma_2} \quad (4.12)$$

where **WP** is the wetted perimeter of the furrow in m, **y** is the flow depth in m, and  $\gamma_1$  and  $\gamma_2$  are numerical fitting parameters; and

$$A = \sigma_1 y^{\sigma_2} \quad (4.13)$$

where **A** is the cross sectional area of the furrow in  $m^2$ , **y** is the flow depth in m, and  $\sigma_1$  and  $\sigma_2$  are numerical fitting parameters. The values of  $\gamma_1$ ,  $\gamma_2$ ,  $\sigma_1$ , and  $\sigma_2$  for borders and basins are 1.0, 0.0, 1.0, and 1.0 respectively. The hydraulic section can be computed by combining Eqs. 4.12 and 4.13:

$$A^2 R^{4/3} = \rho_1 A^{\rho_2} \quad (4.14)$$

<sup>8</sup>Elliott, R. L., W. R. Walker, and G. V. Skogerboe. 1983. Furrow Irrigation Advance Rates: A Dimensionless Approach. TRANS. ASAE (26)6:1722-1725, 1733.

in which,

$$\rho_2 = \frac{10}{3} - \frac{4\gamma_2}{3\sigma_2} \quad (4.15)$$

and,

$$\rho_1 = \frac{\sigma_1^{10/3}}{\gamma_1^{4/3}} \quad (4.16)$$

Again, the values  $\rho_1$  and  $\rho_2$  for borders and basins are respectively; 1.0 and 3.33. The cross-sectional flow area at the field inlet,  $A_o$ , can be determined for any flow,  $Q_o$  in  $m^3/min$  and field slope,  $S_o$ , greater than about 0.0001 as follows:

$$A_o = \left[ \frac{Q_o^2 n^2}{3600 S_o \rho_1} \right]^{1/\rho_2} \quad (4.17)$$

If the field has a slope less than 0.0001, then inlet area,  $A_o$ , will increase as the advance proceeds down the field and must be re-computed for each advance distance where the volume balance is to be evaluated. For this case, the value of the field slope,  $S_o$  is replaced by:

$$S_o = \frac{y_o}{x} \quad (4.18)$$

where  $y_o$  is the depth of flow at the field inlet in m and  $x$  is the advance distance in m. Equation 4.17 under this assumption becomes:

$$A_o = \left( \frac{Q_o^2 n^2 x}{3600} \right)^{\frac{3}{13}} \quad (4.19)$$

Measuring a furrow cross section in the field and then calculating the values of the empirical parameters in the preceding equations can be a tedious exercise. One simple approach is to use the four measurements shown in Figure 4.9 or 4.10 and then determine the parameters by numerical integration. This is easily accomplished with a hand held calculator or microcomputer. Another even simpler procedure is to define the  $\gamma_1$ ,  $\gamma_2$ ,  $\sigma_1$ , and  $\sigma_2$  values as follows:

$$\gamma_2 = \frac{\log \left[ \frac{\left[ \text{Base} + \sqrt{Y_{max}^2 + (T_{mid} - \text{Base})^2} + \sqrt{Y_{max}^2 + (T_{max} - T_{mid})^2} \right]}{\left[ \text{Base} + \sqrt{Y_{max}^2 + (T_{mid} - \text{Base})^2} \right]} \right]}{\log 2} \quad (4.20)$$

$$\gamma_1 = \frac{\left[ \text{Base} + \sqrt{Y_{max}^2 + (T_{mid} - \text{Base})^2} + \sqrt{Y_{max}^2 + (T_{max} - T_{mid})^2} \right]}{Y_{max}^{\gamma_2}} \quad (4.21)$$

$$\sigma_2 = \frac{\log \left[ \frac{\frac{Y_{max}}{2} \left( \frac{Base}{2} + T_{mid} + \frac{T_{max}}{2} \right)}{\frac{Y_{max}}{2} \left( \frac{Base}{2} + \frac{T_{mid}}{2} \right)} \right]}{\log 2} \quad (4.22)$$

$$\sigma_1 = \frac{\frac{Y_{max}}{2} \left( \frac{Base}{2} + T_{mid} + \frac{T_{max}}{2} \right)}{Y_{max}^{\sigma_2}} \quad (4.23)$$

### Calibrating Infiltration from Advance Data

In surface irrigation evaluations, the values of  $Q_o$ ,  $t_x$ , and  $x$  are measured during the advance phase at two points,  $x = 0.5L$  and  $x = L$  where  $L$  is the length of the field, m. Thus, the values of  $t_x$  that are measured are  $t_{.5L}$  and  $t_L$ . The values of  $A_o$  corresponding to  $(0.5L, t_{.5L})$  and  $(L, t_L)$  are computed from Eq. 4.17 or 4.19. Note that flow geometry parameters are required for this computation. A value of 0.77 is assumed for  $\sigma_y$ . The parameter  $\sigma_z$  is a function of  $a$  and  $r$  as indicated in Eq. 4.9. The unknowns in Eq. 4.8 are  $k$ ,  $a$ , and  $f_o$ . Solving for these provides the methodology for evaluating the average infiltration function along the length of a field using basic evaluation data.

The basic intake rate,  $f_o$ , needs to be determined independently. When the field evaluation includes measurements of inflow and outflow,  $f_o$  can be determined as:

$$f_o = \frac{Q_o - Q_{tw}}{L} \quad (4.24)$$

where  $Q_{tw}$  is the tailwater outflow per unit width or per furrow in  $m^3/\min$ . The difficulty in using Eq. 4.24 to determine  $f_o$  is that  $Q_{tw}$  will increase until the first term in Eq. 2.20 has become negligible – this may take as long as 24-36 hours. Thus, the basic intake rate is usually over-estimated by Eq. 4.24 with the result that the coefficient  $a$  in Eq. 2.20 is under-estimated (and may actually be negative) to preserve the volume balance of Eq. 4.8. Another approach is to assume a representative value from Tables 2.2 – 2.4 in Chapter 2 based on the general soil type found in the field. It is important to reiterate that any error in the actual value of  $f_o$  will be corrected by the values of  $k$  and  $a$  computed as indicated below.

Equation 4.8 can be written for the two points,  $(0.5L, t_{.5L})$  and  $(L, t_L)$ , to provide a simultaneous solution for  $k$  and  $a$  as follows:

$$a = \frac{\log \frac{V_L}{V_{.5L}}}{\log \frac{t_L}{t_{.5L}}} \quad (4.25)$$

and,

$$k = \frac{V_L}{\sigma_z t_L^a} \quad (4.26)$$

in which:

$$V_L = \frac{Q_o t_L - \sigma_y A_{x=L} L - \frac{1}{1+r} f_o t_L L}{L} \quad (4.27)$$

and,

$$V_{.5L} = \frac{Q_o t_{.5L} - \sigma_y A_{x=.5L} 0.5L - \frac{1}{1+r} f_o t_{.5L} 0.5L}{0.5L} \quad (4.28)$$

### Adjusting Infiltration for Wetted Perimeter

Three situations exist that may require an adjustment of the infiltration parameters, **a**, **k** and **f<sub>o</sub>**. The first is when values from Tables 2.2 – 2.4 need to be adjusted to distinguish between furrow and border/basin infiltration rates. Those values are provided to give the reader a starting point and do not necessarily apply exclusively to either furrow or border/basin infiltration. However, when comparing furrow and border/basin advance, recession, etc., it may be helpful to use the same curve number and distinguish between the two systems by adjusting the intake parameters.

The second case where intake coefficients might be modified is where one wishes to delineate the effects of wetted perimeter variations along a furrow. The basic argument for not making this adjustment is that simultaneous adjustments must also account for varying roughness and cross-section, both of which tend to minimize the effect of wetted perimeter.

And the third case occurs when the furrow infiltration coefficients have been defined using field advance data (and derived from one value of inflow, slope, length of run, etc.), but then the simulation or design analysis is based on a different values of field parameters. This is the most important of the three possible reasons for adjusting infiltration coefficients since improving simulation or design capabilities inherently implies field definition of infiltration.

### Adjusting Infiltration Parameters for Furrow Irrigation

The intake families tabulated in Tables 2.2 – 2.4 are not based on a particular surface irrigation condition. The wetted surface of furrows is usually less than that of a border so in comparing surface irrigation for a specific soil type, or NRCS curve number, it is necessary to adjust infiltration. There is a simple method of adjusting the infiltration **k** and **f<sub>o</sub>** coefficients for the ratio of wetted perimeter of a furrow to that of a border or basin and assumes the flow per unit width is the same in both cases.

Using Eqs. 4.12 – 4.16 as an approximation for furrow geometry, an equation for wetted perimeter as a function of flow, furrow slope, and furrow geometry can be developed as follows:

$$WP_o = \gamma_1 \sigma_1^{\sigma_2} \left( \frac{Q_o^2 n^2}{3600 S_o \rho_1} \right)^{\frac{\gamma_2}{\sigma_2 \rho_2}} \quad (4.30)$$

Then, a coefficient  $\xi$  is defined as:

$$\xi = WP_o^{\text{Infiltr-n}} \quad (4.31)$$

where **Infiltr-n** is a user-selected parameter which can be set to values between zero (where no wetted perimeter adjustment is made) to 1.0. Then Eq. 2.20 becomes;

$$Z = \xi (kt^a + f_o t) \quad (4.32)$$

### Adjusting Infiltration Parameters for Flowrate

The infiltration coefficients **k**, **a** and **f<sub>o</sub>** in Eq. 2.20 are defined for furrow irrigation at a specific discharge. If the simulated flow is significantly different from the discharge where infiltration is defined, the intake coefficients should be adjusted. Although there are a number of studies that have examined ways to adjust infiltration for wetted perimeter, most require a substantially more rigorous treatment of infiltration than can be accommodated here. Consequently, a relatively simple adjustment is used. From Eq. 4.30, the wetted perimeter is defined for the flow where the coefficients are determined:

$$WP_{\text{Infiltr}} = \gamma_1 \sigma_1^{\sigma_2} \left( \frac{Q_{\text{Infiltr}}^2 n^2}{3600 S_o \rho_1} \right)^{\frac{\gamma_2}{\sigma_2 \rho_2}} \quad (4.33)$$

where **Q<sub>infiltr</sub>** is the flow where the infiltration coefficients have been determined and **WP<sub>infiltr</sub>** is the corresponding wetted perimeter. Then the coefficient  $\xi$  is defined as:

$$\xi = \left[ \frac{WP_o}{WP_{\text{Infiltr}}} \right]^{\text{Infiltr-n}} \quad (4.34)$$

Then Eq. 4.32 is used to compute the cumulative infiltration.

### General Comment

The adjustment of infiltration for wetted perimeter is one topic of interest to model developers. It has generated some interesting debate. On one hand, the wetted perimeter is known to vary along the furrow with the decreasing flow and should be adjusted accordingly at each computational node. This concept is technically correct so far as discharge variation is concerned but relies also on the assumption that hydraulic roughness is constant along the furrow, an assumption that is known to be weak. The other side of the argument is that two other important parameters are varying in a fashion that compensates for the diminishing discharge along the furrow. The roughness increases along the furrow as the effects of less water movement produces less smoothing of the furrow surface, thus increasing wetted perimeter.

Also with less flow along the furrow the flow cross-section is less efficient. The result is that wetted perimeter remains nearly constant over a substantial length of furrow in spite of discharge reduction. This assumption was made in nearly all early versions of surface irrigation models. Report after report shows this to be adequate. The one area where there is little or no debate is for furrows on very low gradient or level fields.

Another important issue in this regard is the spatial variability of infiltration and roughness. A number of studies have shown that measurements of roughness,  $k$ ,  $a$  and  $f_0$  will exhibit a great deal of variation over a field. The analysis above assumes the values input will represent average values for the field. Thus, while attempts have been made to adjust infiltration and roughness for the effects noted above, there are no provisions for spatial variation.

### ***EVALUATION OF PERFORMANCE MEASURES***

High deep percolation losses aggravate waterlogging and salinity problems, and leach valuable crop nutrients from the root zone. Depending on the chemical nature of the groundwater basin, deep percolation can cause a major water quality problem of a regional nature. These losses can return to receiving streams heavily laden with salts and other toxic elements and thereby degrade the quality of water to be used by others. Deep percolation results when water is applied too long to the field and/or the variation of intake opportunity time is too large (inflow rates are too small). These two problems can be remedied by adjusting the time of cutoff,  $t_{co}$ , and in inflow rate,  $Q_0$ .

Runoff losses pose additional threats to irrigation systems and regional water resources. Erosion of the topsoil on a field is generally the major problem associated with runoff. The sediments can then obstruct conveyance and control structures downstream, including dams and regulation structures. Runoff losses can be reduced by adjusting the inflow downward, by collecting and recycling the tailwater, and by reducing the inflow after the advance has been completed (cutback).

With the measures of performance defined above, a broad range of assessments is possible and specific remedies identified. Application efficiency is the most important in terms of design and management since it reflects the overall beneficial use of irrigation water. In the next chapter, a design and management strategy will be proposed in which the value of application efficiency is maximized subject to the value of requirement efficiency being maintained at 95-100 percent. This approach thereby eliminates  $E_r$  from an active role in surface irrigation design or management. If the analysis tends to maximize  $E_a$ , distribution uniformity is not qualitatively important and may be used primarily for illustrative purposes

The field evaluation should identify at least some modifications that will improve efficiency and uniformity. These can be tested with simulation software. The easily identified problems such as applying too much or too little water, the poor distribution of infiltrated water over the field, excessive tailwater runoff or significant deep percolation losses should be evident. In planning to improve irrigation performance, it must be recognized that all of the parameters are interdependent. Therefore, when considering changes in inflow, time of cutoff, or field length, one must understand that the time of advance, infiltration, tailwater runoff and deep percolation will be affected simultaneously.

The most important surface irrigation “parameter” is the inflow discharge. The flow rate used on an irrigated field will significantly affect the time of advance, the volume of runoff and the erosion hazard. Utilizing high flow rates will maximize the potential for tailwater losses (except for basin irrigation) and erosion, but minimize the time of advance and thereby the variation in intake opportunity time along the field length.

For whatever discharge is being used, the ideal time of cutoff occurs when the infiltrated depth in the least watered portion of the field is equal to the irrigation requirement. Discharge and time of cutoff are the two operational hydraulic parameters, with time of cutoff being the easiest for the irrigator to modify. Again, the interdependence between inflow and cutoff time must be known in order to maximize the performance of a surface irrigation system.

Surface irrigation is critically dependent on the field topography. Undulations interrupt the flow of water and concentrate water in depressions. The high points tend to become saline. It is not a simple matter to apply the appropriate irrigation requirement; in fact, much greater depths are generally applied. Precision land leveling is an important aspect of improving the operation of surface irrigation systems, particularly for basins. Likewise, furrow preparation needs to yield channels of uniform depth and spacing. In short, land preparation should be considered an integral part of surface irrigation and not treated as an independent operation.

## **REFERENCES**

- Bondurant, J. A. 1957. Developing a Furrow Infiltrometer. *Agric. Eng.* 602-604. August.
- Haise, H. R., W. W. Donnan, J. T. Phelan, L. F. Lawhon, and D. G. Shockley. 1956. The Use of Cylinder Infiltrometers to Determine the Intake Characteristics of Irrigated Soils. Publ. ARS 41-7. U.S. Department of Agriculture, Agricultural Research Service and Soil Conservation Service, Washington, D.C., May.
- Ley, T. W. 1978. Sensitivity of Furrow Irrigation Performance to Field and Variables. Unpublished M.S. thesis, Colorado State University, Fort Collins, Colo.
- Malano, H. M. 1982. Comparison of the Infiltration Process Under Continuous and Surge Flow. Unpublished M.S. thesis, Utah State University, Logan, Utah.
- Merriam, J.L. and Keller, J. *Farm irrigation system evaluation: A guide for management.* 1978. Department of Biological and Irrigation Engineering, 4105 Old Main Hill, Logan, Utah, 84322-4105
- Merriam, J. L. 1960. Field Method of Approximating Soil Moisture for Irrigation. *Trans. ASAE* 3(1):31-32.
- Peri, G., G. V. Skogerboe, and D. I. Norum. 1979. Evaluation and Improvement of Basin Irrigation. Water Manage. Tech. Rep. 49B. Water Management Research Project, Colorado State University, Fort Collins, Colo., June.
- Salazar, L. J. 1977. Spatial Distribution of Applied Water in Surface Irrigation. Unpublished M.S. thesis, Department of Agricultural and Chemical Engineering, Colorado State University, Fort Collins, Colo.
- Shockley, D. G., J. T. Phelan, L. F. Lawhon, H. R. Haise, W. W. Donnan, and L. L. Myers. 1959. A Method for Determining Intake Characteristics of Irrigation Furrows. Publ. ARS 41-31. U.S. Department of Agriculture, Agricultural Research Service and Soil Conservation Service, Washington, D.C., April.
- Walker, W. R. 1989. *Guidelines for designing and evaluating surface irrigation systems.* FAO Irrigation and Drainage Paper 45, Food and Agriculture Organization of the United Nations, Rome, Italy. 137p.
- Walker, W.R. and G.V. Skogerboe. 1987. *Surface Irrigation: "Theory and Practice"*. Prentice-Hall Inc., Englewood Cliffs, New Jersey. 386 p.

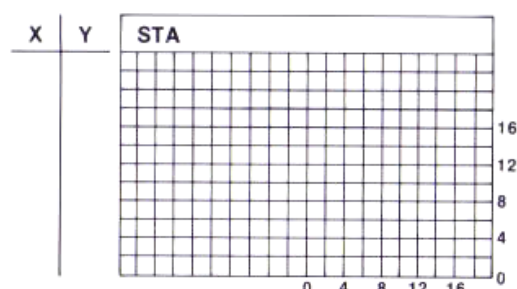
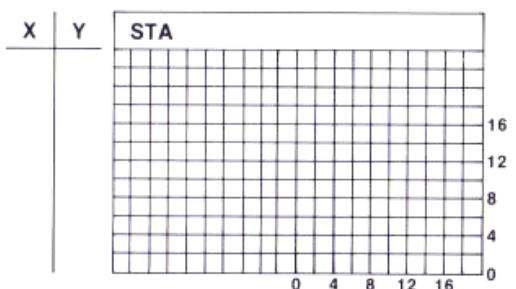
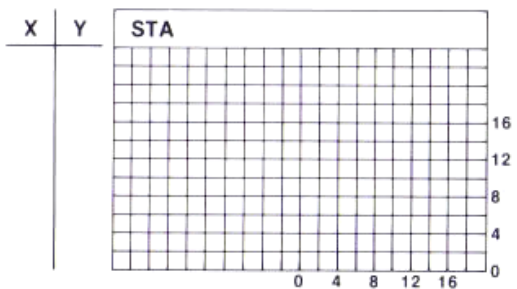
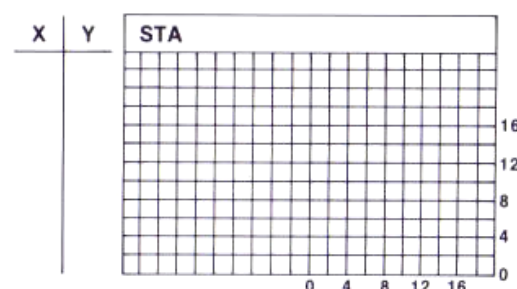
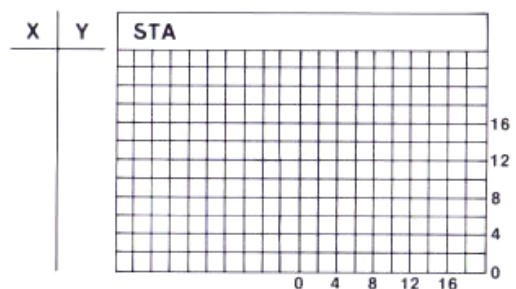
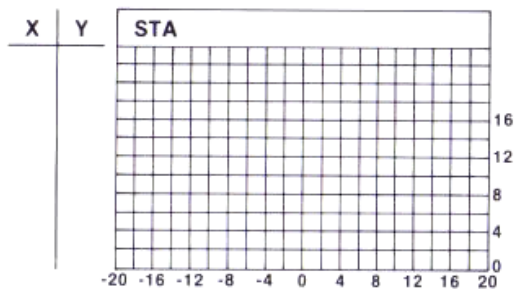




**TABLE 4.3. FORMAT FOR RECORDING FURROW CROSS-SECTIONAL DATA**

Ident (Location) ( $R_E$ ,  $F_A$ ,  $F_I$ ,  $I$ ,  $F_U$ ): \_\_\_\_\_ Length: \_\_\_\_\_ Date: \_\_\_\_\_

Observer: \_\_\_\_\_ Furrow Spacing: \_\_\_\_\_ Before \_\_\_\_\_  
 After \_\_\_\_\_  
 Irrigation



Source: From Ley (1978).




**TABLE 4.5. ESTIMATING SOIL MOISTURE STATUS BY THE TOUCH-AND-FEEL METHOD.**

Percent depletion	Feel or appearance of soil by general texture groups					
	Light		Medium		Fine and very fine	
	loamy loam	fine sand-fine	sandy	very fine sandy loam-silt		sandy clay loam-clay
100-75	Dry; fingers	loose; flows through		Powdery; dry; will not form a ball"		Hard, baked, cracked; sometimes has loose crumbs on surface
75-50	Appears to be dry; will not form a ball"			Dry, almost powdery; a ball can be formed under pressure; the ball is very crumbly and hardly holds its shape; will not ribbon; soil too crumbly <sup>b</sup>		Somewhat pliable; will ball under pressure <sup>a</sup>
50-25	Tends to ball under pressure but seldom holds together			Forms a pliable ball; soil does not stick to hand; no moisture on hand, just damp feeling; ribbons readily; soil has no slick feeling		Forms a pliable ball; ribbons readily; soil sometimes has a slick feeling
25-0	Forms a weak ball; breaks easily; has no slick feeling			Forms light plastic ball; slightly sticky; ribbons easily; solid; slick feeling, with moist particles left on hands		Easily ribbons out between fingers; has a slick feeling
0 (field capacity)	Upon squeezing no free water appears on soil but wet outline of ball is left on hand			Same as Light		Same as Light

<sup>a</sup>Ball is formed by squeezing a handful of soil firmly.

<sup>b</sup>Ribbon is formed by squeezing soil out between thumb and forefinger

 Source: After Merriam (1960).

## *Errata for Chapter 4*

1. On page 52 the discussion of flow cross-section for borders and basins implies a unit width of one meter. In this case the values of  $\gamma_1$ ,  $\gamma_2$ ,  $\sigma_1$ , and  $\sigma_2$  for borders and basins are 1.0, 0.0, 1.0, and 1.0 respectively. If English units are being used, the most likely unit width would be 1.0 feet (0.3048 m). In addition, some simulations may wish to simulate the entire border or basin width rather than a unit width. Thus, a more general description of the hydraulic shape parameters for these systems is as follows. The wetted perimeter and cross sectional area are:

$$WP = w \quad (4.35)$$

where  $WP$  is the wetted perimeter of the border or basin in m and  $w$  is the unit width actually used in m, and

$$A = wy \quad (4.36)$$

where  $A$  is the cross sectional area of the border or basin in  $m^2$ ,  $y$  is the flow depth in m. The hydraulic section can be computed by combining Eqs. 4.35 and 4.36:

$$A^2 R^{4/3} = \frac{1}{w^{4/3}} A^{10/3} \quad (4.37)$$

---

## Chapter 5. Design of Surface Irrigation Systems <sup>9</sup>

---

### **THE OBJECTIVE AND SCOPE OF SURFACE IRRIGATION DESIGN**

The surface irrigation system should replenish the root zone reservoir efficiently and uniformly so crop stress is avoided. Resources like energy, water, nutrients, and labor should be conserved. The irrigation system might also be used to cool the atmosphere around sensitive crops or to heat the atmosphere to prevent their damage by frost. An irrigation system must always be capable of leaching salts accumulating in the root zone. It may also be used to soften the soil for better cultivation or even to fertilize the field and apply pesticides.

The design procedures outlined in the following sections are based on a target application depth,  $z_{req}$ , which equals the soil moisture extracted by the crop. Design is a trial and error procedure. A selection of lengths, slopes, field inflow rates and cutoff times can be made that will maximize application efficiency for a particular configuration. Iterating through various configurations provide the designer with information necessary to find a global optimum. Considerations such as erosion and water supply limitations will act as constraints on the design procedures. Many fields will require a subdivision to utilize the total flow available within a period of availability. This remains a judgment that the designer is left to make after weighing all other factors that are relevant to the successful operation of the system. Maximum application efficiencies, the implicit goal of design, will occur when the least-watered areas of the field receive a depth equivalent to  $z_{req}$ . Minimizing differences in intake opportunity time will minimize deep percolation. Surface runoff will be controlled or reused.

The design intake opportunity time is defined in the following way from Eq. 2.20:

$$Z_{req} = k\tau_{req}^a + f_o\tau_{req} \quad (5.1)$$

where  $Z_{req}$  is the required infiltrated volume per unit length and per unit width or per furrow spacing and  $\tau_{req}$  is the design intake opportunity time. In the cases of border and basin irrigation  $Z_{req}$  is equal to  $z_{req}$ . However for furrow irrigation the furrow spacing must be introduced to reconcile  $Z_{req}$  and  $z_{req}$  as follows:

$$Z_{req} = z_{req}w \quad (5.2)$$

where  $w$  is the furrow to furrow spacing in meters.

A simple Newton-Raphson procedure can be used to solve for  $\tau_{req}$  given values of  $Z_{req}$ ,  $k$ ,  $a$ , and  $f_o$ :

---

<sup>9</sup> Taken from Walker and Skogerboe (1987), and Walker (1989).

$$(\tau_{req})_{i+1} = (\tau_{req})_i + \frac{Z_{req} - k(\tau_{req})_i - f_0(\tau_{req})_i}{\frac{ak}{(\tau_{req})_i^{1-a}} + f_0} \quad (5.3)$$

Beginning with an initial value of  $\tau_{req}$ ,  $(\tau_{req})_0$ , Eq. 5.3 is used to compute an improved solution,  $(\tau_{req})_1$ . When  $(\tau_{req})_{i+1}$  is within a tolerance value of  $(\tau_{req})_i$ , the solution is complete.

An engineer may have an opportunity to design a surface irrigation system as part of a new irrigation project where surface methods have been selected, or when the performance of an existing irrigation system requires improvement by redesign. In a new irrigation project, it is to be hoped that design is initiated after a great deal of irrigation engineering has already occurred. The selection of system configurations for the project is in fact an integral part of the project planning process. If a new or modified surface system is planned on lands already irrigated, the decision has presumably been based, at least partially, on the results of an evaluation at the existing site. In this case, the design is more easily accomplished because of the higher level of experience and data available.

In either case, the data required fall into six general categories (Walker and Skogerboe, 1987):

1. the nature of irrigation water supply in terms of the annual allotment, method of delivery and charge, discharge and duration, frequency of use and the quality of the water;
2. the topography of the land with particular emphasis on major slopes, undulations, locations of water delivery and surface drainage outlets;
3. the physical and chemical characteristics of the soil, especially the infiltration characteristics, moisture-holding capacities, salinity and internal drainage;
4. the cropping pattern, its water requirements, and special considerations given to assure that the irrigation system is workable within the harvesting and cultivation schedule, germination period and the critical growth periods;
5. the marketing conditions in the area as well as the availability and skill of labor, maintenance and replacement services, funding for construction and operation, and energy, fertilizers, seeds, pesticides, etc.; and
6. the cultural practices employed in the farming region especially where they may prohibit a specific element of the design or operation of the system.

### ***THE BASIC DESIGN PROCESS***

The surface irrigation design process is a procedure matching the most desirable frequency and depth of irrigation with the capacity and availability of the water supply. This process can be divided into a preliminary design stage and a detailed design stage.

#### **The Preliminary Design**

The operation of the system should offer enough flexibility to supply water to the crop in variable amounts and schedules and thereby allow the irrigator some scope to manage soil

moisture for maximum yields as well as water, labor and energy conservation. Water may be supplied on a continuous or a rotational basis in which the flow rate and duration may be relatively fixed. In those cases, the flexibility in scheduling irrigation is limited by water availability or to what each farmer or group of farmers can mutually agree upon within their command areas. On-demand systems should have more flexibility than continuous or rotational water schedules and are driven by crop demands. At the preliminary design stage, the limits of the water supply in satisfying an optimal irrigation schedule should be evaluated.

The next step in the design process involves collecting and analyzing local climate, soil and cropping patterns to estimate the crop water demands. From this analysis the amount of water the system should supply through the season can be estimated. Comparing the net crop demands with the capability of the water delivery system to supply water according to a variable schedule can produce a tentative schedule. Whichever criterion (crop demand or water availability) governs the operating policy at the farm level, the information provided at this stage will define the limitations of the timing and depth of irrigations during the growing season.

The type of surface irrigation system selected for the farm should be carefully planned. Furrow systems are favored in conditions of relatively high bi-directional slope, row crops, and small farm flows and applications. Border and basin systems are favored in the flatter lands, large field discharges and larger depths of application. A great deal of management can be applied where flexibility in frequency and depth are possible.

### **Detailed Design**

The detailed design process involves determining the slope of the field, the furrow, border or basin inflow discharge and duration, the location and sizing of headland structures and miscellaneous facilities; and the provision of surface drainage facilities either to collect tailwater for reuse or for disposal.

Land leveling can easily be the most expensive on-farm improvement made in preparation for irrigation. It is a prerequisite for the best performance of the surface system. Generally, the best land leveling strategy is to do as little as possible, i.e. to grade the field to a slope that involves minimum earth movement. Exceptions occur where other considerations dictate a change in the type of system, say, basin irrigation, and yield sufficient benefits to offset the added cost of land leveling.

If the field has a general slope in two directions, land leveling for a furrow irrigation system is usually based on a best-fit plane through the field elevations. This minimizes earth movement over the entire field, and unless the slopes in the direction normal to the expected water flow are very large, terracing and benching would not be necessary. A border must have a zero slope normal to the field water flow and thus will require terracing in all cases of cross slope. Thus, the border slope is usually the best-fit sub-plane or strip. Basins, of course, are generally level, i.e. no slope in either direction. Thus, terracing is required in both directions. To the extent the basin is rectangular; its largest dimension should run along the field's smallest natural slope in order to minimize leveling costs.

The detailed design process starts and ends with land leveling computations. These are inputs to the design process and need to be derived from other software. At the start, the field topography is evaluated to determine the general land slopes in the direction of expected water flow. This need not be the extensive evaluation that is needed to actually move the earth. In

fact, the analysis outlined earlier under the subject of evaluation is sufficient. Using this information along with target application depths derived from an analysis of crop water requirements, the detailed design process moves to the selection of flow rates and their duration that maximize application efficiency, tempered however by a continual review of the practical matters involved in farming the field later.

Field length becomes a design variable at this stage and again there is a philosophy the designer must consider. In mechanized farming, and possibly in animal power as well, long rectangular fields are preferable to short square ones in most cases except paddy rice. This notion is based on the time required for implement turning and realignment. In a long field, this time can be substantially less and therefore a more efficient use of cultivation and harvesting implements is achieved.

The next step in detailed design is to reconcile the flows and times with the total flow and its duration allocated to the field from the water supply. On small fields, the total supply may provide a satisfactory coverage when used to irrigate the whole field simultaneously. However, the general situation is that fields must be broken into 'sets' and irrigated part by part, i.e. basin by basin, border-by-border, etc. These subdivisions or 'sets' must match the field and its water supply.

Once the field dimensions and flow parameters have been formulated, the surface irrigation system must be described structurally. To apply the water, pipes or ditches with associated control elements must be sized for the field. If tailwater is permitted, means for removing these flows must be provided. Also, the designer should give attention to the operation of the system. Automation will be a key element of some systems.

The design algorithms herein utilize the volume balance methodology of Chapter 4. In Chapter 6, a more comprehensive analysis will be outlined that has also been encapsulated in the *SIRMOD III* software (described in Chapter 7). The volume balance methodology is used to compute the optimal values of inflow discharge and time of cutoff for the field configuration selected by the user.

## ***TWO BASIC DESIGN COMPUTATIONS***

The difference between an evaluation and a design is that data collected during an evaluation include inflows and outflows, flow geometry, length and slope of the field, soil moisture depletion and advance and recession rates. The infiltration characteristics of the field surface can then be deduced and the application efficiency and uniformity determined. Design procedures input infiltration functions (including their changes during the season), flow geometry, field slope and length, and determine the rates of advance and recession. Once advance and recession are computed, the field performance levels for various combinations of inflow and cutoff times are determined. Thus, two of the more important design computations in surface irrigation design are: (1) computation of the advance time; and (2) computation of the time when the inflow is shut off, or cutoff time,  $t_{co}$ .

### **Computation of Advance Time**

The time required for water to cover the field, the advance time,  $t_L$ , necessitates evaluation or at least approximation of the advance trajectory. Input data include the inflow discharge,  $Q_0$ ; the field length,  $L$ ; the infiltration coefficients  $k$ ,  $a$ , and  $f_0$ ; the field slope,  $S_0$ ; and

the flow cross-section area  $A_o$  (from Eq. 4.17) based on the cross-section geometry parameters  $\rho_1$  and  $\rho_2$ .

The volume balance equation was written in Chapter 4 as:

$$Q_o t_x = \sigma_y A_o x + \sigma_z k t_x^a x + \frac{1}{(1+r)} f_o t_x x \quad (5.4)$$

There are two unknowns in Eq. 5.4 –  $t_x$  and  $r$ . Refer to Chapter 4 for definitions of all variables associated with Eq. 5.4. The solution for  $t_L$  requires that the advance trajectory be defined at two points— $x = L$  and the halfway point,  $x = .5L$ . This involves a two level iterative procedure. The first is a simple successive approximation of  $r$  and the second is two Newton-Raphson procedures for  $t_L$  and  $t_{.5L}$ . In a step-by-step form this procedure is:

1. Assume an initial value of  $r$ ,  $r_{j=0}$ , of 0.6.
2. Using the Newton-Raphson procedure shown above for Eq. 5.3, compute the revised value of  $t_L$ :

$$(t_L)_{i+1} = (t_L)_i - \frac{Q_o (t_L)_i - \sigma_y A_o L - \sigma_z k (t_L)_i^a L - \frac{1}{(1+r_j)} f_o (t_L)_i L}{Q_o - \frac{ak\sigma_z L}{(t_L)_i^{1-a}} - \frac{1}{(1+r_j)} f_o L} \quad (5.5)$$

For the first iteration,  $(t_L)_1$ , assume  $(t_L)_0$  is  $5A_o L / Q_o$ .

3. Using the Newton-Raphson procedure again, compute the revised value of  $T_{.5L}$  (assume an initial value of  $t_{.5L}$  equal to 0.33  $t_L$ ):

$$(t_{.5L})_{i+1} = (t_{.5L})_i - \frac{Q_o (t_{.5L})_i - \sigma_y A_o \frac{L}{2} - \sigma_z k (t_{.5L})_i^a \frac{L}{2} - \frac{1}{(1+r_j)} f_o (t_{.5L})_i \frac{L}{2}}{Q_o - \frac{ak\sigma_z \frac{L}{2}}{(t_{.5L})_i^{1-a}} - \frac{1}{(1+r_j)} f_o \frac{L}{2}} \quad (5.6)$$

4. Compute the revised value of  $r_{j+1}$ :

$$(r)_{j+1} = \frac{\log(2)}{\log\left(\frac{t_L}{t_{.5L}}\right)} \quad (5.7)$$

When the values of  $r$  have converged within an acceptable tolerance, the procedure is completed and the value of  $t_L$  is now defined.

## Computation of the Cutoff Time

When water flow at the inlet to the field is shut off, the water on the surface will drain or recede from the field. If the downstream end of the field is blocked, this “recession” is primarily a function of infiltration and need not be computed directly. On the other hand, when the downstream end of the field is not blocked, it is necessary to determine how much additional intake opportunity time is involved during the recession phase and then adjust the cutoff time accordingly.

A key assumption in estimating the time of cutoff time is that the system design will refill the root zone at the downstream end of the field. This assumption can be written:

$$t_r = \tau_{req} + t_L \quad (5.8)$$

in which  $t_r$  is the total time from when water is first introduced to the field to the time when it has completely receded following the cutoff of the inflow, in minutes. The cutoff time is found by:

$$t_{co} = t_d - \frac{A_o L}{2Q_o} \quad (5.9)$$

where  $t_{co}$  is the time of cutoff in minutes since the inflow was first added to the field (duration of inflow),  $t_d$  is the “depletion” time in minutes,  $A_o$  is the flow cross-sectional area,  $L$  is the field length, and  $Q_o$  is the inflow discharge just prior to cutoff in  $m^3/min$ . The depletion time,  $t_d$ , is found iteratively as follows (assume the initial value of  $t_d$ ,  $(t_d)_0$  equals  $t_r$ ):

$$(t_d)_{i+1} = t_r - \frac{0.095n^{.47565} S_y^{.20735} L^{.6829}}{I^{.52435} S_o^{.237825}} \quad (5.10)$$

where

$$I = \frac{ak}{2} \left[ (t_d^{a-1})_i + \{(t_d)_i - t_L\}^{a-1} \right] + f_o \quad (5.11)$$

$$S_y = \frac{1}{L} \left( \frac{(Q_o - IL)n}{60\sqrt{S_o}} \right)^{0.6} \quad (5.12)$$

and  $n$  is the Manning roughness coefficient and  $S_o$  is the field slope. When the difference between  $(t_d)_i$  and  $(t_d)_{i+1}$  are within a tolerance value, the depletion time is computed.

## ***SURFACE IRRIGATION SYSTEM DESIGN***

There are five primary surface irrigation configurations:

- Free-draining systems;
- Blocked-end systems;
- Free-draining systems with cutback;
- Free-draining systems with tailwater recovery and reuse; and
- Surge flow systems.

The philosophy of design suggested here is to evaluate flow rates and cutoff times for the first irrigation following planting or cultivation when roughness and intake are maximum, as well as for the third or fourth irrigation when these conditions have been changed by previous irrigations. This will yield a design that will have the flexibility to respond to the varying conditions the irrigator will experience during the season.

### Input Data for the Surface Irrigation Design Process

Parameter Description	Mathematical	Comments
<i>First irrigation infiltration coefficients</i>	$a, k, f_0$	Should be based on field evaluations where possible
<i>Later irrigation infiltration coefficients</i>	$a, k, f_0$	
<i>Manning roughness coefficient for first irrigations</i>	$n_1$	Bare soil has a $n$ -value of about 0.04. Cropped surfaces
<i>Manning roughness coefficient for later irrigations</i>	$n_2$	Bare soil that has previously been irrigated typically has a
<i>Field length, width, slope, and unit width</i>	$L, W_f, S_o,$ and $w$	The unit width, $w$ , is 1.0 for borders and basins, or the
<i>Cross-sectional geometry parameters</i>	$T_{max}, T_{mid}, Y_{max},$ <b>Base</b>	Used to compute $\rho_1$ , and $\rho_2$ and then the inlet cross-
<i>Soil erosive velocity</i>	$v_{max}$	$v_{max}$ in erosive soils should be limited to 8-10 m/min. In less
<i>Water supply rate and duration</i>	$Q_T$ and $t_T$	It is assumed that $Q_T$ and $T_T$ are upper limits on supply and
<i>Target depth of application</i>	$Z_{req}$	Design computations will require a value of $Z_{max}$ . This is found by multiplying $z_{max}$ by $w$ .

### Free Draining Surface Irrigation Design

All surface irrigation systems can be configured to allow tailwater runoff. However, this reduces application efficiency, may erode soil or cause similar problems. It is therefore not a desirable surface irrigation configuration. However, where water is inexpensive the costs of preventing runoff or capturing and reusing it may not be economically justifiable to the irrigator. In addition, ponded water at the end of the field represents a serious hazard to production if the ponding occurs over sufficient time to damage the crop (“scalding”).

Furrow irrigation systems quite often allow the outflow of tailwater. Tailwater outflow from border systems is less common but remains a typical feature. As a rule, tailwater runoff is not a feature included in basin irrigation. Thus, the design algorithms herein for free draining field conditions apply only to furrow and border systems. Thus, if the user wishes to design a basin system with a free-draining outlet, it will be necessary to iteratively utilize the simulation features of the software described in Chapter 7.

#### *Free Draining System Design Procedure*

1. Calculate the maximum inflow discharge based on  $v_{max}$ :

$$Q_{max} = \left[ \frac{v_{max}^{\rho_2} n^2}{3600 \rho_f S_o} \right]^{\frac{1}{\rho_2-2}} \quad (5.13)$$

in which  $Q_{max}$  is the maximum non-erosive flow per unit width or per furrow,  $m^3/min$ . Use the Manning  $n$  value for the first irrigation conditions. Typical values for  $v_{max}$  are 10-15 m/min for stable soils and 8-12 m/min for less stable and erosive soils.

2. **Calculate the minimum inflow discharge, again using first irrigation conditions. For borders, this can be approximated by:**

$$Q_{min} = 0.000357L \frac{\sqrt{S_o}}{n} \quad (5.14)$$

where  $Q_{min}$  is the minimum flow in  $m^3/min/unit$  width needed to adequately cover the field and not “channel” through low areas. With the increased use of laser land leveling equipment, Eq. 5.14 is typically not needed. A more realistic estimate of  $Q_{min}$  is based on advance time. As a rule, the advance time should not exceed 24-36 hours. Otherwise, the uniformity and efficiency will be quite low. Thus, for both furrows and borders, the estimate of  $Q_{min}$  involves:

- i. Select a value of  $Q_o$  and using the procedure outlined in previously under “**Computation of Advance Time**”, compute  $t_L$ ;
  - ii. Repeat step i, successively reducing  $Q_o$  until  $t_L$  is 24 hours (1,440 minutes) or 36 hours (2160 minutes). This will be the  $Q_{min}$  value.
3. **Calculate the Application Efficiency,  $E_a$ , as a function of inflow discharge,  $Q_o$ . Use both first and later irrigation conditions. This involves the following steps:**

- i. Select an initial value of  $Q_o$  equal to  $Q_{min}$  and using the procedure outlined in the section “**Computation of Advance Time**” and “**Computation of the Cutoff Time**”, calculate  $t_{co}$ .
- ii. Calculate  $E_a$  as:

$$E_a = 100 \frac{Z_{req} L}{t_{co} Q_o} \quad (5.15)$$

- iii. Incrementally increase  $Q_o$  and repeat steps i and ii until a maximum value of  $E_a$  is found. This gives the optimal value of inflow discharge for both the initial irrigations and the later ones,  $q_1$  and  $q_2$ . There will usually be substantial differences.
4. Reconcile the optimal inflows found in step 3 with the total available flow  $Q_T$  and the time it is available,  $t_T$ :

- i. The total flow required to irrigate the field for the first irrigations is:

$$q_{T,1} = q_1 \frac{W_f}{w} \quad (5.16)$$

where  $q_{T,1}$  is the computed total required inflow and  $q_1$  is the optimal unit inflows found in step 3 for the first irrigation conditions. Similarly, for  $q_{T,2}$  using  $q_2$ :

$$q_{T,2} = q_2 \frac{W_f}{w} \quad (5.17)$$

Both  $q_{T,1}$  and  $q_{T,2}$  must be less than  $Q_T$ . If this is not the case, the field must be divided into two or more “sets”. The reconciliation begins by assuming the field will be irrigated all at one time. If this assumption fails, the field is divided in half and Eqs. 5.16 and 5.17 are re-evaluated. This procedure is repeated by dividing the field into four, eight, sixteen, individually irrigated parts until these equations produce an acceptable total required flow is found.

- ii. The total time required to irrigate the field during both first and later irrigations is found by:

$$t_T = N_s t_{co} \quad (5.18)$$

where  $t_T$  is the computed required time to irrigate the field in minutes and  $N_s$  is the number of sets determined in step i above. Two values of  $t_T$  are determined. The largest represents the controlling case.

- iii. By adjusting the number of sets, the designer should be able to reconcile the optimal unit width flows with the total available supply and the duration of the supply. If this cannot be accomplished, the design is infeasible and adjustments need to be made in the target application depth or as secondary considerations, field length and slope. If this is required, these changes are reflected in the input data, and the design process of this section repeated.

## Blocked-end Surface Irrigation Design

### Introduction

Blocking the end of basin, border, or furrow systems provides the designer and operator with the capability of achieving potential application efficiencies comparable with most sprinkle and drip irrigation systems. Of course the sprinkle and drip systems do not have to rely on the soil surface to convey and distribute water and are therefore more easily managed for high efficiencies.

While blocked-end fields have the potential for achieving high efficiencies, they also represent the highest risk to the grower. Even a small mistake in the cutoff time can result in substantial crop damage. Consequently, all blocked-end surface irrigation systems should be designed with emergency facilities to drain excess water from the field.

Figure 5-1 shows the four stages of typical blocked-end irrigation. In Fig. 5-1a, the water is being added to the field and is advancing. In Fig.5-1b, the inflow has been terminated and depletion has begun at the upstream end of the field while the flow at the downstream end continues to advance. This is important. Typical field practices for blocked-end surface irrigation systems generally terminate the inflow before the advance phase has been completed.

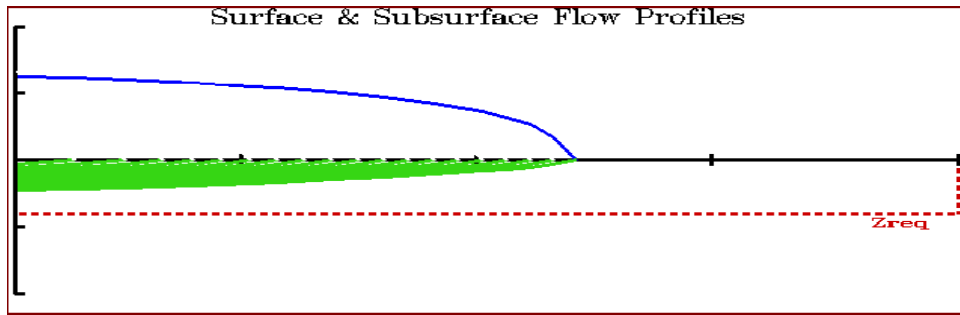


Figure 5-1a

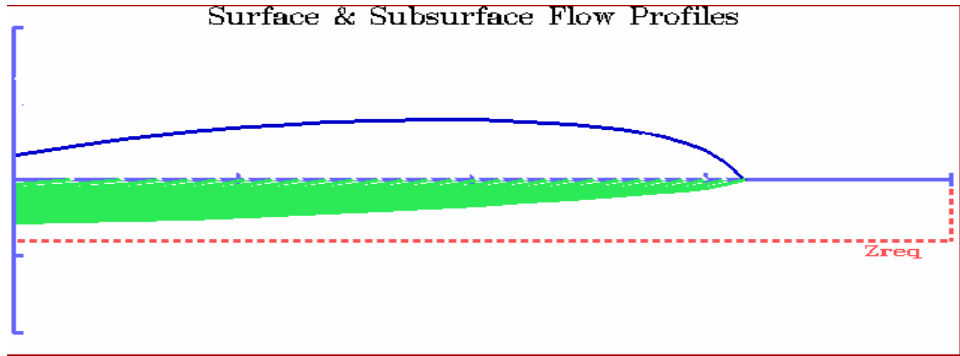


Figure 5-1b

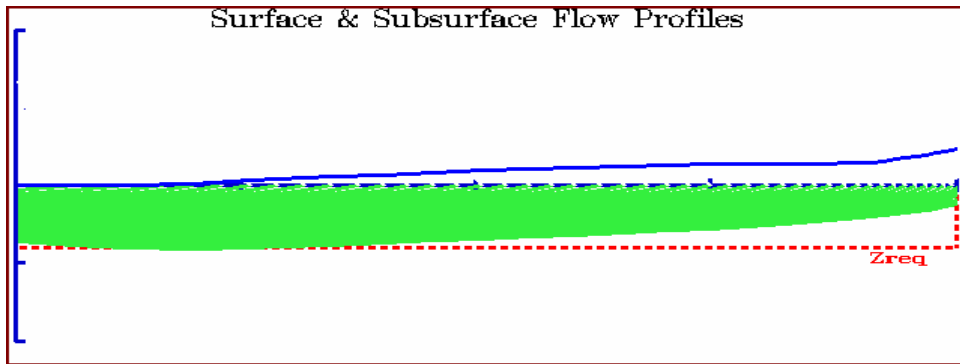


Figure 5-1c

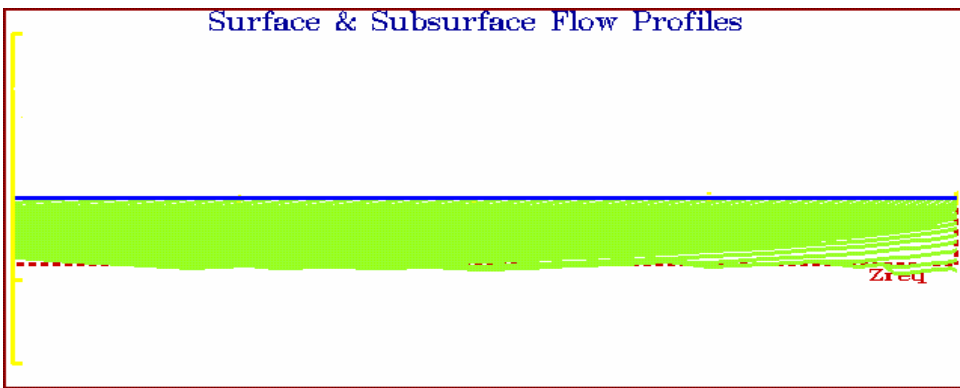


Figure 5-1d

In Fig. 5-1c, the depletion phase has ended at the upstream end, the advance phase has

been completed, and the residual surface flows are ponding behind the downstream dike. Finally, in Fig.5-1d, the water ponded behind the field dike has infiltrated and the resulting subsurface profile is uniform along the border are equal the required or target application. There is some under-irrigation at the upstream end of the field as well as near the downstream dike, and some over- irrigation elsewhere. The application efficiency, requirement efficiency, and uniformity of this example exceed 95%.

The dilemma for the designer of a blocked-end surface irrigation system is in determining the cutoff time. In practice, the cutoff decision is determined by where the advancing front has reached. This location may be highly variable because it depends on the infiltration characteristics of the soil, the surface roughness, the discharge at the inlet, the field slope and length, and the required depth of application. Until the development and verification of the zero-inertia or hydrodynamic simulation models (see Chapter 6), there was no reliable way to predict the influence of these parameters or to test simple design and operational recommendations. One simplified procedure based on extensive analysis with the *SIRMOD III* software is given below.

### ***Selecting the Field Control Point***

The field control point is the location where the least water will be applied. In free-draining fields, this point is normally at the downstream end of the field and the cutoff time is approximated by the sum of the required intake opportunity time,  $\tau_{req}$ , and the recession time,  $t_r$ . The difficulty in designing blocked-end systems is the field control point can be at one or more of three locations -- the upstream or downstream ends of the field as well as somewhere just upstream of the diked end of the border. The designer can choose one of these control points, but the only one which will allow a rational design procedure to evolve from a volume balance methodology is the upstream end of the field. Thus, design of a blocked-end surface irrigation system is fundamentally different than for a free draining system, and fortunately, it is significantly simplified by the location of the control point at the head of the field.

### ***Selecting the Cutoff Time***

By setting the field control point at the upstream end of the field, the cutoff time is approximated by the intake opportunity time,  $\tau_{req}$  and is independent of the advance time,  $T_L$  as suggested by Walker (1989). The specific cutoff time,  $T_{co}$ , may be adjusted for depletion as follows:

$$t_{co} = \xi \tau_{req} \quad (5.19)$$

where  $\xi$  is a simple fraction that reduces  $t_{co}$  sufficiently to compensate for the depletion time. As a rule,  $\xi$  would be 0.90 for light textured sandy and sandy loam soils, 0.95 for medium textured loam and silty loam soils, and 1.0 for clay and clay loam soils.

### ***Selecting the Inflow Rate***

The volume of water the designer would like to apply to the field is as follows:

$$V_{req} = z_{req} wL \quad (5.20)$$

If for instance the value of  $w$  is 1.0 meter, the calculations are based on the unit conditions and with  $L$  and  $z_{req}$  also in meters, then  $V_{req}$  is in  $m^3$ . If a blocked-end system could apply  $V_{req}$  uniformly, it would also apply water with a 100% application efficiency. Although a blocked-end system obviously cannot do so, the designer should seek a maximum value of

efficiency and uniformity. Since Eq. 5.20 represents the best first approximation to that design, it is at least the starting point in the design process.

Given that the inflow will be terminated at  $t_{co}$ , the inflow rate must be the following to apply  $V_{req}$  to the field:

$$Q_o = \frac{V_{req}}{t_{co}} \quad (5.21)$$

### ***Checking Design Limitations***

The procedure for selecting  $t_{co}$  and  $Q_o$  for blocked-end systems given above is very simple yet surprisingly reliable. However, as one's intuition must surely warn, it cannot work in every case and needs to be checked. The risk with the simplified procedure is that some of the field will be under-irrigated and thus using Eq. 5.21 to select a flow rate rather than a more rigorous such as suggested by Walker (1989) is "conservative" in a fundamentally different way. The procedure suggested by Walker (1989) will over-irrigate the field. It is thus conservative in terms of yield impacts due to water stress but it ignores the potential problems with excessive downstream ponding. Using Eq. 5.21 will minimize the risk of excessive downstream ponding but will leave at least some of the field under-irrigated and subject to moisture stress.

The specific limitations of this simplified blocked-end border design have not been thoroughly explored. However, it has been tested *within* a broad range of conditions involving intake functions ranging from heavy clay to sandy soils (NRCS Curves .05 through 2.00), field lengths ranging from 100 to 800 meters, field slopes ranging from 0.0 to 0.005, and target application depths ranging from 0.1 to 0.3 meters.

With the field control point at the field inlet, the utility and accuracy of this approach can be related exclusively to the water requirement efficiency,  $E_r$ , defined as the ratio of the volume of water actually applied to the soil moisture deficit to the target or required volume,  $V_{req}$ . For purposes of design, the  $E_r$  value should be at least 90- 95%. With this  $E_r$  criterion, the practical limits on the use of this simplified approach are as follows:

1. The upper limit on infiltration is about the NRCS intake curve number 1.00 or a sandy loam soil;
2. The upper limit on field slope should be about 0.1% and the minimum should be about 0.01%. The procedure does work for many level border conditions but they tend to yield lower values of  $E_r$ ;
3. The practical upper limit on application depths should be about 0.2 meters and the practical lower limit should be about 0.1 meters; and
4. Field lengths up to 800 m can be used for clay through silty clay loam soils (NRCS curves 0.25 - 0.50) while fields with lighter textured soils should be limited to about 400 m in length.

Even with these recommended limitations in mind, the simplified approach will provide some acceptable designs far outside the recommended limits. For example, applying this methodology to a border with a slope of 0.5%, a soil with a NRCS intake curve of 2.00, a field length of 500 meters, and a target depth of 0.2 meters will yield a design that achieves a potential application efficiency of 96% and an  $E_r$  value of 95%. This sort of exception is noted here to

once again make the suggestion that a blocked-end border design should be verified with a hydraulic simulation model.

There are two additional restrictions that should be noted for surface irrigation in general and blocked-end borders as well. Flow velocities above about 12-15 meters/minute in stable soils and 10-12 meters/minute in unstable soils will cause excessive field erosion. In block-end borders this condition can occur with target depths lower than 0.1 meter and slopes above 0.01%. Older surface irrigation writings that precede the laser land leveling era also recommend lower limits on flow velocity to avoid field channeling. This becomes a problem with application depths greater than 0.2 meter in heavy textured soils.

The application efficiency should be maximized subject to the limitation on erosive velocity, the availability and total discharge of the water supply, and other farming practices. The inflow should be reduced and the procedure repeated until a maximum  $E_a$  is determined.

### **Design Procedure for Cutback Systems**

The concept of cutback has been around for a long time. A relatively high flow is used at the start of an irrigation to speed the advance phase along and then a reduced flow is implemented to minimize tailwater. As a practical matter however, cutback systems have never been very successful. They are rigid designs in the sense that they can only be applied to one field condition. Thus, for the condition they are designed for they are efficient but as the field conditions change between irrigations or from year to year, they can be very inefficient and even ineffective. One adaptation of the concept was the “Cablegation” system developed at the USDA lab in Kimberly, Idaho.

The development and adaptation of Surge Flow has provided a realistic and flexible method of applying the cutback concept. This will be discussed in a later section.

### **Design of Systems with Tailwater Reuse**

The application efficiency of free-draining surface irrigation systems can be greatly improved when tailwater can be captured and reused. If the capture and reuse is to be applied to the field currently being irrigated, the design of such a system is somewhat more complex than the procedure for traditional free-draining systems because of the need to utilize two sources of water simultaneously. The major complexity of these reuse systems is the strategy for re-circulating the tailwater. One alternative is to pump the tailwater into the primary supply and then increase the number of operating furrows or the width of individual borders to utilize the additional flow. If the capture and reuse will occur on another field, then the design is simpler. In any case the tailwater reservoir and pumping system need to be carefully controlled and coordinated with the primary water supply.

To illustrate the design strategy for reuse systems, a design procedure for a common configuration is presented. The reuse system shown schematically in Fig. 5.2 is intended to capture tailwater from one set and combine it with the supply to a second set. A similar operating scenario prevails for each subsequent pair until the last set is irrigated when some of the tailwater must be stored until the next irrigation, dumped into a waste way, used elsewhere or used to finish the irrigation after the primary inflows have been shutoff.

If the surface runoff is to be captured and utilized on another field, the reservoir would collect the runoff from the  $n$  sets of Fig. 5.2 and then supply the water to the headland facilities of

the other field. This requires a larger tailwater reservoir but perhaps eliminates the need for the pump-back system.

### Input Data

The input requirements for the design of reuse systems are the same as discussed above relative to the free-draining systems including the computation of  $\tau_{req}$  from the intake coefficients and  $\rho_1$  and  $\rho_2$  from the flow geometry measurements.

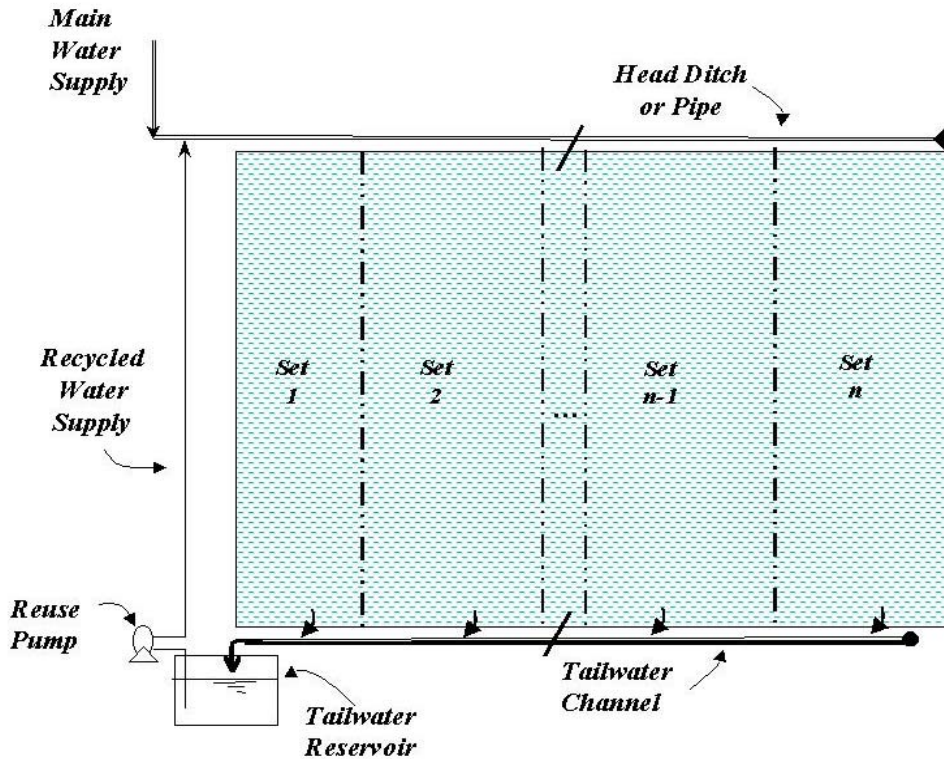


Figure 5.2. Illustration of a typical reuse configuration.

### Design of Reuse Systems for Recycling on Another Field

The simplest case of runoff reuse design is to collect the tailwater for irrigation on another field. In this design, it is not necessary to compute the application efficiency as a function of inflow discharge in an iterative fashion to optimize  $E_a$ . The procedure for these systems is as follows:

1. Compute the inflow discharge per unit width or per furrow that achieves as close as possible the following condition:

$$t_L = 0.30\tau_{req} \quad (5.22)$$

The discharge thus determined represents the best trade-off between the losses to deep percolation and the expense of constructing a larger tailwater recovery reservoir. Check the flow velocity,  $v_{max}$ , to insure the  $Q_0$  value is within the safe regime. If  $v_{max}$  is exceeded, reduce the  $Q_0$  value until the flow velocity equals  $v_{max}$ .

2. Compute the time of cutoff as described in “**Computation of the Cutoff Time**”.
3. Evaluate the subdivision of the field into sets that will accommodate the total available flow and the duration of the supply.
4. Compute the total infiltrated volume per unit width or per furrow, **VZ**:

- i. Having found the **r**-value as part of step 1 above, compute the value of **p** in Eq. 4.10:

$$p = \frac{L}{t_L^r} \quad (5.23)$$

- ii. Divide the field length into **m** equidistance stations and compute the advance time to each station:

$$t_j = \left( \frac{L_j}{p} \right)^{\frac{1}{r}}, \quad j = 0, 1, 2, \dots, m \quad (5.24)$$

- iii. Assume the recession is linear and compute the intake opportunity time at each station:

$$\tau_j = t_d + j \frac{t_r - t_d}{m} - t_j, \quad j = 0, 1, 2, \dots, m \quad (5.25)$$

- iv. Compute the total infiltrated volume at each station:

$$Z_j = k\tau_j^a + f_o\tau_j, \quad j = 0, 1, 2, \dots, m \quad (5.26)$$

- v. Calculate the total infiltrated volume, **VZ**, using the trapezoidal rule:

$$V_Z = \frac{L}{2m} (Z_o + 2Z_1 + 2Z_2 + \dots + 2Z_{m-1} + Z_m) \quad (5.27)$$

- vi. Compute the runoff volume per unit width or per furrow:

$$V_{ro} = Q_o T_{co} - V_Z \quad (5.28)$$

The runoff volume per set or from the entire field can be determined by multiplying **Vro** by the set width or the field width (number of furrows per set or in the field).

5. The application efficiency, **Ea**, of this system is:

$$E_a = 100 \frac{Z_{req} L}{V_Z} \quad (5.29)$$

6. Adjusting the total flow utilized facilitates the operation of this system for the later irrigations. Step 1 above is repeated using the infiltration and roughness conditions of the later irrigations. Then the **QT** value is computed by multiplying the set width (or furrows) in the sets determined in step 3. It is also necessary to

evaluate the total time this flow will be needed to insure that constraint is not binding.

### ***Design of Reuse Systems for Recycling on the Same Field***

The reuse of runoff on the same field is a more complicated matter than where the runoff can be used elsewhere entirely. The changes in infiltration from irrigation to irrigation, for instance, affect the size of the individual sets. In addition, since the runoff from the first set has to be added to the available flow for the second set, the size of each set changes across the field. In order to simplify both the design and operations of systems like Fig. 5.2, it is necessary and convenient to make several assumptions. First, the runoff volume from the first set will determine the capacity of the pump-back system. This is a conservative design. The difference in tailwater volumes between the second and subsequent sets as well as between first and later irrigations may be wasted. Secondly, the pump-back system needs to operate continuously, starting at the cutoff time for the first set and ending with the cutoff time of the last set. The recycled flow can thus be held constant to simplify the pump-back system and its operation. This will mean that some tailwater runoff during the later irrigations will have to be wasted. Lastly, the recycling system will be designed for field conditions of the first irrigations with the flow taken from the main water supply reduced to compensate for the higher runoff volumes expected during later irrigations.

The design procedure for this type of reuse system follows the first five steps outlined above. The execution of step 3 is made to insure the available flow and duration constraints are not exceeded, but the size of the sets will eventually be different as the recycled tailwater provide increased coverage in all of the sets beyond the first. In step 5, the runoff volume from only the first set is determined. As noted the differences between the runoff from the first set and subsequent sets will have to be wasted or stored for use on other fields.

After the fifth step has been completed, the design takes the following path:

The pump-back discharge is computed as:

$$Q_{pb} = \frac{N_1 V_z}{t_{co}} \quad (5.30)$$

where  $N_1$  is the width of the first set in meters or number of furrows.

The width or number of furrows in all the succeeding sets is:

$$N_i = \frac{Q_r + Q_{pb}}{Q_o} \quad (5.31)$$

The number of sets must fit the field evenly. After the first time through this procedure it may be necessary to repeat steps 1 – 5 in the previous section and step 6 –7 here using revised values of  $Q_o$  until the field is subdivided properly.

The application efficiency,  $E_a$ , of the first set is found from Eq. 5.29. For all the sets except the last one,  $E_a$  is found by:

$$E_a = 100 \frac{Z_{req} L}{V_z \left( 2 - \frac{N_l}{N_l} \right)} \quad (5.32)$$

and the application efficiency for the last set would be (assuming the tailwater from this set would have to be wasted):

$$E_a = 100 \frac{Z_{req} L}{\frac{(Q_T + Q_{pb}) t_{co}}{N_l}} \quad (5.33)$$

Finally, it is necessary to adjust the  $Q_T$  value for later irrigations as described in step 7 of the previous section.

### Design of Surge Flow Systems

A rational design procedure for surge flow systems has not been developed and thus is not included in the design features of the *SIRMOD III* software. This does not mean that design is not possible. The simulation capabilities of the software can simulate any Surge Flow configuration and through a trial and error process a design can be derived that is efficient and effective.

There are two critical design and operational rules for Surge Flow systems. First, the surges applied to the field during the advance phase should not coalesce, i.e., the advance front of one should not catch up and merge with a preceding surge. The second rule is that at the end of advance when cutback is desirable, the opposite should be facilitated – each surge should coalesce or merge.

The hydraulics of surges that do not coalesce behaves very much like the hydraulics of continuous flow at the same discharge, whereas the hydraulics of coalesced surges behaves very much like a cutback discharge. Thus, in the same irrigation management regime are the means to expedite rapid advance to minimize deep percolation as well as an effective way to and implement cutback to minimize tailwater runoff.

---

## Chapter 6. Simulation of Surface Irrigation Systems

---

### **SURFACE IRRIGATION'S GOVERNING EQUATIONS**

The heart of simulating various surface irrigation configurations and operational schemes is the numerical solution at the Saint-Venant Equations for conservation of mass and momentum. For conservation of mass:

$$\frac{\partial A}{\partial t} + \frac{\partial Q}{\partial x} + \frac{\partial Z}{\partial \tau} = 0 \quad (6.1)$$

and for conservation of momentum:

$$\frac{1}{Ag} \frac{\partial Q}{\partial t} + \frac{2Q}{A^2 g} \frac{\partial Q}{\partial x} + \left( 1 - \frac{Q^2 T}{A^3 g} \right) \frac{\partial y}{\partial x} - S_o + S_f = 0 \quad (6.2)$$

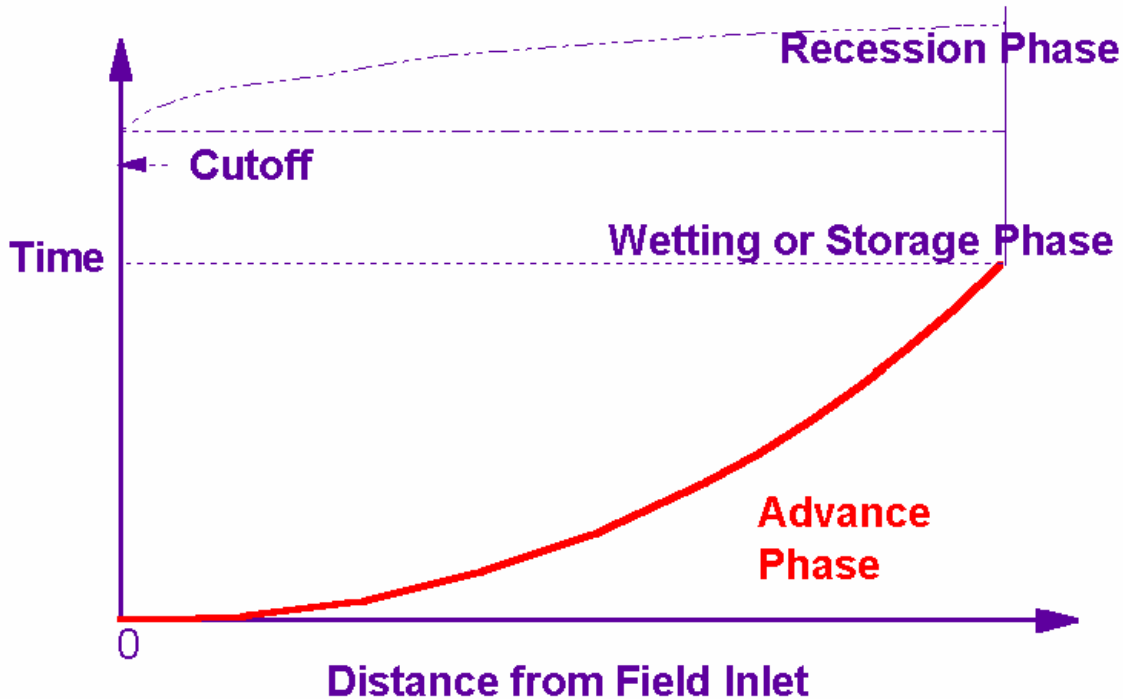
where **A** = cross-sectional area, m<sup>2</sup>;  
**Q** = discharge, m<sup>3</sup>/sec;  
**t** = elapse time, sec;  
**x** = distance from the field inlet, m;  
**τ** = intake opportunity time, sec;  
**Z** = cumulative intake, m  
**g** = acceleration of gravity, 9.81 m/sec<sup>2</sup>;  
**y** = flow depth, m;  
**S<sub>o</sub>** = field slope, m/m;  
**S<sub>f</sub>** = friction slope, m/m; and  
**T** = flow top width, m.

### **AN OVERVIEW OF THE NUMERICAL SOLUTION**

Solutions of Eqs. 6.1 and 6.2 describe the surface and subsurface water profiles as the irrigation stream first advances over the field, then reaches the end of the field and either ponds or runs off, and finally recedes from the field after the inflow is terminated. A schematic view of this process is shown in Fig. 6.1. A surface irrigation event is divided into three phases: (1) advance; (2) storage/wetting; and (3) recession. The solutions of Eqs. 6.1 and 6.2 differ during each of these phases as the boundary conditions at the field inlet and downstream end change. For instance, when the flow is introduced to the field, the inlet boundary is characterized by a known flow rate. The downstream boundary is actually the advancing front of the water moving over the field.

After the water has advanced to the end of the field, the downstream boundary is characterized by either the water running off the field or ponding behind the downstream dike. When the inflow is shut off, the inlet boundary has zero flow and as the water recedes this boundary moves downstream. It is also possible for the field to de-water at the downstream end

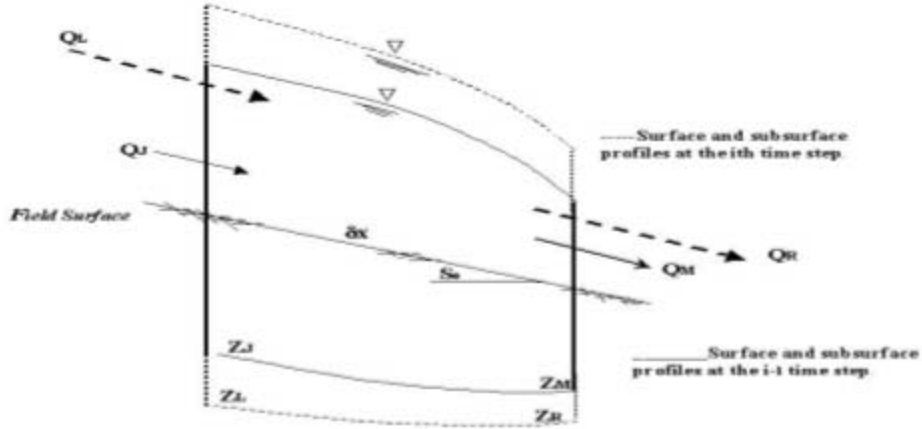
of the field with another receding front advancing upstream.



**Figure. 6. 1 The advance, ponding/wetting, and recession phases of surface irrigation.**

There are several numerical techniques for solving Eqs. 6.1 and 6.2. One of the first was the conversion of these partial differential equations to ordinary differential equations using the “Method of Characteristics”. This transformation resulted in four ordinary differential equations that can be solved simultaneously to describe the processes in Fig. 6.1. This solution requires very small time steps and is difficult to converge in the surface irrigation setting. As a result, solutions based on a deformable control volume were introduced in the early 1980’s that result in two algebraic equations that are more stable and easier to solve on modern microcomputers.

The basic concept of a deformable control volume is shown in Fig. 6.2. Here, a small slice of the water flowing over the field and infiltrating into the soil has been delineated. Its length is  $\delta x$  meters. We examine the small volume or cell over a period of time equal to  $\delta t$  minutes. During this time step, the flow into and out of the cell changes, thereby changing the cross-sectional flow area at both the upstream and downstream boundaries of the cell. In addition, the depth of infiltration increases during the time step. Figure 6.2 represents these changes with a subscript **L** or **R** to denote the condition at the end of the time step at the left and right boundaries respectively, and a subscript **J** or **M** to denote the conditions at the beginning of the time step at each boundary as shown. Note that the cell position relative to the field does not change. This is a “Eulerian” space – time solution. It is also possible to describe the flow by a cell that moves at an average flow velocity and deforms as it moves. This is a “LaGrangian” solution.



**Figure 6.2. Schematic of the Deformable Control Volume.**

When each deforming cell is represented in the time-space diagram of Fig. 6.2, they combine to completely describe the solution of Eqs. 6.1 and 6.2 as shown in Fig. 6.3. During each time step of the advance phase, the entire surface and subsurface profile expands by adding a triangular cell to represent the advancing front. The width of each cell is determined by the distance the water front advances during each time step. As each new triangular cell is formed, the previous one changes to a rectangular cell. After the flow reaches the end of the field, all the cells are rectangular as the entire profile no longer elongates. Finally, when the flow is shut off, cells are subtracted as the flow area approaches zero.

### Writing the Continuity Equation in Its Eulerian Form

The continuity equation, Eq. 6.1, states that the inflows to the deforming cell minus the outflows must be balanced by a change in the surface and subsurface storage within the cell. The Eulerian approximation of the cell's surface storage change is written:

$$\frac{\partial A}{\partial t} = \frac{[\phi(A_L - A_J) + (1 - \phi)(A_R - A_M)]}{\delta t} \quad (6.3)$$

where  $A$  represents the cross-sectional area of the cell in  $m^2$ ,  $\phi$  is a spatial averaging coefficient, and  $\delta t$  is the time step in min. Likewise for the cell's subsurface storage,

$$\frac{\partial Z}{\partial \tau} = \frac{[\phi(Z_L - Z_J) + (1 - \phi)(Z_R - Z_M)]}{\delta t} \quad (6.4)$$

in which  $Z$  is the infiltrated volume per unit width.

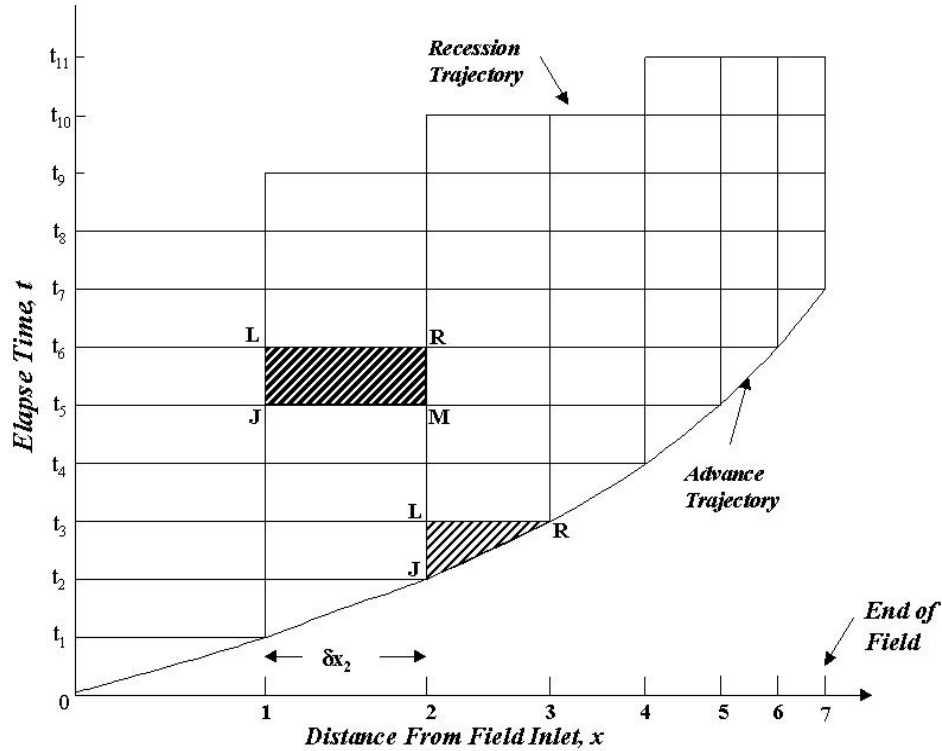


Figure 6.3. Eulerian space-time solution grid.

The net inflow to the cell during the period  $\delta t$  is:

$$\frac{\partial Q}{\partial x} = \frac{[\theta(Q_L - Q_R) + (1 - \theta)(Q_J - Q_M)]}{\delta x} \quad (6.5)$$

where  $\theta$  is a time averaging coefficient.

The values of  $\theta$  and  $\phi$  used by *SIRMOD III* are the same for both parameters, 0.60. Other models use different values, typically 0.51 to 0.55. Some simulations are unstable and fail to converge. *SIRMOD III* checks for this condition and modifies several internal parameters to correct the problem. One of these automatic modifications is made to increase the values of  $\theta$  and  $\phi$ . As a rule, convergence problems are more related to the size of the time step and the spatial scale than the time and space averaging coefficients.

### Writing the Momentum Equation in Its Eulerian Form

The actual function of the momentum conservation equation is to describe the shape of the surface water profile in time and space. Thus, it is different than the continuity equation as it does not include infiltration. The reason is that in the derivation of the equation, it is assumed that momentum loss from the surface flow as some of it infiltrates is negligible.

The numerical solution uses a slightly different form of Eq. 6.2. When the equation is multiplied by  $A$  it becomes:

$$\frac{1}{g} \frac{\partial Q}{\partial t} + \frac{2Q}{Ag} \frac{\partial Q}{\partial x} + \left( A - \frac{Q^2 T}{A^2 g} \right) \frac{\partial y}{\partial x} - AS_o + AS_f = 0 \quad (6.6)$$

Then noting that  $\partial \mathbf{A} = \mathbf{T} \partial y$  and  $\partial \mathbf{P} = \mathbf{A} \partial y$  the second and third terms can be rewritten as:

$$\frac{\partial}{\partial x} \left\{ \mathbf{P} + \frac{\mathbf{Q}^2}{\mathbf{A}g} \right\} = \frac{2\mathbf{Q}}{\mathbf{A}g} \frac{\partial \mathbf{Q}}{\partial x} + \left( \mathbf{A} - \frac{\mathbf{Q}^2 \mathbf{T}}{\mathbf{A}^2 g} \right) \frac{\partial y}{\partial x} \quad (6.7)$$

so an alternate form of Eq. 6.2 is:

$$\frac{1}{g} \frac{\partial \mathbf{Q}}{\partial t} + \frac{\partial}{\partial x} \left( \mathbf{P} + \frac{\mathbf{Q}^2}{\mathbf{A}g} \right) - \mathbf{A}S_o + \mathbf{D} = 0 \quad (6.8)$$

where  $\mathbf{P}$  is the net hydrostatic pressure acting on the cell per unit weight of water and  $\mathbf{D}$  is the drag, or the product of friction slope and area. The corresponding Eulerian terms are thus:

$$\frac{1}{g} \frac{\partial \mathbf{Q}}{\partial t} = \frac{1}{g} \left[ \frac{\phi(\mathbf{Q}_L - \mathbf{Q}_J) + (1-\phi)(\mathbf{Q}_R - \mathbf{Q}_M)}{\delta t} \right] \quad (6.9)$$

$$\frac{1}{\partial x} \left[ \mathbf{P} + \frac{\mathbf{Q}^2}{\mathbf{A}g} \right] = \frac{\theta \left[ \left( \mathbf{P} + \frac{\mathbf{Q}^2}{\mathbf{A}g} \right)_R - \left( \mathbf{P} + \frac{\mathbf{Q}^2}{\mathbf{A}g} \right)_L \right]}{\delta x} + \frac{(1-\theta) \left[ \left( \mathbf{P} + \frac{\mathbf{Q}^2}{\mathbf{A}g} \right)_M - \left( \mathbf{P} + \frac{\mathbf{Q}^2}{\mathbf{A}g} \right)_J \right]}{\delta x} \quad (6.10)$$

$$-\mathbf{A}S_o = -S_o \left\{ \theta \left[ \phi A_L + (1-\phi) A_R \right] + (1-\theta) \left[ \phi A_J + (1-\phi) A_M \right] \right\} \quad (6.11)$$

and

$$\mathbf{D} = \theta \left[ \phi \mathbf{D}_L + (1-\phi) \mathbf{D}_R \right] + (1-\theta) \left[ \phi \mathbf{D}_J + (1-\phi) \mathbf{D}_M \right] \quad (6.12)$$

One note of interest is the way the Eulerian continuity and momentum equations are solved. A solution of the equations as written above yields what is known as the hydrodynamic model. The term  $1/g$  can be set to zero if the user specifies a zero-inertia model. The effect of this is to cancel Eq. 6.9 and the  $\mathbf{Q}^2/\mathbf{A}g$  term in Eq. 6.10.

## THE NUMERICAL SOLUTION

The numerical procedure solves the Eulerian continuity and momentum equations using a fixed time step specified. The space increment is defined by the advance distances reached at the end of each time step. Referring to Fig. 6.3, the solution procedure computes the flow and cross-sectional area cell by cell beginning with the first triangular cell representing the initiation of irrigation and continuing until all the water has drained from the field following the cutoff of the inflow.

The Eulerian continuity and momentum equations are algebraic and nonlinear. As they are written for each cell along a specified time line, they become a system of such equations that can be solved simultaneously. This is an "implicit" approach. If we examine the problem of solving the equations at time  $\mathbf{t}_6$  as shown in Fig. 6.3, we see there are six cells. The known variables are all the  $\mathbf{Q}$  and  $\mathbf{A}$  values at time  $\mathbf{t}_5$  as well as the value for  $\delta \mathbf{x}_5$ . These values were

determined from the previous iteration of the solution procedure. At  $t_6$ , the unknown variables are  $Q$  and  $A$  at the cell boundaries and  $\delta x_6$ . There are therefore 12 unknown values. Writing the continuity and momentum equation for each cell gives 10 equations. Defining one boundary condition for left side of the first cell and the right side of the last cell gives the remaining two equations needed for the solution.

Solving the equations for  $t_6$  involves an advance front right side boundary condition. When the flow reaches the end of the field, this boundary condition is changed. Likewise when the flow is cutoff, the left side boundary condition is changed to simulate recession. Each of the solutions for these cases will be examined below.

### Initial Conditions


For the first time step in the solution, there is one triangular cell. Since  $(Q_R, A_R, Z_R)$ ,  $(Q_J, A_J, Z_J)$ , and  $(Q_M, A_M, Z_M)$  are zero, the continuity equation becomes:

$$\theta Q_L - \phi(A_L + Z_L) \frac{\delta x_1}{\delta t} = R_c \quad (6.13)$$

where  $R_c$  is the “residual” that will equal zero when the solution is completed. The unknowns in Eq. 6.13 are  $A_L$ , and  $\delta x_1$ . The value of  $Q_L$  is known from the left boundary condition (we assume we know what the inlet flow rate is per furrow or per unit width) and  $Z_L$  is computed directly from the total elapsed time. The momentum equation becomes:

$$\frac{1}{g} \phi Q_L \frac{\delta x_1}{\delta t} - \theta \left( P + \frac{Q^2}{Ag} \right)_L - \phi \theta (S_o A_L - D_L) \delta x_1 = R_m \quad (6.14)$$

Again,  $R_m$  is the residual in the momentum equation that will be zero when the solution is found.

Values for  $P$  and  $D$  in Eq. 6.14 are computed as follows (see  Ilker and Skogerboe (1987), p. 317):

$$P = \frac{1}{\chi_2 + 2} \left( \frac{\chi_2 + 1}{\chi_1} \right)^{\frac{1}{\chi_2 + 1}} A^{\frac{\chi_2 + 2}{\chi_1 + 1}} \quad (6.15)$$

in which:

$$\chi_2 = \frac{\log \left[ \frac{T_{max}}{T_{mid}} \right]}{\log 2} \quad (6.16)$$

and

$$\chi_1 = \frac{T_{max}}{Y_{max}^{\chi_2}} \quad (6.17)$$

(See Chapter 4 for definitions of  $T_{max}$ ,  $T_{mid}$ , and  $Y_{max}$ )

Likewise:

$$D = \frac{Q^2 n^2}{\rho_1 A^{\rho_2 - 1}} \quad (6.18)$$

(Again, see Chapter 4 for definition of  $n$ ,  $\rho_1$ , and  $\rho_2$ .)

One method for solving Eqs. 6.13 and 6.14 is the Newton-Raphson procedure. The procedure utilizes the first two terms of a Taylor Series in which the continuity and momentum equations are “linearized” as follows:

$$(R_c)_n = (R_c)_{n-1} + \left( \frac{\partial R_c}{\partial A_L} \right)_{n-1} \delta A_L + \left( \frac{\partial R_c}{\partial \delta x_1} \right)_{n-1} \delta \delta x_1 \approx 0 \quad (6.19)$$

and

$$(R_m)_n = (R_m)_{n-1} + \left( \frac{\partial R_m}{\partial A_L} \right)_{n-1} \delta A_L + \left( \frac{\partial R_m}{\partial \delta x_1} \right)_{n-1} \delta \delta x_1 \approx 0 \quad (6.20)$$

in which residuals in the continuity and momentum expressions improve from iteration  $\mathbf{n-1}$  to iteration  $\mathbf{n}$  until they approach zero. Also,

$$\delta A_L = (A_L)_n - (A_L)_{n-1} \quad (6.21)$$

$$\delta \delta x_1 = (\delta x_1)_n - (\delta x_1)_{n-1} \quad (6.22)$$

The values of  $\delta A_L$ , and  $\delta \delta x_1$ , are computed using Cramer’s Rule as follows:

$$\delta A_L = \frac{R_c \frac{\partial R_m}{\partial \delta x_1} - R_m \frac{\partial R_c}{\partial \delta x_1}}{\frac{\partial R_c}{\partial \delta x_1} \frac{\partial R_m}{\partial A_L} - \frac{\partial R_c}{\partial A_L} \frac{\partial R_m}{\partial \delta x_1}} \quad (6.23)$$

and

$$\delta \delta x_1 = \frac{R_m \frac{\partial R_c}{\partial A_L} - R_c \frac{\partial R_m}{\partial A_L}}{\frac{\partial R_c}{\partial \delta x_1} \frac{\partial R_m}{\partial A_L} - \frac{\partial R_c}{\partial A_L} \frac{\partial R_m}{\partial \delta x_1}} \quad (6.24)$$

where all expressions are evaluated with parameter values from the  $(\mathbf{n-1})$ th iteration.

The solution is iterative and begins by assuming initial values for  $\mathbf{A}_L$  and  $\delta \mathbf{x}_1$ . Values of  $\mathbf{R}_m$  and  $\mathbf{R}_c$  are computed from Eqs. 6.13 and 6.14. Values of  $\delta \mathbf{A}_L$  and  $\delta \delta \mathbf{x}_1$  are then computed from Eqs. 6.23 and 6.24. Revised values of  $\mathbf{A}_L$  and  $\delta \mathbf{x}_1$  are determined from Eq. 6.21 and 6.22. If these values are equal to the previous values, the solution has converged.

### Solutions During the Advance Phase

After the first time step and continuing through the advance phase, the numerical solution involves one or more rectangular cells and one triangular cell. Take for purposes of illustration the solution for  $\mathbf{t}_3$ . Utilizing the numbered outline of Fig. 6.3 rather than the  $\mathbf{R}$ ,  $\mathbf{L}$ ,  $\mathbf{J}$ , and  $\mathbf{M}$  notation, the linearized continuity and momentum equations for the rectangular cells are (all terms on the right side are evaluated at  $\mathbf{n-1}$  parameter values):



$$\left| \begin{array}{cccc|cccc|c|c}
\frac{\partial R_{c2}}{\partial A_1} & \frac{\partial R_{c2}}{\partial Q_1} & \frac{\partial R_{c2}}{\partial A_2} & \frac{\partial R_{c2}}{\partial Q_2} & & & & & \delta Q_1 & & -R_{c2}^{n-1} \\
\frac{\partial R_{m2}}{\partial A_1} & \frac{\partial R_{m2}}{\partial Q_1} & \frac{\partial R_{m2}}{\partial A_2} & \frac{\partial R_{m2}}{\partial Q_2} & & & & & \delta A_3 & = & -R_{m2}^{n-1} \\
& & & & \frac{\partial R_{c3}}{\partial A_2} & \frac{\partial R_{c3}}{\partial Q_2} & \frac{\partial R_{c3}}{\partial A_3} & \frac{\partial R_{c3}}{\partial \delta x_3} & \delta Q_2 & & -R_{c3}^{n-1} \\
& & & & \frac{\partial R_{m3}}{\partial A_2} & \frac{\partial R_{m3}}{\partial Q_2} & \frac{\partial R_{m3}}{\partial A_3} & \frac{\partial R_{m3}}{\partial \delta x_3} & \delta A_3 & & -R_{m3}^{n-1} \\
& & & & & & -\kappa_4 & 1 & \delta \delta x_3 & & \lambda_4
\end{array} \right|$$

**Figure. 6.4** The numerical solution matrix for the third time step during advance.

After all,  $\kappa$  and  $\lambda$  can take on any values from iteration to iteration. This assumption, combined with the banded nature of the solution matrix, leads to a two-pass numerical procedure for determining values for the unknowns  $\delta A_0 - \delta x_3$ . The first pass solves the following three recursive equations from  $j=1$  to  $j=3$ :

$$U_j = \frac{\frac{\partial R_{mj}}{\partial A_{j-1}} + \kappa_j \frac{\partial R_{mj}}{\partial Q_{j-1}}}{\frac{\partial R_{cj}}{\partial A_{j-1}} + \kappa_j \frac{\partial R_{cj}}{\partial Q_{j-1}}} \quad (6.29)$$

$$\kappa_{j+1} = \frac{U_j \frac{\partial R_{cj}}{\partial A_j} - \frac{\partial R_{mj}}{\partial A_j}}{\frac{\partial R_{mj}}{\partial Q_j} - U_j \frac{\partial R_{cj}}{\partial Q_j}} \quad (6.30)$$

$$\lambda_{j+1} = \frac{-R_{mj} - \frac{\partial R_{mj}}{\partial Q_{j-1}} \lambda_j + U_j \left( R_{cj} + \frac{\partial R_{cj}}{\partial Q_{j-1}} \lambda_j \right)}{\frac{\partial R_{mj}}{\partial Q_j} - U_j \frac{\partial R_{cj}}{\partial Q_j}} \quad (6.31)$$

Once the first pass has been completed, values of  $\kappa$  and  $\lambda$  have been determined for each cell. The second pass then proceeds from  $k=3$  to  $k=1$  by solving for  $\delta \delta x_3$  with Eq. 6.28 and the following recursively:

$$\delta A_{k-1} = \frac{-R_{ck} - \frac{\partial R_{ck}}{\partial Q_{k-1}} \lambda_k - \frac{\partial R_{ck}}{\partial A_k} \delta A_k - \frac{\partial R_{ck}}{\partial Q_k} \delta \delta x_3}{\frac{\partial R_{ck}}{\partial A_{k-1}} + \frac{\partial R_{ck}}{\partial Q_{k-1}} \kappa_k} \quad (\text{for } k = 3) \quad (6.32)$$

$$\delta A_{k-1} = \frac{-R_{ck} - \frac{\partial R_{ck}}{\partial Q_{k-1}} \lambda_k - \frac{\partial R_{ck}}{\partial A_k} \delta A_k - \frac{\partial R_{ck}}{\partial Q_k} \delta Q_k}{\frac{\partial R_{ck}}{\partial A_{k-1}} + \frac{\partial R_{ck}}{\partial Q_{k-1}} \kappa_k} \quad (\text{for } k \geq 1) \quad (6.33)$$

and then,

$$\delta Q_{k-1} = \kappa_k \delta A_{k-1} + \lambda_k \quad (6.34)$$

Finally, once all the values of  $\delta Q$ ,  $\delta A$ , and  $\delta \delta$  are determined, the solution is improved by computing revised values of area and flow at each cell boundary:

$$(A_j)_n = (A_j)_{n-1} + \delta A_j \quad (j = 0, 1, \text{and } 2) \quad (6.35)$$

$$(Q_j)_n = (Q_j)_{n-1} + \delta Q_j \quad (j = 1, 2) \quad (6.36)$$

and

$$(\delta x_3)_n = (\delta x_3)_{n-1} + \delta \delta x_3 \quad (6.37)$$

With the revised values of the area, flow, and advance distance -- variables determined by Eqs. 6.35 – 6.37, the continuity and momentum residuals can be recomputed. If their residuals are less than a tolerance of  $10^{-12}$  the solution is accepted. If any of the residuals for any of the cells exceeds this tolerance, the analysis proceeds to another iteration.

### Downstream Boundary Conditions at the End of the Advance Phase

The boundary condition that exists when the advance phase has been completed is typically either one where the water runs off the field or one in which the runoff is blocked by a dike. In both cases the values of  $\mathbf{M}$  and  $\mathbf{R}$  variables will no longer be zero as the cells will all be rectangular. A generalized boundary condition for this condition can be based on the expression:

$$Q_N = \alpha A_N^\beta \quad (6.38)$$

in which  $N$  is the number of the last cell in the profile and  $\alpha$  and  $\lambda$  are defined for a uniform flow, free draining end condition as:

$$\alpha = \frac{\sqrt{\rho_l S_0}}{n} \quad (6.39)$$

and

$$\beta = \frac{\rho_2}{2} \quad (6.40)$$

For the blocked-end condition,  $\alpha$  is set to zero. Using Eq. 6. 38, we can simplify Eqs. 6.34 and 6. 35 as follows:

$$\delta Q_R = \delta A_R \frac{dQ_R}{dA_R} = \delta A_R (\beta \alpha A_R^{\beta-1}) \quad (6.41)$$

which simplifies Eqs. 6.25 and 6.26 to:

$$(R_{cN})_n = (R_{cN})_{n-1} + \left( \frac{\partial R_{cN}}{\partial A_{N-1}} \right) \delta A_{N-1} + \left( \frac{\partial R_{cN}}{\partial Q_{N-1}} \right) \delta Q_{N-1} + \left( \frac{\partial R_{cN}}{\partial A_N} + \beta \alpha A_N^{\beta-1} \frac{\partial R_{cN}}{\partial Q_N} \right) \delta A_N \approx 0 \quad (6.42)$$

and

$$(R_{mN})_n = (R_{mN})_{n-1} + \left( \frac{\partial R_{mN}}{\partial A_{N-1}} \right) \delta A_{N-1} + \left( \frac{\partial R_{mN}}{\partial Q_{N-1}} \right) \delta Q_{N-1} + \left( \frac{\partial R_{mN}}{\partial A_N} + \beta \alpha A_N^{\beta-1} \frac{\partial R_{mN}}{\partial Q_N} \right) \delta A_N \approx 0 \quad (6.43)$$

The numerical procedure from this point follows the same course as discussed above for the advance phase.

---

## Chapter 7. The *SIRMOD III* Concept

---

### OVERVIEW

*SIRMOD III* is a comprehensive software package for simulating the hydraulics of surface irrigation systems at the field level, selecting a combination of sizing and operational parameters that maximize application efficiency and a two-point solution of the “inverse” problem allowing the computation of infiltration parameters from the input of advance data.

The simulation routines were developed over a number of years and coded into a MSDOS program named *SIRMOD*. The *SIRMOD III* programming is a 32 bit C++ revision of the original *SIRMOD* package. Numerical procedures used in the software are outlined in the text, “Surface Irrigation: Theory and Practice”<sup>11</sup>. The *SIRMOD III* software utilizes the evaluation procedures of Chapter 4, the design features of Chapter 5, and the numerical schemes outlined in Chapter 6.

### GETTING STARTED

The *SIRMOD III* software has been written for IBM compatible microcomputer systems utilizing Windows 95 and subsequent operating systems. The software is shipped as a self-extracting executable file on a CD ROM.

After receipt of the CD ROM, it is advisable to make a back-up copy. Then insert the *SIRMOD III* CD into the appropriate drive. From the Start Menu of the Windows screen, choose the Run command. After the Run dialog box appears, browse to the computer’s CD drive and select *SIRZIP.EXE* by clicking on the file name. Click the **OK** button to return to the Run dialog and then click **OK** again to extract the *SIRMOD III* program files. Another dialog box will appear asking where the software should be installed on the computer hard disk. After responding to this input, the software and related files will be extracted and stored. There are no special device drivers or installation procedures that require special attention. Simply extract the files included to the hard disk, develop any shortcut icons using the typical Windows procedures, and utilize the software.

There are sixteen files supplied with the distribution CD. These include the *SIRMODIII.EXE* file, five demonstration data files, eight infiltration text files, and two help files for the on-line help system. The demo files are named DEM1.CFG, DEM2.CFG, DEM3.CFG, DEM4.CFG, and DEM5.CFG as detailed in Table 7.1. The infiltration files are intake1.txt, intake2.txt, intake3.txt, intake4.txt, infilt1.txt, infilt2.txt, infilt3.txt, and infilt4.txt. Table 7.2 summarizes the characteristics of each of these files.

---

<sup>11</sup> Walker, W.R. and G.V. Skogerboe. 1987. Surface Irrigation: "Theory and Practice". Prentice-Hall Inc., Englewood Cliffs, New Jersey. 386 p.

**Table 7.1 SIRMOD III Demonstration Files.**

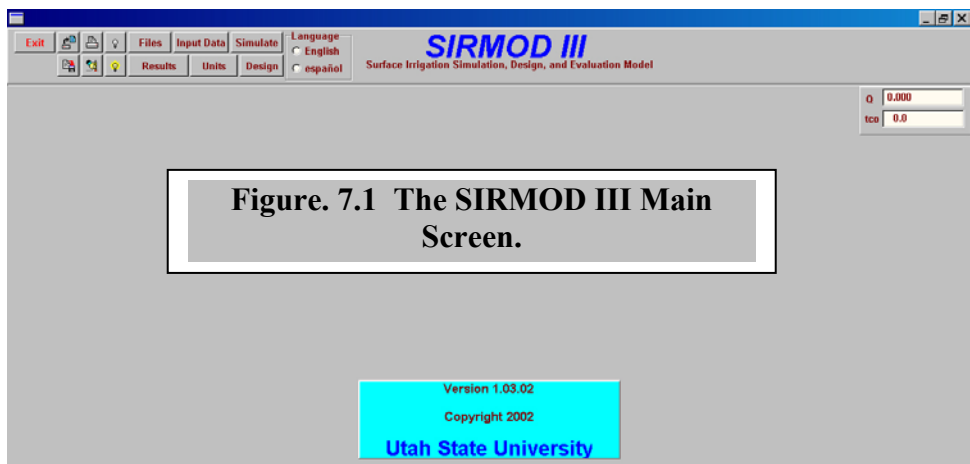
<i>File Name</i>	<i>Type of Surface Irrigation System</i>	<i>Flow Regime</i>	<i>Downstream Boundary Condition</i>
DEM1	Furrows	Continuous	Free-Draining
DEM2	Border	Continuous	Blocked-End
DEM3	Furrow	Continuous with Cutback	Free-Draining
DEM4	Furrow	Surged	Free-Draining
DEM5	Furrow	Surged with Cutback	Free-Draining

**Table 7.2. Description of SIRMOD III Infiltration Files.**

<i>File Name</i>	Description
Intake1.txt	First Irrigation, Continuous Flow, English Language
Intake2.txt	Later Irrigation, Continuous Flow, English Language
Intake3.txt	First Irrigation, Surge Flow, English Language
Intake4.txt	Later Irrigation, Surge Flow, English Language
Infilt1.txt	First Irrigation, Continuous Flow, Spanish Language
Infilt2.txt	Later Irrigation, Continuous Flow, Spanish Language
Infilt3.txt	First Irrigation, Surge Flow, Spanish Language
Infilt4.txt	Later Irrigation, Surge Flow, Spanish Language

**SPECIAL FEATURES**

The opening or main screen of **SIRMOD III** is shown in Fig. 7.1. Two special features of **SIRMOD III** need mention at the start of this manual. The first is the units the user wishes to see input and results expressed in, and the second is the language preference.



**Units**

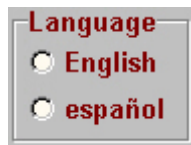
The input data and results of simulation, design, and evaluation can be displayed in metric or English units. This is a user selectable option



accessed via the **Units** button at the top of the main screen. Clicking on **Units** causes a drop-down menu to appear as shown below left.

There are three check boxes as shown for the user to select a preference. The selected system of units is stored with the input data file so each time the user loads the particular file those units will be displayed and used. Thus, the unit selection should be made before the final recording of the input data file. The default is the metric units. If no other system of units is selected, metric units will automatically be displayed and used. This menu will not disappear unless the user selects the **OK** button.

## Language



The user can choose between an English or Spanish language interface. This choice can be made by pressing the selecting one of the language radio buttons from the main menu.

As noted, any input data saved while a language choice is in effect will store the choice so the next time the data file is loaded, the selected language will automatically be displayed.

## Conventions

The *SIRMOD III* software relies on a number of buttons, checkboxes, radio buttons, etc. to execute its functions. A summary of these is shown below.

<u>SIRMOD III Button</u>	<u>Function</u>
	Exit <i>SIRMOD III</i> program
	Open existing configuration or output file
	Save configuration, output, or design file
	Printer configuration
	Pause simulation
	Resume simulation
	Erase Screen
	Close a screen and return to previous control
	Radio Button
	Checkbox

---

## Chapter 8. Running The SIRMOD III Software

---

The *SIRMOD III* software can be run from the **Run** command of the Windows Start menu, by double clicking on *SIRMODIII.EXE* from the Windows Explorer, or by clicking on a shortcut icon the user has created. In whatever case, the first program screen the user sees will be as shown in Fig. 8.1. Running *SIRMOD III* involves four tasks: (1) Data input; (2) File manipulation; (3) Simulation, Evaluation, and Design Analyses; and (4) Viewing, storing, and printing of results.

### DATA INPUT

Data input to the *SIRMOD III* software involves two activities: (1) defining the characteristics of the surface irrigation system under study; and (2) defining the model operational control parameters.

### Entering Field Characteristics

When **Field Characteristics** are accessed via the **Files** command bar button and then selecting the field characteristics button. A data entry screen is inserted on the main screen with three user-selectable tabs: (1) Field Geometry & Topography; (2) Infiltration Functions; and (3) Flow Cross-Section. Figure 8.1 shows the field characteristic data entry form opened to the Field Geometry/Topography page.

The screenshot shows a window titled "Field Data" with three tabs: "Flow Cross Section", "Infiltration Data", and "Field Topography/Geometry". The "Field Topography/Geometry" tab is active. The screen has a pink background and contains the following input fields and options:

- Manning Roughness Values**
  - First Irrigations: 0.04
  - Later Irrigations: 0.00
- Compound Slope Inputs**
  - First Slope: 0.000000
  - Second Slope: 0.000000
  - Third Slope: 0.000000
  - First Distance, m: 0.0
  - Second Distance, m: 0.0
- Field Length, m**: 0.0
- Field Width, m**: 0.00
- Field CrossSlope**: 0.00
- Row Spacing, m**: 1.00
- Downstream Boundary**
  - Free Draining
  - Blocked-End

A note at the bottom states: "The 'First Distance' is the distance from field inlet to the break in slope between 'First Slope' and 'Second Slope'. Similarly for the 'Second Distance'."

A "Close" button is located at the bottom right of the window.

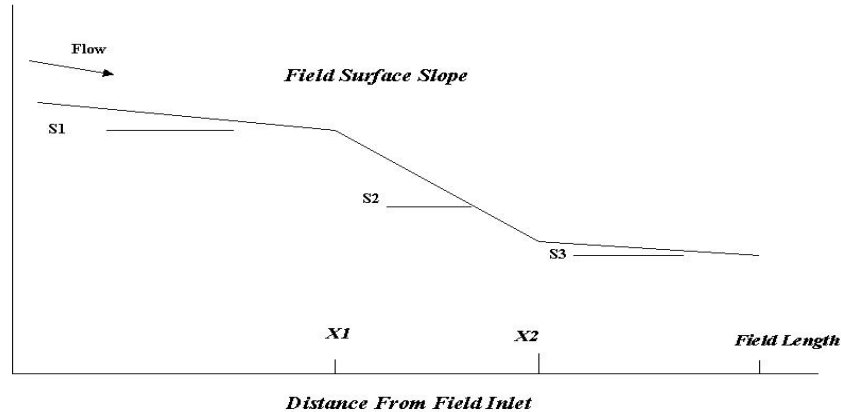
Figure 8. 1. Field Characteristics Input Screen.

## Field Geometry and Topography

The geometry and topography of the surface irrigated field is described by the following parameters:

- Manning roughness,  $n$ , for the first irrigations;
- Manning roughness,  $n$ , for later irrigations;
- Field length;
- Field width;
- Unit spacing for borders and basins, or furrow spacing;
- Field cross-slope;
- Three slope values in the direction of flow; and
- Two distance parameters associated with the three slopes.

The *SIRMOD III* software is capable of simulating fields with a compound slope as shown in Fig. 2.2. Three slopes are located in the field by two distance values as shown. When the field has only one slope, the same value needs to be entered for all three slopes and both distance values should be set to the field length. A field with two slopes can be defined by setting the first slope and distance value and then equating the remainder. Note that the design and evaluation procedures only allow one slope and thus if the field has a compound slope, an average value needs to be used in these computations.



**Figure 8.2. Schematic of Field Surface Configuration Parameters.**

There is one other input shown on Fig. 8.1 that should be noted. In the lower right-hand side the downstream boundary condition is selected using two radio buttons.

## Infiltration Functions

The tabbed notebook where infiltration functions are defined is shown in Fig. 8.3. This is the most critical component of the *SIRMOD III* software. Four individual infiltration functions are required: (1) a function for first conditions under continuous flow; (2) a function for later irrigations under continuous flow; (3) a function for first irrigations under surge flow; and (4) a function for later irrigations under surge flow. The user is referred to Chapters 3 and 4 for a

detailed discussion of how these parameters are defined and used in the software. Each infiltration function requires four parameters, **k**, **a**, **fo**, and **C**.

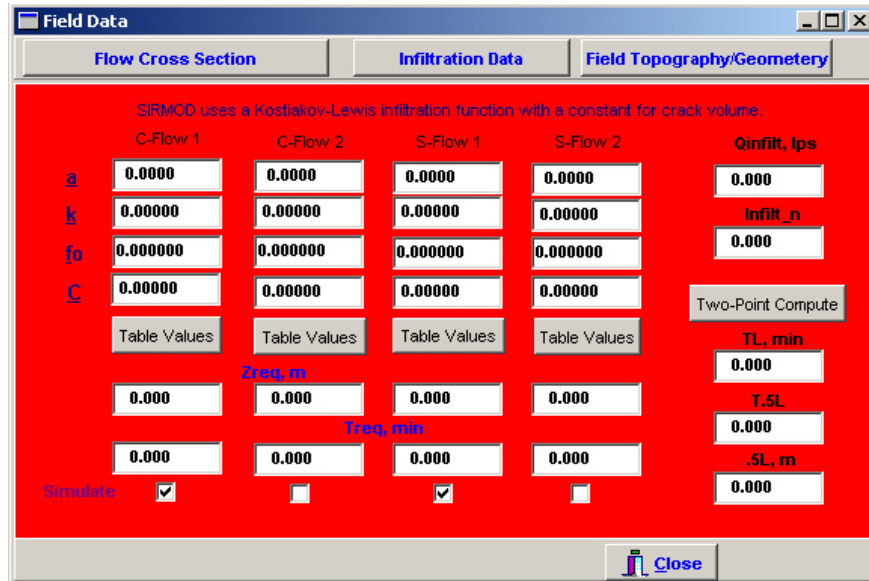


Figure 8.3. The Infiltration Input Screen.

Immediately below the four infiltration coefficients for the various surface irrigation regimes are four buttons labeled “Table Values”. These buttons access four default infiltration data sets as illustrated in Fig. 8.4. These can be selected by clicking on their radio buttons.

Figure 8.4. Table of Default Infiltration Coefficients.

Soil Index	Soil Type	a	k <i>m<sup>3</sup>/min<sup>a</sup></i>	fo <i>m<sup>3</sup>/min</i>	C <i>m<sup>3</sup></i>
<input type="radio"/>	0.01 HeavyClay	0.200	0.0044	0.000011	0.000000
<input type="radio"/>	0.05 Clay	0.258	0.0043	0.000022	0.000000
<input type="radio"/>	0.10 Clay	0.317	0.0038	0.000035	0.000000
<input type="radio"/>	0.15 LightClay	0.357	0.0036	0.000046	0.000000
<input type="radio"/>	0.20 ClayLoam	0.388	0.0035	0.000057	0.000000
<input type="radio"/>	0.25 ClayLoam	0.415	0.0034	0.000068	0.000000
<input type="radio"/>	0.30 ClayLoam	0.437	0.0033	0.000078	0.000000
<input type="radio"/>	0.35 Silty	0.457	0.0033	0.000088	0.000000
<input type="radio"/>	0.40 Silty	0.474	0.0032	0.000098	0.000000
<input type="radio"/>	0.45 SiltyLoam	0.490	0.0032	0.000107	0.000000
<input type="radio"/>	0.50 SiltyLoam	0.504	0.0032	0.000117	0.000000
<input type="radio"/>	0.60 SiltyLoam	0.529	0.0032	0.000136	0.000000
<input type="radio"/>	0.70 SiltyLoam	0.550	0.0032	0.000155	0.000000
<input type="radio"/>	0.80 SandyLoam	0.568	0.0032	0.000174	0.000000
<input type="radio"/>	0.90 SanyLoam	0.584	0.0032	0.000193	0.000000
<input type="radio"/>	1.00 SandyLoam	0.598	0.0033	0.000212	0.000000
<input type="radio"/>	1.50 Sandy	0.642	0.0034	0.000280	0.000000
<input type="radio"/>	2.00 Sandy	0.672	0.0036	0.000325	0.000000
<input type="radio"/>	4.00 Sandy	0.750	0.0042	0.000390	0.000000

The default data set is automatically loaded when the “Table Values” button is pressed. If the user has another data set, they can be displayed and selected by pressing the “Load From Data File” button. These data must be in a \*.txt format. Once a particular set of infiltration parameters has been selected, the user can click on the “OK” button and the values will be written to the appropriate locations on the data entry form.

Below the four “**Table Values**” buttons are four edit boxes for displaying the required infiltration depth,  $Z_{req}$ , and the associated intake opportunity time,  $\tau_{req}$ . The user can input data directly into either the  $Z_{req}$  or the  $\tau_{req}$  boxes and the program will compute the other parameter automatically.

To the right of the four infiltration functions are two parameters labeled  $Q_{infiltr}$  and **Infilt\_n**. The parameter  $Q_{infiltr}$  is the flow where the various infiltration parameters are referenced. If the user does not know this value, the discharge used in the simulation should be input in this edit box. In the current version of *SIRMOD III*, the **Infilt\_n** parameter is ignored. A future revision will activate this parameter which will allow the software to adjust infiltration parameters for varying flow rates.

The remaining button labeled “**Two-Point Compute**” and the three edit boxes in the lower right corner labeled  $T_L$ ,  $T_{.5L}$ , and  $.5L$  will be discussed below.

Finally, at the very bottom of the tabbed notebook, there are four check boxes with a side heading labeled “**Simulate**”. The user selects which infiltration condition will be used in a simulation executed by the software. One continuous and one surge flow infiltration function can be selected.

### Flow cross-section

Figure 8.5 shows the data entry form for the entry of cross-section data.

Top Width, m	Middle Width, m
0.000	0.000
Bottom Width, m	Maximum Depth, m
0.000	0.000

Rho1	Sigma1	Gamma1	Cmh
0.5709	0.3492	1.0572	0.0995
Rho2	Sigma2	Gamma2	Cch
2.8711	1.1099	0.3848	0.3773

Furrows  
 Borders/Basin  
 AltGeomet

Close

**Figure 8.5. Flow Geometry Input Parameters.**

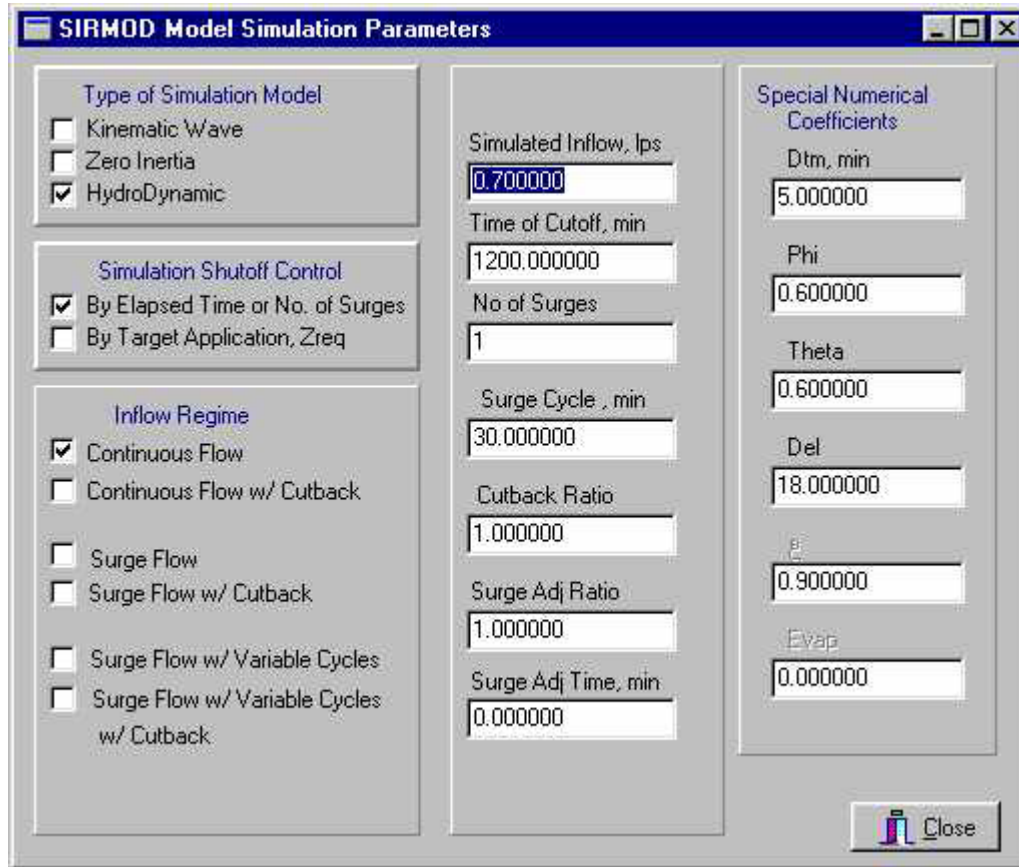
As a rule, the flow cross-section is defined and computed with four parameters, top width, middle width, base, and maximum depth. As these are entered eight parameters labeled Rho1, Rho2, Sigma1, Sigma2, Gamma1, Gamma2, Cch, and Cmh are automatically computed. They can be entered directly if desired but this is unusual. See Chapter 4 for a discussion of what these parameters are and how they are used.

Two check boxes in the lower right corner allow the user to select furrows or borders/basins for the type of surface irrigation system to be simulated, evaluated, or designed.

The *SIRMOD III* software automatically compute the hydraulic section parameters for various values of Rho1, Rho2, Sigma1, Sigma2, Gamma1, Gamma2, Cch, and Cmh. An alternative computation is available by pressing the **AltGeomet** button ( see Chapters 3 and 4)

**ENTERING MODEL CONTROL PARAMETERS**

**Model Parameters** The model control parameters are shown in Fig. 8.6 which appears when the drop-down option “**Model Parameters**” is selected.



**Figure 8.6. Model Configuration Parameters Input Screen.**

**Type of Simulation Model**

The *SIRMOD III* software includes three modeling choices: (1) kinematic-wave model; (2) zero-inertia model; and (3) hydrodynamic model. The default is the hydrodynamic model.

The user may choose a particular model for simulation by clicking their associated check boxes.

**Simulation Cutoff Control**

The termination of field inflow for the purposes of simulation is either by specifying a total inflow interval or by specifying a fixed depth of application. The interval will over-ride the depth control, so when using depth control the user should make the interval a large number.

## Inflow Regime

The *SIRMOD III* software will simulate both continuous and surge flow irrigation. There are two continuous and four surge flow regimes as shown in Fig. 8.6. The user may select one regime at a time for simulation by clicking on the respective check box.

The concepts of continuous and surge flow are fairly standard surface irrigation terms but are detailed by Walker and Skogerboe (1987) if the user needs more information regarding them. Cutback is a concept of having a high initial flow to complete the advance phase and a reduced flow thereafter. Both continuous and surged systems can operate with a cutback regime, although the only practical application of the concept is via surge flow.

Under a surge flow regime, there are two cycle options. The first is a fixed cycle time surge flow system and the second is a variable cycle time option. *SIRMOD III* offers two ways to vary the surge to surge cycle time. The first is by multiplying the first surge cycle by a user-specified fraction (See the “**Surge Adj. Ratio**” edit box). For example, if the first surge is 30 minutes and it is desirable to expand the surges by 10% each cycle, then the “**Surge Adj. Ratio**” can be set to 1.1. The second way of varying the surge cycle time is by adding a fixed amount of time to each surge via the “**Surge Adj Time**” parameter. For instance if one begins with a 60 minute cycle and wish to expand it 10 minutes each surge, then the “**Surge Adj Time**” parameter is set to 10. In both cases of variable cycle surge flow, the cycle times can be compressed by specifying a value less than 1.0 or a negative value “**Surge Adj. Ratio**”.

## Flow control parameters



There are seven flow control parameters: (1) **Simulated Inflow**; (2) **Time of Cutoff**; (3) **Number of Surges**; (4) **Surge Cycle**; (5) **Cutback Ratio**; (6) **Surge Adj. Ratio**; and (7) **Surge Adj. Time**.

## Special numerical coefficients


These coefficients are computed automatically by the software. For the typical simulation, the user need not alter them. They can be changed however should the user wish. Details of these parameters are given in Chapter 6.

## FILE MANIPULATION

The *SIRMOD III* software uses three types of files-- \*.cfg, \*.out, and \*.des. The \*.cfg files are the input and control data files. The software will not read any file without the cfg extension. Results from a simulation can be stored in a \*.out file and then opened later to plot or print. Results from the design analysis can be stored in a \*.des file for future reference.

The file open and save routines are accessed via buttons,  and . Files can be given other names via a “**Save As**” option under the **File** drop down menus. *SIRMOD III* uses standard dialog boxes for file manipulations.

## SIMULATION

Once the input and control data have been entered, the simulation is executed by clicking on the  button. The simulation screen will appear and the run-time plot of the advance and recession profiles will be shown as illustrated in Fig.8.7.

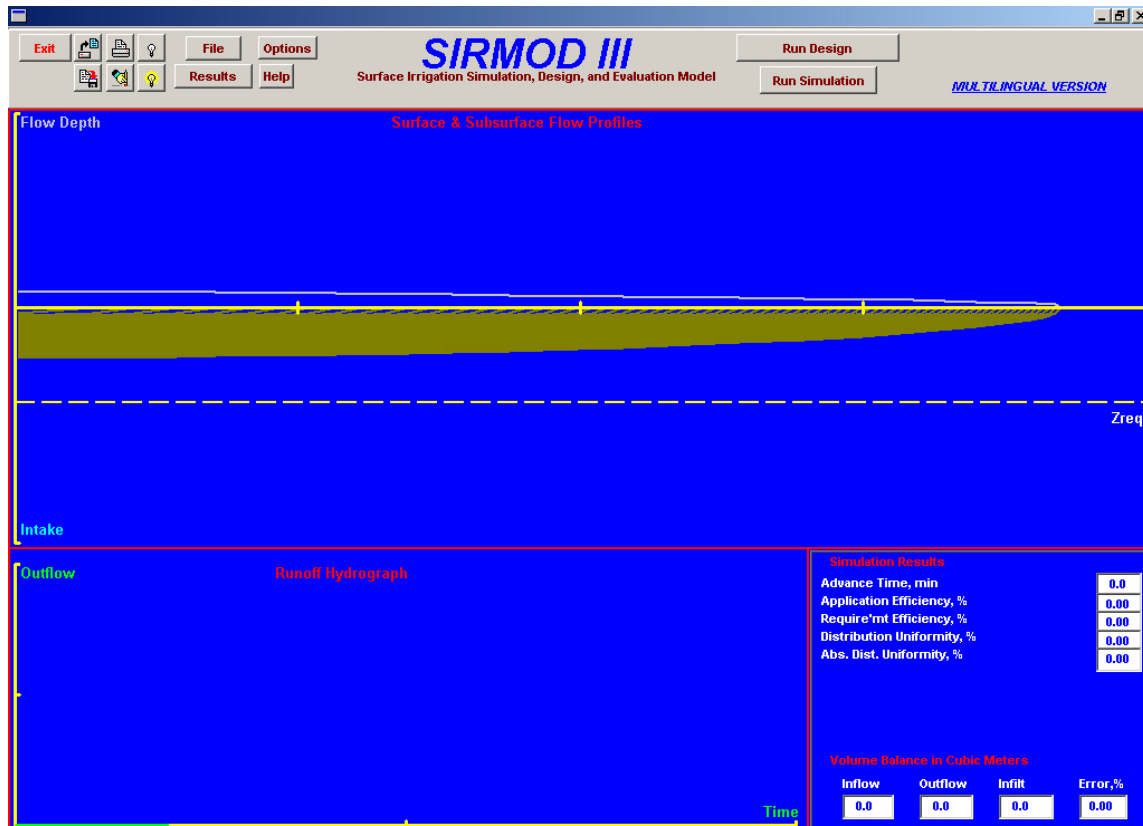
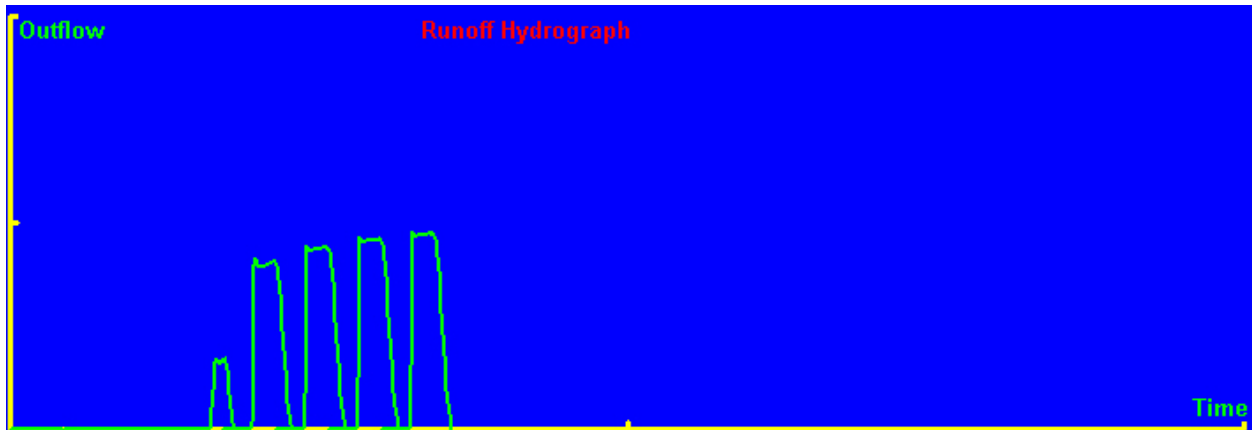


Figure. 8.7. Simulation Screen.

There are three important regions in the simulation screen. The first occupies the upper one-half of the screen and plots the surface and subsurface movements of water as the advance and recession trajectories are computed. The target or required depth of application is plotted as **Zreq** so that when an infiltrated depth exceeds this value the user can see the loss of irrigation water to deep percolation (The subsurface profile color changes as the depth exceeds **Zreq**). Details of the modeling theory for the *SIRM0D III* simulation of advance and trajectory are given in Chapter 6.

In the lower right side of the screen a summary of the simulated irrigation event will be published after the completion of recession. The uniformity and efficiency terms are defined in Chapters 3 and 4. The bottom four edit windows give a mass balance of the simulation, including an error term describing the computed differences between inflow, infiltration, and runoff (if the field is not diked). As a rule an error less than 5% is acceptable – most simulations will have errors of about 1%.

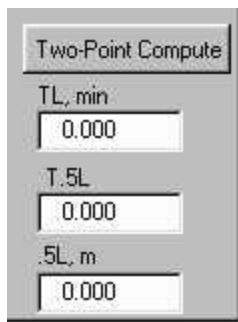
In the lower left side of the screen, a runoff hydrograph will be plotted for the cases where the downstream end of the field is not diked. Figure 8.8 illustrates one such hydrograph for a surge flow simulation. Note that neither the advance-recession nor the runoff hydrograph are intended to be quantitative, as no units are included in the plot. These details are presented in the plotted and printed output from the model.



**Figure 8.8. Runoff Hydrograph Plot.**

***EVALUATION***

The evaluation of infiltration coefficients from advance data is initiated by pressing the **Two-Point Compute** button on the **Infiltration Data** input panel. The figure below shows that region of the data input panel.



The evaluation procedure only applies to the two continuous flow functions in this version of the software. The procedure will be applied to the continuous flow infiltration function identified by the check box at the bottom of the panel.

Inputs to the evaluation procedure are the **Qinfilt** value from the box above, values for **f<sub>o</sub>** and **C** in the infiltration function itself, the time of advance, time of one-half field advance, and the one-half length, shown as the edit boxes to the below the **Two-Point Compute** button.

The two-point procedure will compute and revise the values of **a** and **k** in the continuous infiltration function that is checked.

***DESIGN***

The design algorithms are initiated by clicking on the **Run Design** button on the main command bar of the main screen. This will introduce the design screen shown as Fig. 8.9.



Figure 8.9. The SIRMOD III Design Screen.

### Volume Balance Design

The design system requires all of the input from the field characteristics and model parameter data entry pannels. Then clicking the **Volume Balance Design** button will execute the volume balance design procedures outlined in Section VI for the system configuration checked in the boxes of the upper left part of the screen:



Designs are computed for both first and later irrigation conditions. The designs can be simulated by pressing either or both of the **Simulate 1st Design** and the **Simulate 2nd Design** buttons on the command bar. These buttons initiate the simulation routines with the results shown in the edit boxes below. However the actual simulation screen does not appear. If the user would like to see the advance and recession trajectories displayed, it is necessary to return to the main screen and execute

the simulation by pressing the **Run Simulation** button.

There are four regions of the design screen that require special attention. These are: (1) the edit boxes for design slope and maximum velocity; (2) the required infiltration edit boxes; (3) the field layout; and (4) the total available flow and time boxes. All of these involve situating the design to the field conditions.

## Field Adaptation

It is important to note that the design must satisfy constraints on how much water is available and how long the supply will be available. The flow required and its duration depend on the design variables like unit or furrow flows, cutoff times, target depths of application, and application efficiency. Reconciling these parameters with the actual field condition may require subdividing the field or changing some of the input variables to the design algorithms.

### *Design Slope and Maximum Velocity*

The user will need to supply the design algorithms with value of design slope and maximum allowable non-erosive flow velocity. These inputs occur in the label boxes shown



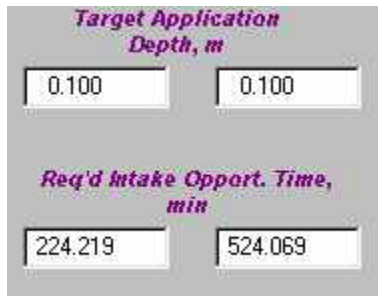
A screenshot of a software interface showing two input fields. The first field is labeled "Design Slope" and contains the value "0.0005". The second field is labeled "Max Vel. m/min" and contains the value "12.000".

here: . The default value of design slope is the principal slope entered into the field characteristics files but can be changed here to determine a better value if necessary.

Changing the value of the design slope implies re-leveling the field surface. As a rule this should be a last resort design parameter as it substantially increases the cost of the surface irrigation system and can only really be justified by water, labor, and/or energy savings.

Increasing or decreasing the maximum velocity may impact the application efficiency and thereby the necessary duration of the irrigation. As a rule, the higher the velocity the higher the application efficiency can be, but at the same time the higher the erosion risk.

### *Required Depth of Application*

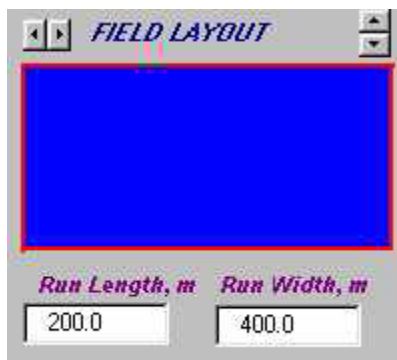


A screenshot of a software interface showing two rows of input fields. The first row is labeled "Target Application Depth, m" and has two fields, both containing "0.100". The second row is labeled "Req'd Intake Opport. Time, min" and has two fields, containing "224.219" and "524.069".



Each irrigation is designed to apply a depth of water to the soil that replaces the water already extracted by the crop. These values can be entered with the field characteristics tabbed notebook (default) or modified in the design screen to the left. The user can enter either required depth or intake opportunity time and the other variable will be automatically computed.

Increasing the required depth of application will generally improve application efficiency but also increase the duration of the irrigation. Large depths imply longer periods between irrigations and thus increase the risk of crop stress.

### *Field Layout*



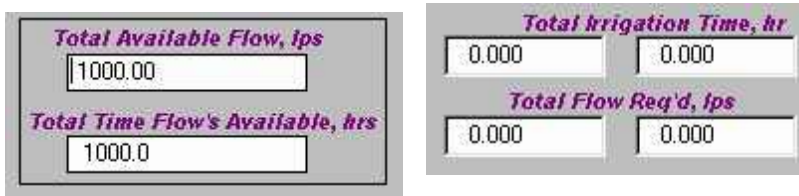
A screenshot of a software interface titled "FIELD LAYOUT". It features a large blue rectangular area representing the field. Below this area are two input fields: "Run Length, m" with the value "200.0" and "Run Width, m" with the value "400.0". There are also navigation arrows on the top and right sides of the blue area.

In the lower left side of the screen is a display box with a heading of Field Layout (see figure below). Below the display box are two edit boxes showing the field length and width. Default values come from the field characteristics input. In the course of design it may be necessary or desirable to evaluate the field design by subdividing the field. This can be accomplished by the two UpDown controls,   on both of the upper sides of the display box. By clicking the UpDown controls, the field can be subdivided in both the length and width directions.

Without field subdivision, it is assumed the entire field

will be irrigated at the same time. This may require a flow from the supply system that exceeds the maximum value allowed. Subdividing the field width allows the field to be irrigated in sets with an optimal unit flow rate without violating the total inflow constraint. Subdividing the field in any direction will increase the duration of the total irrigation and thus this must be watched. Whenever either the total supply rate or the duration the supply is available is exceeded, a warning message is displayed on the screen.

The total supply and supply time available are input parameters in two boxes above the field layout display box. The actual supply and duration a design requires is shown in two other boxes as illustrated below. The user can monitor these regions of the screen to see how various design parameters are impacting the supply constraints.



### Output

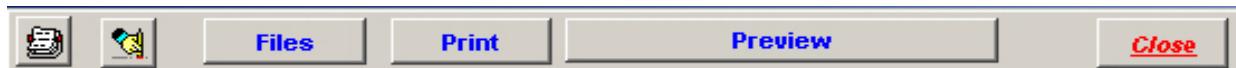


The *SIRMOD III* software includes both printed and graphical display output capabilities. The graphical displays cannot be directly printed in this version. The output is accessed from the main

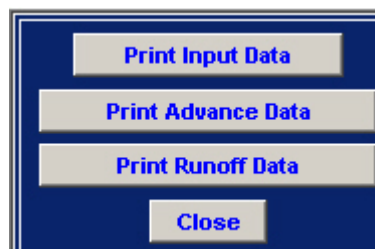


screen drop-down menus. By clicking on the **Results** heading, a drop-down menu appears giving the user a choice between printed and plotted results. Selecting either one will display the pertinent screen from which the user can select various data to display or print.

### Printed Output

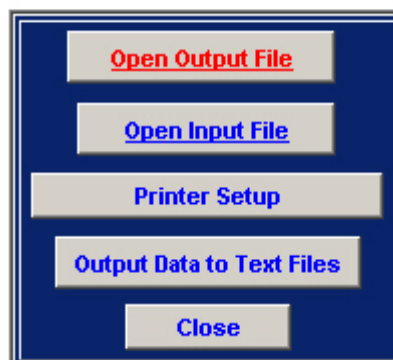


The command bar for the print out screen is shown above. Printed output can be either printed or previewed with the appropriate selection. Each selection allows the user to choose one of three sets of data: (1) the input parameter values; (2) the advance/recession/infiltration profiles; and/or (3) the runoff hydrographs. If the user is sending these printouts to a local printer, it should be selected and routines as there is no



setup prior to using these printer setup accessible

It is also possible to

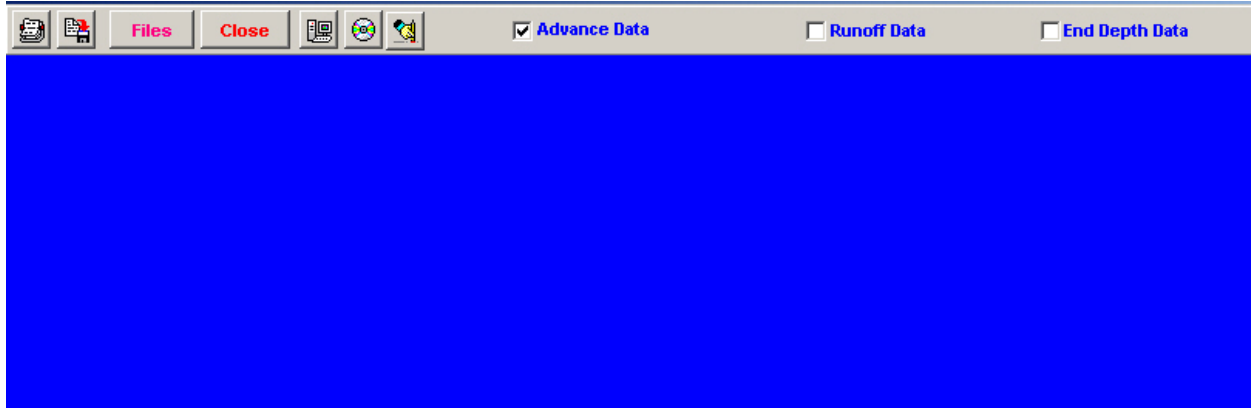


send the data to a disk as

text files. These options are accessed from the **Files** drop-down menu along with option to load input and output files as well as to set up the printer.

### ***Plotted Output***

Clicking on the **Plotted Results** option under the **Results** menu reveals the plotting screen shown in Fig. 8.10.





**Figure 8.10. Graphical Output Screen.**

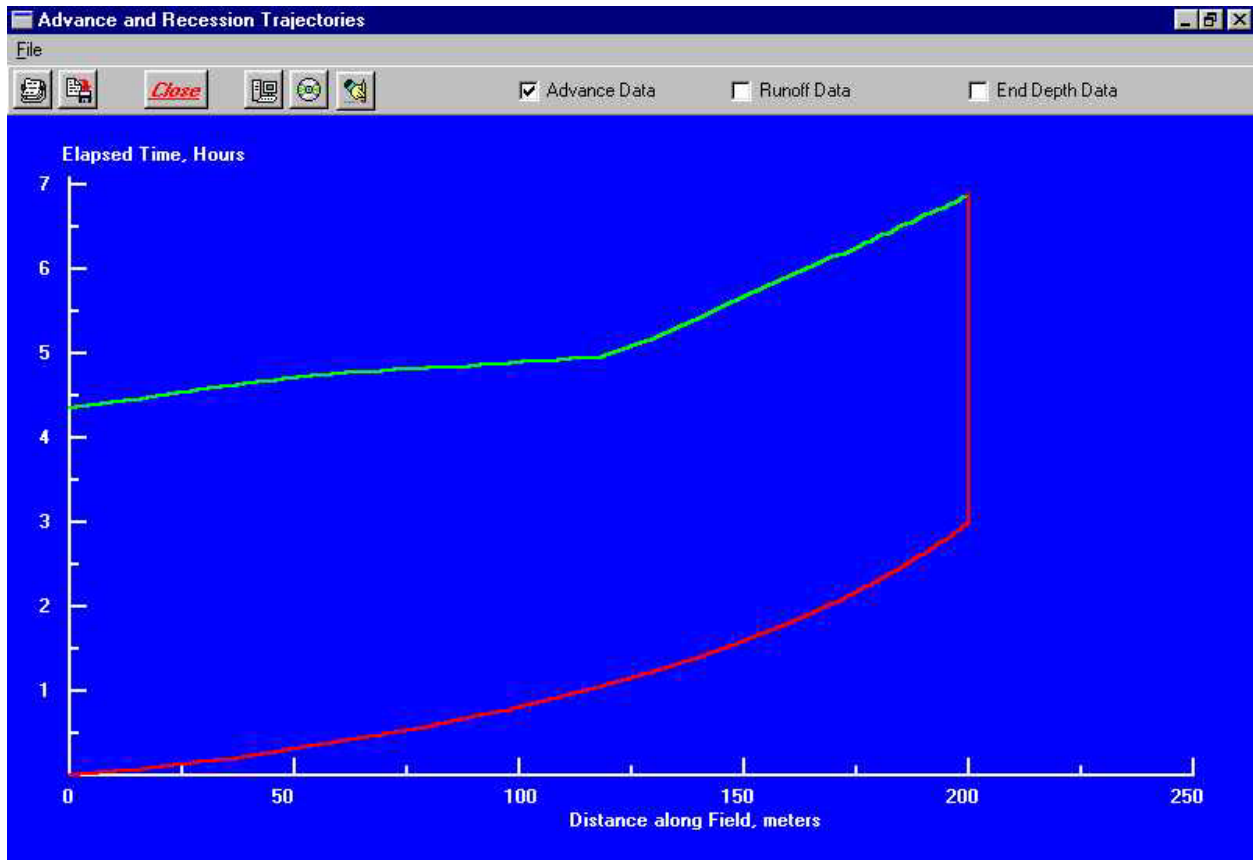
Three sets of data can be plotted by checking the appropriate box as shown below:



Figure 8.11 shows the advance-recession trajectory from a simulation of a blocked-end border.

At times the user may wish to plot data in computer memory, , or from a stored file,  that can be loaded and plotted on the same graph as the memory data to show





**Figure 8.11. An Advance- Recession Trajectory in the Graphical Output Screen.**

a comparison of two simulations. Accessing the Files button shows the following drop-down menu form which data can be stored or loaded. As noted earlier, these plots cannot be printed directly in this version of *SIRMOD III*.

---

## Chapter 9. Surge Flow<sup>12</sup>

---

### CONCEPTUAL DEVELOPMENT

Stringham and Keller (1979) introduced the concept of surge flow in the 1979 Irrigation and Drainage Specialty Conference of the American Society of Civil Engineers. The report was a preliminary discussion of a promising automating technique for achieving cutback in furrow irrigation. Their basic premise was stated as follows:

“Previous attempts to develop automatic cutback irrigation systems have concentrated on reducing the steady state stream size. However, simple automatic irrigation valves can only turn water on or off, but not half on or half off. Therefore, we concluded that it would be simpler to cycle the valves to reduce the average flow rate instead of partially closing the valves.”

A revised version of the system described by Stringham and Keller (1979) is shown here. Pneumatic valves were modified for low pressure by replacing the diaphragm and then were installed on a PVC pipeline. Banks of valves were operated in coordination with a microprocessor-based controller to achieve a cycling sequence ranging from a few seconds to several hours. To test the equipment, a small unit was set up on 12 furrows, 600



ft long. The furrows were divided into three sets each having a valve discharge of 13 gal/min. The first bank was allowed to run continuously until completion of the advance phase. The second was cycled approximately 8 seconds on and off to achieve an average flow rate in the furrow of 6.3 gal/min. The third set was cycled approximately 16 seconds on and 8 seconds off, yielding an average furrow flow of 8.6 gal/min. In addition to

---

<sup>12</sup> Taken from Walker and Skogerboe (1987), and Walker (1989).

observing the operation of the system, limited field data were collected to record the advance rate.

In retrospect, the interpretation of the field data demonstrated considerable insight. The advance rates under the 16-8 cycling were faster than for continuous flow. The continuous flow, however, advanced more rapidly than the 8-8 cycled furrows. The authors stated: "If subsequent tests verify this phenomenon [faster advance rate due to cycling], the implications are extremely interesting in terms of distribution uniformity along furrows and runoff rates." They were speculating that cycling the inflows somehow created an advantage not theretofore understood – a conclusion that has since been proven with remarkable clarity.

Actually, the surge flow phenomenon had been observed by irrigators for more than two decades prior to the initial research. Many irrigators found it impossible to complete the advance phase of an irrigation following a major cultivation because of the high intake rate. They discovered that by diverting the flow to another set for a few hours or a day when the advance rate stopped, and then returning the flow to the partially wetted field later, the advance phase could be completed.

Today, surge flow is a management practice that can be applied to many surface-irrigated conditions. It can be used either to "cut back" the inflow at the completion of advance and minimize tailwater, and/or to accelerate the advance phase on problem soils. A large number of researchers, primarily in the western United States have investigated this practice.

These early field evaluations have now been supplemented by numerous other tests under a wide range of field conditions (Walker et al., 1982; Podmore and Duke, 1982; and various others reporting only to the W163 project). The results have generally been mixed and few as significant as those at USU in 1979 and 1980. The following conclusions can be derived from field studies to date:

1. Intermittent flow over the field surface significantly reduces intake. The effect of surging is probably associated with the accelerated development of a thin surface seal comprised of very fine soil particles created by the water movement. During the drainage period, the buildup of negative pressure consolidates this thin seal, thereby reducing the permeability.
2. By reducing infiltration rates, it becomes easier to complete the advance phase. Advance rates are very sensitive to the discharge, so that as surge flow reduces infiltration, the hydraulic performance of the system improves.
3. The surge flow regime reduces the temporal and spatial variability exhibited in advance rates. Elliott and Walker (1982) showed that variations in the field's basic intake rate were often statistically insignificant. The surge flow effect in this regard may therefore be attributed to the lower time required to reach a steady or basic intake rate.

### ***DEVELOPMENT OF SURGE FLOW SIMULATION MODELS***

In reviewing the testing at the end of the 1980 irrigation season, a number of intriguing questions emerged, such as the effect in other soils and surface irrigation systems, the management of cycle times and ratios to maximize uniformity and efficiency, and the structural elements needed to implement surge flow practices. Further, if the concept proved effective and feasible for a broad range of conditions, a major issue, as how to design a surge flow surface irrigation system. As a result, two decisions were set in motion. The first was to expand the

scope of surge flow research by promoting regional research coordination. This led to the formation of the Agricultural Experiment Station- USDA Regional Project W163, "Surge Flow Surface Irrigation." Most of the research reported since 1982 falls under this project. The second decision, limited to Utah State University, was to redirect research efforts toward the development of computer-based simulation models of surged operations.

The modeling of surge flow systems was divided into three phases: (1) field data collection for model verification; (2) model formulation and debugging; and (3) model analysis of operational factors.

### **Verification Data**

A review of the hydraulics of surface irrigation, such as in Chapter 6, indicates that the data necessary to evaluate an irrigation event would include an inflow-outflow hydrograph, advance and recession trajectories, flow geometry, field slope, length, and roughness and infiltration characteristics. These conditions require a maximum of 16 individual parameters whose variations can vary by as much as an order of magnitude. Thus, developing a comprehensive understanding of their interrelationships would require an enormously expensive and time-consuming field investigation program.

The alternative to research through field evaluation is through theoretical study. Mathematical relationships are formulated and then verified by selective comparison with field observations. Field data collection is still required, but less often and more carefully determined. If it can be shown that a mathematical model accurately simulates a broad range of field data, it can be assumed that it will also simulate any combination of data falling within the limits. Modeling is relatively inexpensive and has the additional advantage that once verified, a multitude of analyses can be performed to investigate changes in both design and operational conditions.

Two field studies were conducted in 1981 to generate data for model testing. The first was on a field near Flowell, Utah, in which a conversion from a sideroll sprinkle to a furrow irrigation system was being made to allow corn production. The field was about 360 m long with a slope of 0.8%. The soil was a sandy loam. Upon irrigating the furrows the first time, the irrigator was not able to complete the advance phase without resorting to repeated "bumping," even though the individual furrow discharges ranged as high as 2.5 to 3.0 liters/s. Utah State University was invited to test the surge flow technique on this field in the hopes that it might increase uniformity and efficiency enough to compete with a center-pivot sprinkle system being considered as an option. The water supply for the entire farm was derived from a large well. A 75-hp pump was used to lift the water into a buried pipe network feeding the surface irrigation system via 10-in. gated pipe. To utilize the sprinkle systems, a 50-hp pump was used to pressurize the flow.

The second site was about 5 miles south of Kimberly, Idaho, and was selected in cooperation with researchers at the Snake River Conservation Research Center, USDA. The field was topographically similar to the Flowell field, but the soil was a silty-clay loam. Again, the irrigator had difficulty completing the advance phase and had practiced bumping. The field itself had just been plowed-out of many years of alfalfa production and the soil structure was very stable. At the time of the study, a first irrigation was being applied to a bean crop on part of the field and corn crop on the other. The water supply for the farm was derived from a gravity-flow mutual ditch association acquiring water from the Snake River.

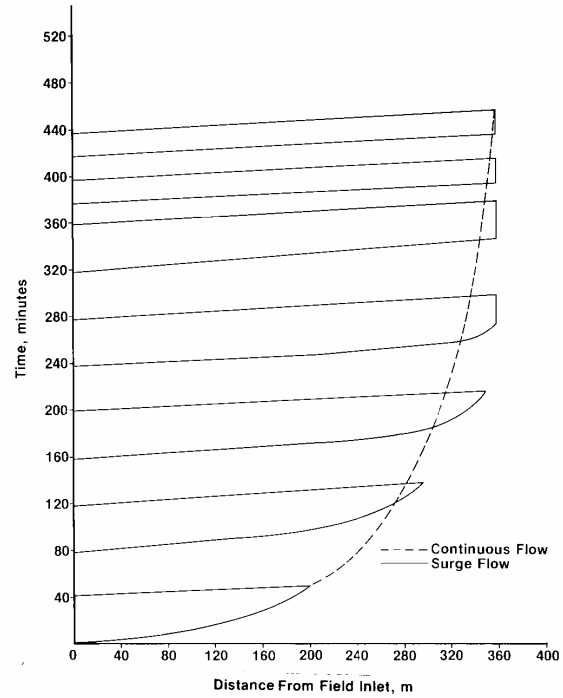
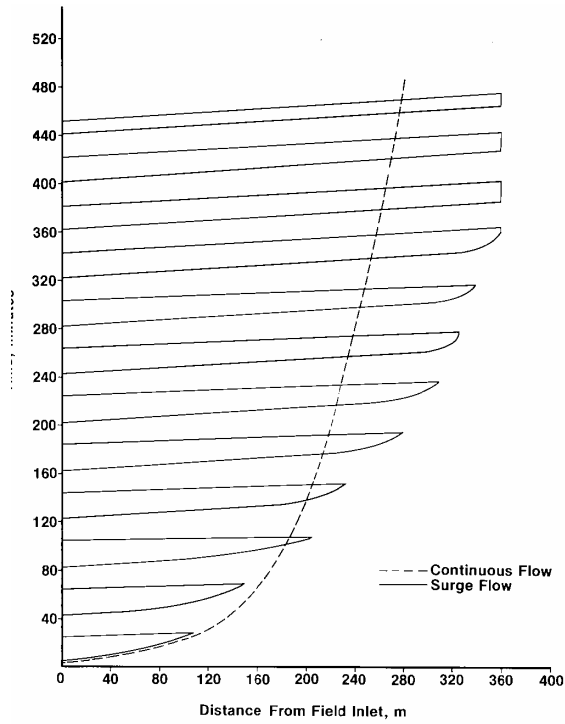
The testing at each site involved several stages. The irrigator was asked about the discharge being used so that the surge flow trials could use the same instantaneous flows. The field was staked along the furrow lengths in 30-m intervals and the slope surveyed. Small cutthroat and trapezoidal flumes were installed at the inlet and outlet of the test furrows to record the inflow-outflow hydrograph. The individual furrow cross sections before and after irrigation were measured with the profilometer described in Chapter 4, and independent infiltration measurements were made with the recirculating infiltrometer, also described in Chapter 4. The comparison of surge and continuous flow irrigation regimes involved a cycle time of 20 to 120 min and a cycle ratio of 0.5. Replications were divided into wheel compacted and noncompact furrows, and a range of discharges was utilized. The advance and recession trajectories of each surge and continuous flow treatment were observed and recorded.

Figures 9.6 and 9.7 are two examples of the wheel and nonwheel results at the Flowell site. The solid lines represent the surge by surge advance-recession trajectories, and the superimposed dashed line is the advance trajectory of a continuous flow treatment having similar conditions. The problem of furrow irrigation at the site is most evident in Fig. 9.6. The flow simply stops advancing at about 280 m. By surging with 40-min cycles, the advance phase was completed in nine surges. Using the field discharge of 2liters/s for 180 min yielded an average applied depth of 6 cm per furrow, or since the irrigated furrow spacing was 1.5 m, an average field depth of 4 cm. During the same elapsed time, the continuous flow furrow received twice as much water and only wetted 78% of the furrow. The average depth applied was 10 cm, 2<sup>1</sup>/<sub>2</sub> times as much as the surged furrows.

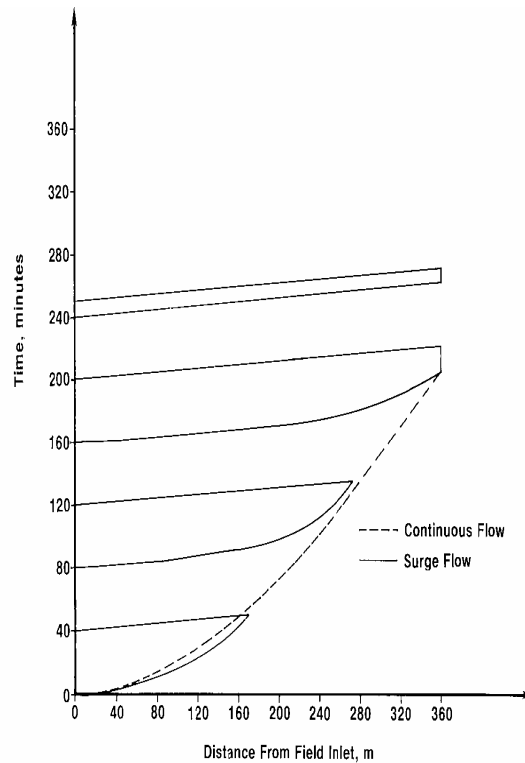
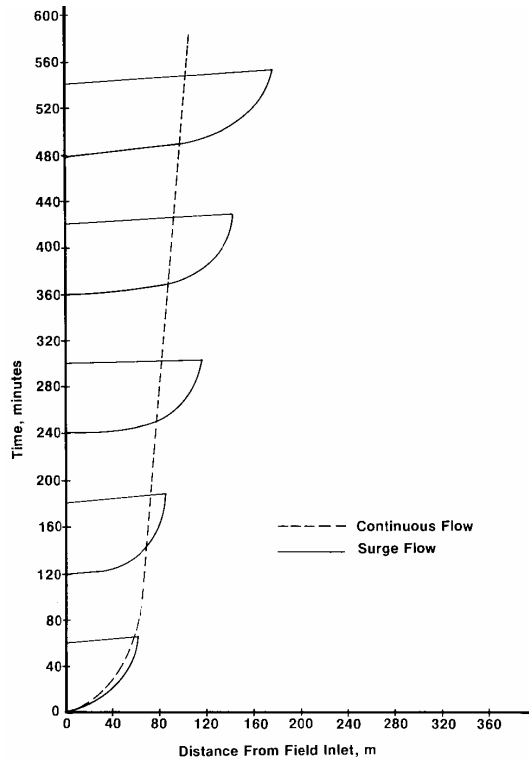
Figures 9.8 and 9.9 illustrate two of the test results gathered from Kimberly. In Fig. 9.8, a 1.0- liter/s flow was applied to noncompact furrows. Again the solid lines and dashed lines represent surged and continuous flow measurements. However, in this case, the furrow inflow was not sufficient, and although the surging treatment was creating the desired effect, it did not result in a solution to the problem. Figure 9.9 on the other hand illustrates in the case of a wheel compacted furrow the more typical result of surging in tighter soils. A 40-min surged flow completed the advance time in about the same interval as the continuous flow, but with one-half the total volume applied.

There have been many surge and continuous flow comparisons (Izuno et al., 1985; Evans et al., 1985; Wallender, 1985; Blair and Smerdon, 1985; and others who have reported only to the W163 project at the time of this book). The results confirm the results reported above to varying degrees. In a small number of tests, the surging has been less effective. Examining all the results in a qualitative manner has led to the observation that soil aggregate stability and texture have a significant effect on the surging effectiveness. In relatively stable sandy loam soils, infiltration rates decrease at much slower rates than in unstable clay loam soils. Part of the decrease in infiltration rates is due to the restructuring of the furrow surface due to the water's mechanical breakdown of the soil aggregates. The primary effect of surge flow is to consolidate the disturbed soil surface during the drainage period. Since the less stable soils exhibit more rapid change in surface permeability, the effect of surge flow is less than in sandy soil.

A summary of the field measurements at Flowell and Kimberly for selected tests is given in Tables 9.1 and 9.2. These data were used to verify the hydraulic models described in Chapters 14 to 16 for both continuous and surge flow conditions.



**Figure 9.6 Advance and recession trajectories**  
**Figure 9.7 Comparison of advance rates**  
**for continuous and surged nonwheel furrows**  
**under continuous and surged wheel**  
**at Flowell, Utah.**  
**furrows at Flowell, Utah.**



**Figure 9.8 Continuous and surged flow advance and recession for nonwheel furrows near Kimberly, Idaho.**

**Figure 9.9 Wheel furrow advance trajectories for continuous and surged furrows near Kimberly, Idaho.**

**Model Modification and Verification**

The first successful effort to modify one of the hydraulic models for surge flow simulation was reported by Walker and Lee (1981). This report described a kinematic-wave model which used zero-inertia-type first-order integration continuity equation. Since that time, a revised kinematic-wave model has been verified (Walker and Humpherys, 1983). Essafi (1983) formulated a recursive volume balance model and successfully verified it for surge flow conditions. Oweis (1983) expanded the zero-inertia model to surge flow conditions, and did the same for a fully hydrodynamic model. Thus four levels of surface irrigation hydraulics have been developed: (1) the volume balance model, (2) the kinematic wave model, (3) the zero-inertia model, and (4) the hydrodynamic model. The volume balance and kinematic-wave models are general for furrow irrigation, capable of simulating both continuous and surged flow systems accurately, but limited to sloped fields. The lower limit on slope depends somewhat on the infiltration rates but is on the order of 0.1% and less. Both models determine the distribution of infiltrated water and runoff hydrographs.

**TABLE 9.1 FURROW MODELING INPUT DATA FOR CONTINUOUS FLOW**

Model input parameters	Flowell nonwheel furrow	Flowell wheel furrow	Kimberly nonwheel furrow	Kimberly wheel furrow
Soil type	Sandy loam	Sandy loam	Silty-clay loam	Silty-clay loam
Inflow (liters/s)	2.0	2.0	0.8	1.5
Field length (m)	250	360	360	360
Field slope (m/m)	0.008	0.008	0.0104	0.0104
Manning's n	0.04	0.04	0.04	0.04
Hydraulic section parameters				
$\rho_1$	0.3269	0.3269	0.6644	0.6644
$\rho_2$	2.734	2.734	2.8787	2.8787
Furrow geometry parameters				
$\sigma_1$	0.782	0.782	0.962	0.962
$\sigma_2$	0.536	0.536	0.6046	0.6046

Time of cutoff (min)	350	400	400	200
Kostiakov-Lewis infiltration function parameters				
$k$ (m <sup>3</sup> /m/min)	0.002169	0.0028	0.00701	0.00884
$a$	0.673	0.534	0.533	0.212
$f_0$ (m <sup>3</sup> /m/min)	0.000222	0.00022	0.00017	0.00017

Source: After Walker and Humpherys (1983)

**TABLE 9.2 FURROW MODELING INPUT DATA FOR SURGED FLOW**

Input parameters	Flowell nonwheel furrow	Flowen wheel furrow	Kimberly nonwheel furrow	Kimberly wheel furrow
Soil type	Sandy loam	Sandy loam	Silty-clay loam	Silty-clay loam
Inflow (liters/s)	2.0	2.0	0.8	1.5
Field length (m)	360	360	360	360
Field slope (m/m)	0.008	0.008	0.0104	0.0104
Manning's $n$	0.04	0.04	0.04	0.04
Hydraulic section parameters				
$\rho_1$	0.3269	0.3269	0.6644	0.6644
$\rho_2$	2.734	2.734	2.8787	2.8787
Furrow geometry parameters				
$\sigma_1$	0.782	0.782	0.962	0.962
$\sigma_2$	0.536	0.536	0.6046	0.6046
Continuous flow intake parameters				
$k$ (m <sup>3</sup> /m/min)	0.002169	0.00280	0.00701	0.00884
$a$	0.673	0.534	0.533	0.212
$f_0$ (m <sup>3</sup> /m/min)	0.000222	0.000222	0.00017	0.00017
Surge flow intake parameters				
$k$ (m <sup>3</sup> /m/min)	0.003561	0.00459	0.00494	0.00625
$a$	0.322	0.356	0.493	0.196
$f_0$ (m <sup>3</sup> /m/min)	0.00018	0.00018	0.00012	0.00012

Cycle time (min)	40	80	80, 120	80
Cycle ratio	0.5	0.5	0.5	0.5

*Source:* After Walker and Humpherys (1983).

The zero-inertia and hydrodynamic models are more general in that they are not limited by furrow systems or by slope. Thus these models can simulate continuous and surge flow practices in furrow, border, and basin irrigation systems.

**Surge flow modifications.** Each of the four models incorporates a common strategy for computing infiltration. Field observations, particularly those by Malano (1982) and Walker et al. (1982), indicated that the cycled wetting of soil can be represented by basically two independent functions. However, it appeared that neither function adequately handled the second wetting since the, wetted perimeter changes significantly between the first and third surges.

In a furrow section where the discharge is relatively constant from surge to surge, infiltration can be evaluated by two Kostiakov-Lewis equations:

$$Z_c = k\tau^a + f_o\tau \quad (9.1)$$

and

$$Z_s = k'\tau^{a'} + f_o'\tau \quad (9.2)$$

where  $Z_c$  and  $Z_s$  are the infiltrated volumes per unit of furrow length ( $L^2$ ) for dry, continuous flow conditions and wet, intermittent flow conditions, respectively. The parameters  $k$ ,  $k'$ ,  $a$ ,  $a'$ ,  $f_o$ , and  $f_o'$  are the empirical parameters particular to the soil type and the effect of cycled wetting and drying. For Eq. 9.2, the intake opportunity time,  $\tau$ , is cumulative; that is, the sum of opportunity time over the number of surges applied.

The flow rate in a dry furrow section being initially wetted by a surge is substantially lower than will occur in that section during succeeding surges. Field observations indicate that infiltration can be described by a function somewhere between Eqs. 9.1 and 9.2 for the second surge cycle. In the present version of the models, these changes are approximated using Eq. 9.1 for the dry sections, Eq. 9.2 for the third and succeeding surges, and a transition equation for the second surge.

Letting  $x_{i-2}$  and  $x_{i-1}$  be the advance distances of the  $i - 2$  and  $i - 1$  surges, the transition function is written

$$T = \left\{ \begin{array}{ll} \left( \frac{x_{i-1} - x}{x_{i-1} - x_{i-2}} \right)^\lambda & x_{i-2} \leq x \leq x_{i-1} \\ 0 & x < x_{i-2} \text{ or } x > x_{i-1} \end{array} \right\} \quad (9.3)$$

in which  $x$  is the location of the computational point of interest during the current time step (i) and  $\lambda$  is an empirical nonlinear distribution constant. Then the infiltration equation coefficients for the transition infiltration function are:

$$k'' = k + (k - k')T \quad (9.4)$$

$$a'' = a + (a - a')T \quad (9.5)$$

and

$$f_o'' = f_o + (f_o - f_o')T \quad (9.6)$$

In order to provide a nonlinear transition, values of  $\lambda$  in Eq. 9.3 can range from 2 to 5.

Infiltration equations, such as Eq. 9.1, are based on cumulative opportunity time. The infiltrated volume added by a particular surge must therefore be computed as a difference. For instance, if at point  $x$ , the opportunity time prior to the ongoing surge is  $\Gamma$  and the opportunity time created by the present surge is  $\tau$ , the infiltrated volume added during the present surge is

$$Z(t) = Z(\Gamma + \tau) - Z(\tau) \quad (9.7)$$

**Model verification.** To evaluate the various models, seven sets of continuous flow and four sets of surged flow tests data, given in Tables 9.1 and 9.2, were evaluated. The continuous flow testing is described in Chapters 14 to 16. A selected set of the surge flow testing will be given here.

Figure 9.10 illustrates the surge-by-surge advance and recession trajectories for a Flowell wheel furrow test. The results were similar for the other Flowell and Kimberly data. The combined kinematic-wave simulations of surge flow shown in Fig. 9.11 with the actual and predicted surge advance front locations plotted. Three replications of the Flowell nonwheel furrow tests and two of the Kimberly nonwheel furrow tests are shown.

The results of the recursive volume balance modeling (Essafi, 1983), the zero-inertia modeling (Oweis, 1983), and the hydrodynamic modeling (Haie, 1984) are an essentially the same.

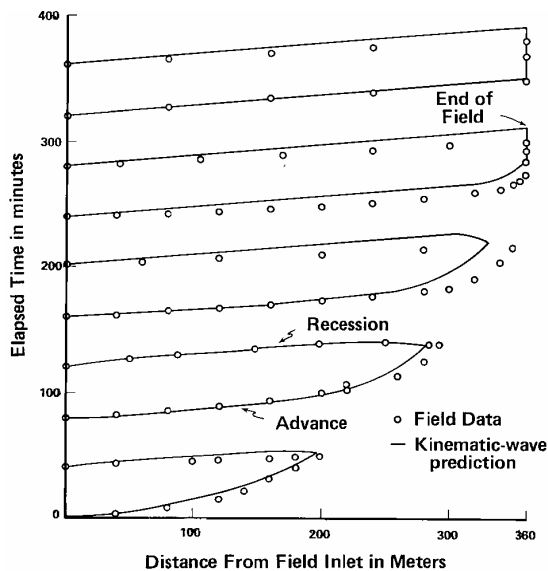
In visually inspecting the field measurements of individual surge advance and recession trajectories, it was concluded that the spatial variability in the soil intake properties has more impact on model performance for surge flow than for continuous flow conditions. The relatively simple approximations contained in Eqs. 9.3 to 9.6 provide a limited capability to deal with this problem but have proved adequate in most cases. However, a substantial research effort is needed to clarify the infiltration processes for surge flow. In the interim, the models should be adequate in most cases to describe the consequences of alternative surge flow practices and to indicate the potential advantage or disadvantage of a surge practice over a continuous flow regime.

The recession phase in surge flow is very important since a significant fraction of the surge-to-surge extension of the field coverage actually occurs during this phase (i.e.,

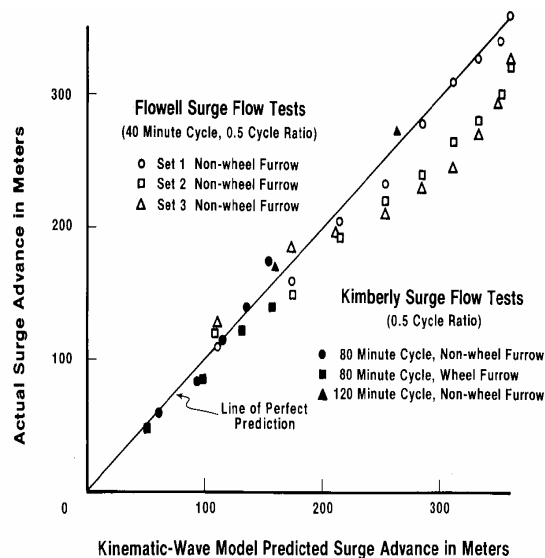
simultaneous advance and recession). The models evaluate this phase of the irrigation very well in the cases studied. However, recession is very difficult to monitor in the course of taking field measurements and in sloping furrow systems the total process is relatively short. Under surge flow conditions, the model appeared to simulate field observations quite well, particularly the extension of the wetted area during the recession phase.

One important conclusion that emerged from these studies is that any of the models should be satisfactory tools for predicting water advance, intake, and runoff for sloped furrow irrigated systems. Their accuracy is demonstrated with data encompassing a relatively wide range of field and soil conditions. The simpler models are easier to program and execute more rapidly, but do not have the generality of the more complex models.

Current versions of the USU models allow evaluation of cutback under surge flow by reducing either the cycle time or the inflow discharge. All of the models compute the tailwater hydrographs and can therefore evaluate the effects of various cutback options as a means to reduce runoff losses.



**Figure 9.10 Measured and kinematic-wave model simulation of surge flow advance and recession data for the Flowell wheel furrow. (From Walker and Humpherys, 1983, with permission of ASCE.)**



**Figure 9.11 Comparison of measured and calculated surge advance fronts for the kinematic-wave evaluation of the Flowell, Utah, and Kimberly, Idaho, tests. (From Walker and Humpherys, 1983, with permission of ASCE.)**

### ***SURGE FLOW MANAGEMENT***

The practice of surge flow offers the furrow irrigator, and quite possibly other surface irrigators as well, a means to significantly improve irrigation efficiency and thereby lower water, energy, fertilizer, and labor costs. On freshly tined fields, particularly for lighter-textured soils, surging will improve the hydraulics of the advance phase, allowing the irrigator to water the entire length

of the field more uniformly and with smaller depths of application. During subsequent irrigations when advance is less difficult, the surge flow regime becomes one of the most effective means of minimizing field tailwater. It should be noted, however, that surge flow management is more complex than traditional surface irrigation practices. In addition to selecting inflow rates and total times of application as in existing management scenarios, surge flow management also requires the selection of cycle time, cycle ratio, and a cutback strategy.

To illustrate some of the basic concepts of surge flow management, in the following discussion we first outline the management philosophies and then consider a specific example.

## **Management Strategies**

Like all other irrigation systems, surge flow systems are subject to optimization; that is, the system performance varies with both field and operational conditions. Application efficiency can often be increased 5 to 10% by careful selection of a single parameter such as cycle time. The controlling variable appears to be the depth of application required to replenish the root zone water supply. Generally, large depths are more efficiently applied with long cycle times and small depths with short cycle times. Thus the management practices achieving optimal surge flow performance are defined in relation to the required application. For the purposes of the USU surge flow program, the "required application" is considered to be the situation where 90% or more of the root zone deficit at the downstream end of the field has been satisfied.

Advance hydraulics become the central issue for the irrigator as watering begins. Given the depth to be applied, the advance-phase hydraulics must be optimized by proper selection of inflow rates and cycle time. These parameters vary as the field length, soil infiltration characteristics, the effect of surging on infiltration characteristics, furrow shape and size, and surface debris vary. A significant fraction of advance under surge flow occurs after an individual surge is terminated. In other words, water is often advancing along the downstream end of the furrow and receding near the upper end. To make this process work effectively, the volume of water added to the furrow in each surge must be large in comparison to the infiltration along the already wetted length of the furrow and the volume of water needed to fill furrow dead storage in the section previously wetted. Thus for light-textured soils, and long and clogged furrows, inflow rates and cycle times should be large. For the opposite case (heavy soils, short, small, clean furrows), smaller flows and cycle times can be used.

When the water reaches the end of the furrows, the irrigator has several decisions to make. If the system must continue applying water for some period in order to refill the root zone, tailwater losses are likely to be substantial unless the flows are cut back. When these depths have been applied, the system needs to be rotated to the next series of sets. Because of the influence of cycled wetting on infiltration, this cutoff time is difficult to ascertain. Nevertheless, there are four post-advance water management alternatives.

First, the cycle time can be reduced to the point where the furrow infiltration absorbs most if not all of the surge. This is primarily an alternative for longer furrows on lighter soils. Second, the cycle time can be reduced to the point where individual surges combine along the furrow, creating a relatively steady flow at the end of the furrows. This is the original surge flow concept. Some systems may allow opening of furrow inlets on the next advance-phase sets,

thereby providing a continuous flow cutback. Third, the last advance surge can be prolonged enough to refill the root zone. This takes advantage of the differences in infiltration rates between dry and previously wetted regions. Finally, the irrigator has the option of simply continuing the advance cycling until the irrigation is completed.

It might be noted that optimizing surge flow management can only be guaranteed either by simulation model analysis or by extensive field experiences. It is doubtful that field experience can be generalized sufficiently to account for field-to-field and year-to-year variations. Modeling, on the other hand, requires definition of infiltration characteristics field to field, irrigation to irrigation, and year to year. Thus the irrigator and the irrigation engineer are confronted by a difficult design/management problem. None of the simulation models has been programmed for determining optimal surge flow configurations.

Given the complexities of surge flow and the time-space variations inherent with surface-irrigated systems, the eventual application of technology will involve self-calibrated control systems (SCCS). The SCCS would involve (1) a computer-assisted control-logic device housing the surge flow software currently encompassed by the simulation models, (2) field advance-recession and soil moisture sensors to monitor how fast the water fronts are moving (both surface and subsurface), and (3) an automated headland facility monitored and actuated by the controller.

The SCCS would initiate irrigation using default values of flow, cycle time, and so on. Information from the first surge would be processed to determine the dry furrow infiltration parameters and from the second and third to determine the effect of surging. The computer would then estimate the performance of current settings as well as optimized settings. Then if sufficient improvements can be made, the controller would change the system configuration to achieve the desired results. At the end of an irrigation, the system would shut down and begin monitoring crop water use so that the next irrigation can be planned.

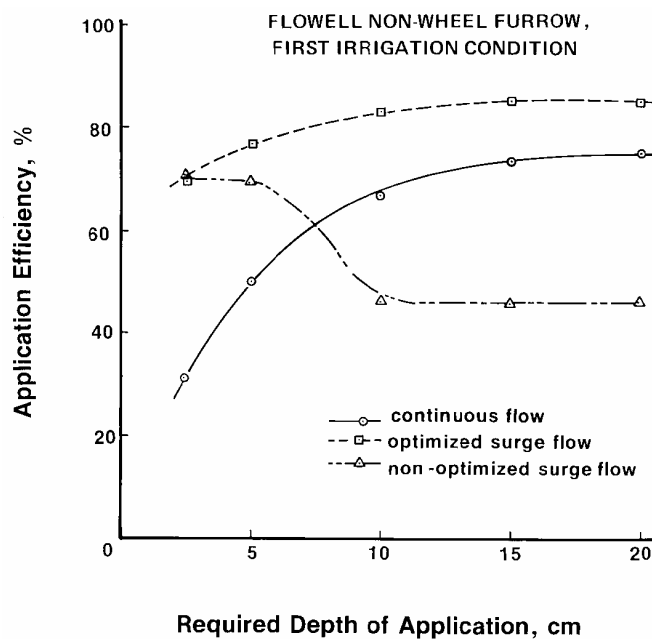
There will be other surge flow management issues raised and resolved before practice is fully implemented. For example, leaching salts from the soil profile using surge flow or adding fertilizers through the system are yet to be studied. Some surface-irrigated field conditions may not benefit from surge flow; some sprinkle and trickle systems may be replaced with a surge system. In any event, the concept of surge flow is a significant step forward in surface irrigation automation.

### **The Flowell Case Study**

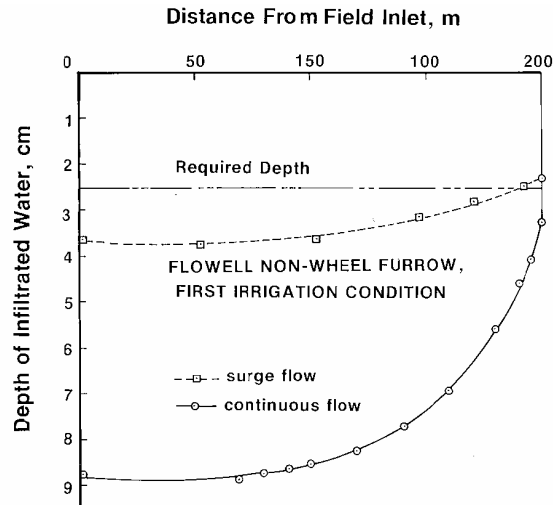
To illustrate the advantage of surge flow, data from the Flowell tests have been reevaluated for the typical first-irrigation, wheel furrow condition. Three furrow irrigation configurations were studied. The first was conventional continuous flow without cutback at the end of the advance phase (the infiltration rates are so high that cutting back tends to dewater the end of the furrows, resulting in poor uniformity). The second is a surge flow regime without any type of cutback, and the third is an optimized surge flow regime (optimal cycle times and cutback regime based on each required depth of application). For this case study, inflow to each furrow was set at the maximum allowable nonerosive discharge.

Figure 9.12 shows the performance of the three scenarios in terms of application efficiency ( $E_a$  as a function of required depth of application. Application efficiency is the ratio of root zone storage to total water applied. Under continuous flow,  $E_a$  increased rapidly from a 2.5-cm (1-in.)

application (32%) to a 10-cm (4in.) application (67%). At higher applications,  $E_a$  increased by another 10%. For non-cutback surge flow (60-min cycles) using the same inflow, the  $E_a$  at lower depths is substantially better than continuous flow. In fact, in a 2.5-cm application, the surge flow system is nearly twice that of the continuous flow. However, as the required application increases, the non-cutback surge system suffers a decline in effectiveness due to high tailwater losses. Because surging reduces intake rates, it is difficult to apply a large depth and thus surge flow systems are expected to irrigate more frequently than traditional practices. If the cutback option is added to the surge flow, substantial overall improvements in application efficiency are made. As will be seen shortly, the gain is due primarily to much higher uniformities. The specific values of cycle time vary by required depth under the optimal strategy. At low depths a 60-min cycle (30 min off) was used. At 10-cm depths, the optimal cycle increased to 180 min.

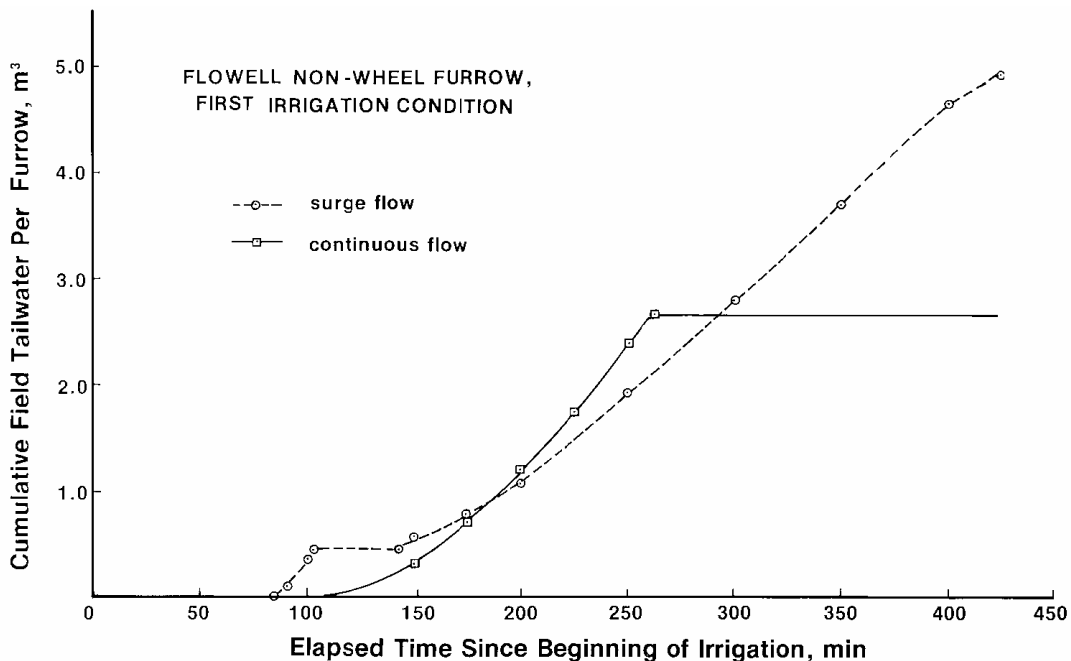


**Figure 9.12 Comparison of attainable application efficiencies under continuous and surge flow management for Flowell nonwheel furrows under first irrigation conditions.**



**Figure 9.13 Distribution of infiltrated water under continuous and surge flow for a 2.5-cm application (Flowell nonwheel, first-irrigation conditions.)**

The subsurface profiles and tailwater hydrographs for a required application of 2.5 cm and 10 cm are plotted in Figures 9.13 to 9.16 for the continuous and optimal surge flow system. As illustrated, the major source of inefficiency for low application depth is deep percolation. For higher applications it is field tailwater. High tailwater losses and low deep percolation losses appear to be a significant feature of surge flow, and as noted previously, tailwater management must be an integral component of surge flow management.



**Figure 9.14 Estimated tailwater hydrographs from the Flowell field under continuous and surge flow for a 2.5-cm application.**

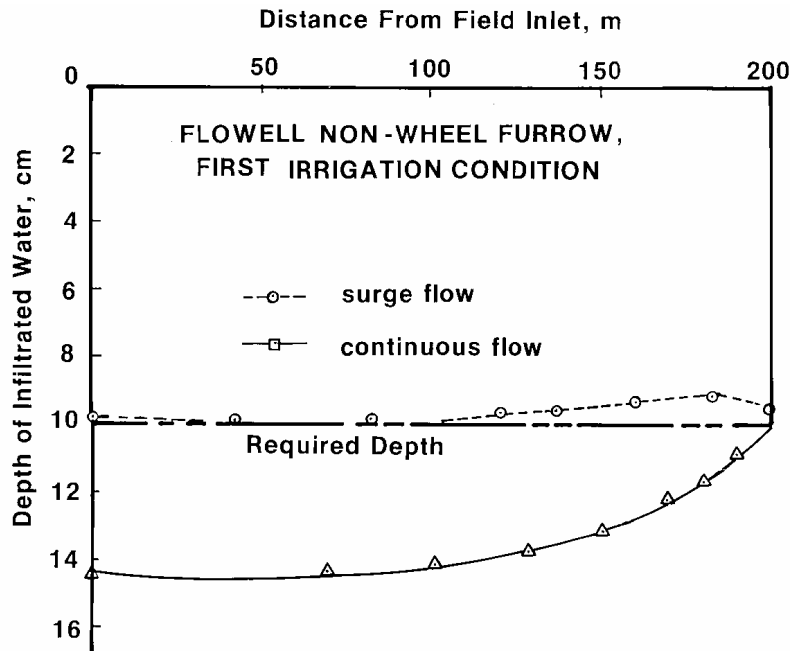


Figure 9.15 Subsurface profiles for a 10-cm application under continuous and surge flow for the Flowell nonwheel, first-irrigation conditions.

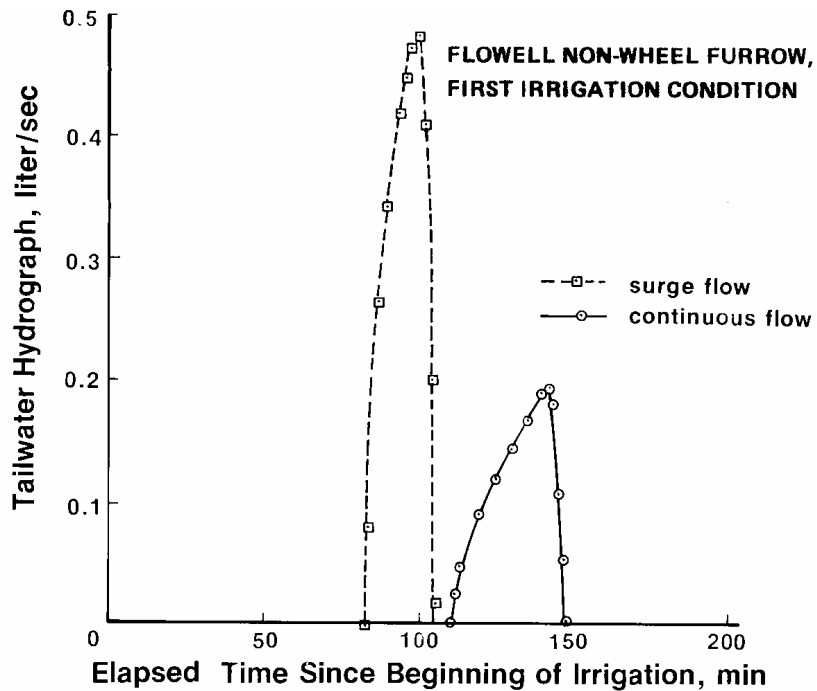


Figure 9.16 Cumulative tailwater losses under continuous and surge flow for a 10-cm application at the Flowell test site.

For other field conditions, such as heavier soils or longer furrow lengths, the tailwater issue is expected to be more pronounced. For these situations, the irrigator may need to reduce the

cutback cycle ratio to one-third or one-fourth. To do this for a one-third cycle ratio it will be necessary to irrigate six sets through the advance phase and then cycle through two sets of three banks during the cutback period.

## ***SUMMARY***

Surge flow offers a number of unique opportunities for water management as well as some problems. These will vary from soil to soil and from farm to farm. Some of the important issues have been discussed and illustrated; others will arise as the concept is applied in other locations. Irrigators, state and federal extension personnel, and irrigation equipment manufacturers in Texas have collectively moved the concept from the research to the commercial level. As others implement surge flow, additional important contributions will be made. Hopefully, researchers will continue to develop a better design and management understanding to serve the many needs of irrigated agriculture. We at Utah State University are gratified by results of our early research and testing. We look forward to a major contribution by surge flow irrigation.

## ***REFERENCES***

- Allen, N. L. 1980. Advance Rates in Furrow Irrigation for Cycled Flow. M.S. thesis, Utah State University, Logan, Utah.
- Bishop, A. A., W. R. Walker, N. L. Allen, and G. J. Poole. 1981. Furrow Advance Rates under Surge Flow Systems. *ASCE J. Irrig. Drain. Div.* 107 (IR3):257-264.
- Blair, A. W., and E. T. Smerdon. 1985. Effect of Surge Cycle Ratio and Cycle Time on Infiltration. *Proc. ASCE Irrig. Drain. Div. Spec. Conf.*, San Antonio, Texas.
- Coolidge, P. S. 1981. Advance Rates under an Automated Pulsed Flow Irrigation System. M.S. thesis, Utah State University, Logan, Utah.
- Coolidge, P. S., W. R. Walker, and A. A. Bishop. 1982. Advance and Runoff in Surge Flow Furrow Irrigation. *ASCE J. Irrig. Drain Div.* 108 (IR1):35-42.
- Elliott, R. L., and W. R. Walker. 1982. Field Evaluation of Furrow Infiltration and Advance Functions. *Trans. ASAE* 25 (2):396-400.
- Essafi, B. 1983. A Recursive Volume Balance Model for Continuous and Surge Flow Irrigation. M.S. thesis, Utah State University, Logan, Utah.
- Evans, R. G., J. A. Aarsted, D. E. Miner, and M. W. Kroeger. 1985. Crop Residue Effects on Furrow Irrigation Advance and Infiltration. Pap. 85-2586. ASAE Winter Meeting, Chicago, Ill.
- Hale, N. 1984. Hydrodynamic Simulation of Continuous and Surged Surface Flow. Ph.D. dissertation, Agricultural and Irrigation Engineering Department, Utah State University, Logan, Utah.
- Izuno, F. T., T. H. Podmore, and H. R. Duke. 1985. Infiltration under Surge Irrigation *Trans. ASAE* 28(2):517-521.
- Malano, H. M. 1982. Comparison of the Infiltration Process under Continuous and Surge Flow. Thesis, Utah State University, Logan, Utah.
- Oweis, T. Y. 1983. Surge Flow Furrow Irrigation Hydraulics with Zero-Inertia. Ph.D. dissertation, Utah State University, Logan, Utah.

- Podmore, T. H., and H. R. Duke. 1982. Field Evaluation of Surge Irrigation. Pap. 82-2012. ASAE Summer Meeting, Madison, Wis., June 27-30.
- Poole, G. J. 1981. Infiltration and Advance under Surge Flow Furrow Irrigation. M.S. thesis, Utah State University, Logan, Utah.
- Stringham, G. E., and J. KelleR. 1979. Surge Flow for Automatic Irrigation. 1979. *ASCE Irrig. Drain. Div. Spec. Conf.*, Albuquerque, N.M., July.
- Walker, W. R., and A. S. Humpherys. 1983. Kinematic-Wave Furrow Irrigation Model. *ASCE J. Irrig. Drain. Div.* 109(IR4): 377-392.
- Walker, W. R., and T. S. Lee. 1981. Kinematic-Wave Approximations of Surged Furrow Advance. Pap 81-2544. ASAE Winter Meeting, Chicago, Ill., December 15-18.
- Walker, W. R., H. Malano, and J. A. Replogle. 1982. Reduction in Infiltration due to Intermittent Wetting. Pap. 82-2029. ASAE Summer Meeting, Madison, Wis., June 27-30.
- Wallender, W. W. 1985. Furrow Model with Spatially Varying Infiltration. Pap. 85-2589. ASAE Winter Meeting, Chicago, Ill.

---

## ***Chapter 10. Land Leveling***<sup>13</sup>

---

### ***INTRODUCTION***

Because the land surface must serve as the major conveyance in all surface irrigation systems, it must be formed so water movements will be as uniform as possible. This is equivalent to the design of laterals and manifolds for a sprinkle or trickle irrigation system when pipe diameters are selected such that pressure and discharge variations over the field fall within prescribed limits.

There are two land-leveling philosophies. The first is to provide a slope which maximizes the effectiveness of an existing or planned irrigation system. The second is to grade the field to its best condition with minimal earth movement. In the latter philosophy, the design of the irrigation system is undertaken to make the system as efficient as possible with the improved field topography. Because land leveling is expensive and large earth movements leave significant areas of the field without fertile topsoil, the general practice has been the second approach. It will also be the approach described in this chapter.

The topographical modification of a field surface is described by several terms. A major earth-moving project is usually called "land leveling" or "grading," whereas the smoothing of small irregularities and roughness is referred to as "land planning," "smoothing," or "floating." Herein, the terminology will be simplified by aggregating each of these operations into a general term, "land leveling," following the U.S. Department of Agriculture (1970).

### ***GENERAL CONSIDERATIONS***

Land leveling generally provides the irrigator with the capability to utilize water, labor, and energy resources more effectively. However, in the near term, the land-leveling operation can prove to be the most intensive and disruptive practice that will be applied to the field. As a result, several factors should be considered before the land-leveling operation begins.

Major topographical changes are almost certain to reduce crop production unless special attention is given to improving fertility in the cut areas with added soil amendments and fertilizers. As a rule, topsoil will be removed from some locations and deposited at others, thereby removing the primary source of nutrients for the crop. In some cases, the topsoil is completely removed, deposited off-field, and then "re-installed" after the field grade has been prepared. This practice is almost always more expensive than the temporary losses due to variations in soil fertility and texture. Nevertheless, one can often see cuts as shallow as 5 cm reduce yields to practically nothing for several years following land leveling unless deliberate efforts are made to restore fertility to these areas.

Similarly, areas where leveling equipment passes repeatedly can be so compacted or pulverized that water penetration is reduced for some time, thereby reducing yields. Thus a land-leveling operation should be preceded by attention to soil characteristics.

---

<sup>13</sup> Taken from Walker and Skogerboe (1987), and Walker (1989).

The climate of the area must be carefully considered prior to land leveling. Regions of short intense rainfall probably should have limited land slopes, while areas with very large annual rainfalls should avoid any land leveling that hinders surface drainage. The existing slope and the method of surface irrigation should be consistent. Relatively steep slopes are usually more amenable to furrow irrigation than either border or basin irrigation. To utilize the border or basin method on slopes, terraces are likely to be required in order to minimize cuts and fills. The cropping pattern will also affect leveling decisions. High valued crops justify greater leveling costs whereas low valued crops may not be profitable with more than minor leveling.

Farmers have many operations that require their skill and labor. The irrigation system should be designed with their practices and preferences in mind. A field leveled to high standards is generally more easily irrigated than one where undulations require special attention in order to water satisfactorily. Some areas have been leveled several times as irrigators change their operations in response to new technologies and the need for modified irrigation frequencies.

Finally, new equipment is continually being introduced which provides the capability for more precise land-leveling operations. One of the most significant advances has been the adoption of laser control in land-leveling equipment. The equipment has made border and basin irrigation particularly attractive since the final field grade can be very precise. It is not unusual to see the marks of a planter show evenly across a 5 to 10-ha field as the water infiltrates into the soil. These marks may be less than 5 cm high.

### ***SMALL-SCALE LAND LEVELLING***

Most small-scale farming operations rely on animal power or small mechanized equipment which an individual own and operate. As irrigators water their fields season after season they are able to observe the locations of high and low spots on the field. Then as fields are prepared between plantings, soil is moved from the high spots to the low ones. Over a period of several years individual fields are smoothed enough to be watered fairly well. The figure at the right illustrates the use of animal power to level land for rice production<sup>14</sup>. Localized ponding on the field is used to direct the operators to the high and low spots. Since this is a normal land preparation practice, it does not represent an extra task for the irrigator.



can

The next figure<sup>15</sup> shown here is a similar operation using a laser-equipped mechanized tractor and blade to prepare a basin for rice production. In this case the field preparation readies the seed bed for planting. Between the powered system and the laser-guided systems may observe various levels of mechanization and array of implements. The one feature common small-scale land leveling is the trial and error of the practices and the long-term incorporation



also  
animal-  
one  
an  
to most  
nature  
of land

<sup>14</sup> Taken from International Rice Research Institute, Rice KnowledgeBank.

<sup>15</sup> Taken from International Rice Research Institute, Rice KnowledgeBank

leveling with seed bed preparation.

### ***LARGE SCALE LAND LEVELING***

On larger fields, land leveling is primarily a mechanized process and may be controlled either manually or by laser systems. The land leveling operation may involve substantial earth movements and large cut-haul equipment as shown right<sup>16</sup>, or simpler equipment used to smooth the land shown below.<sup>17</sup>



One of the most revolutionary technologies

that have been introduced in land leveling is the guidance and control of the equipment by computerized laser systems. The basic principal for the laser control systems involves first the installation of a transmitter that will extend a rotating laser beam across the field to be leveled. The rotating beam forms a radiated plane. The plane can be broadcast as a sloped plane in one or two directions as well as simply a level plane. The slope of the laser plane depends on the design slope of the field in as much as it will serve as the reference for the final field grade.

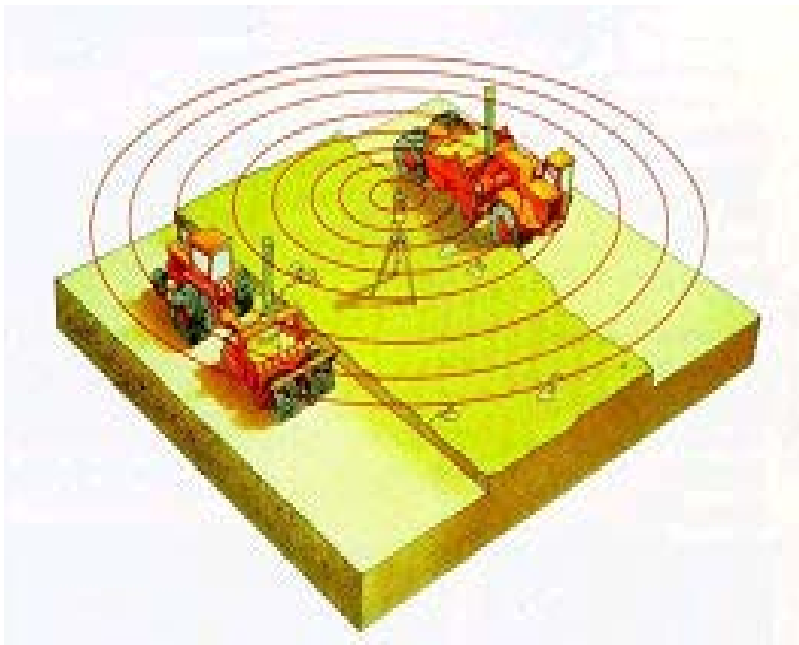
A receiver is mounted on the grading equipment as shown above. The laser plane is detected by elements on the receiver which can indicate variations in the equipment elevation relative to the plane. Computerized controls linked to the tractor's hydraulic system record deviations and activate adjustments in the hydraulically controlled level of the grading blade, and thereby maintain an accurate field surface grade. A pictorial summary of the laser leveling concept is shown below.<sup>18</sup>

---

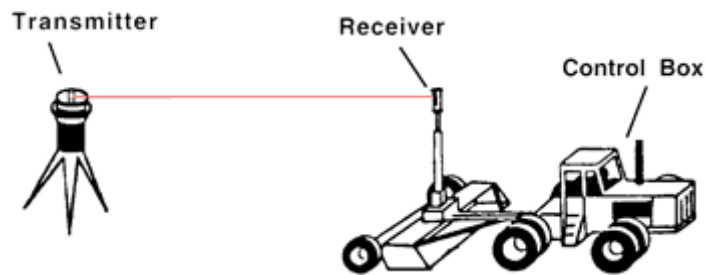
<sup>16</sup> Taken from International Rice Research Institute, Rice KnowledgeBank

<sup>17</sup> Taken from International Rice Research Institute, Rice KnowledgeBank

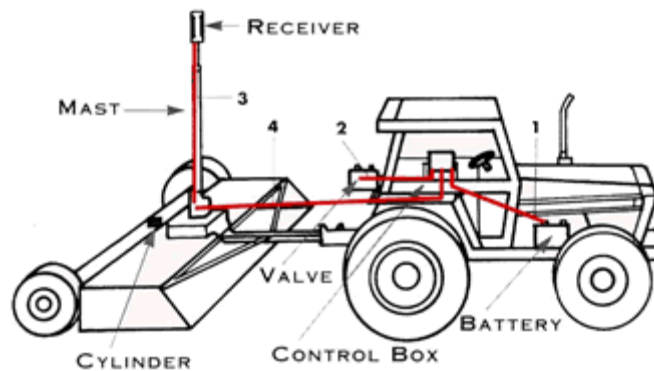
<sup>18</sup> Used by permission of Trimble Navigation Limited, Dayton, Ohio.



Portions © 2001 Trimble Navigation Limited. All Rights Reserved



Portions © 2001 Trimble Navigation Limited. All Rights Reserved



Portions © 2001 Trimble Navigation Limited. All Rights Reserved

### ***TRADITIONAL LAND LEVELING PROCESS***

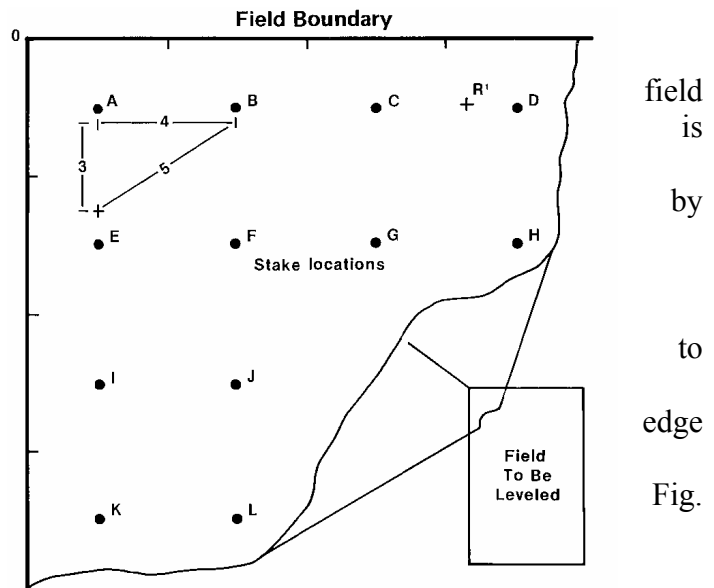
After the engineer and irrigator have studied the field conditions and decided on overall irrigation strategy, the land-leveling program can be initiated. Hart (1975) outlines five general steps as follows:

1. The land must be cleared of vegetation that would impede equipment operation as well as any large debris located on the field. Depending on the equipment being used and the density of the surface, the soil may require cultivation. If the equipment loads earth and carries it to fill areas, it is better not to have loose surface conditions. However, if a smooth operation is involved, a loose soil is preferable.
2. The existing topography needs to be determined. For manual control equipment, leveling will also necessitate staking the field in a uniform grid, whereas laser-controlled systems need only measure and record the field profile.
3. The modified field surface should be determined based on computation of longitudinal and lateral slopes.
4. Cut-and-fill volumes need to be calculated. Based on this information, the grid stakes must be marked with cut-and-fill depths for the operators. Note that laser-controlled operations need only determine the balanced cut-fill volume.
5. The leveling operation is undertaken and followed by a check on the finished grade to ensure that the design has been achieved.

In the sections that follow, steps 2 through 5 will be outlined as if each were required.

### Land Survey and Mapping

The first step in surveying and mapping the field is to set a uniform grid system on the field. One corner of the field is chosen as a reference point and a stake located one-half spacing from either boundary. This is illustrated in Fig. 10.1 the stake A. Then a row of stakes is measured and set using an engineer's level and a tape. The level is set up over stake A and sighted along a line parallel the boundary. Usually, this is accomplished by going to the opposite and locating a stake one-half grid spacing from the edge (see stake R in 10.1). Then, using the level for alignment, the first row of stakes is measured into place (A, B, C, and D).



**Figure 10.1. Field staking process for field surveying and mapping.**

With the instrument located over stake A and aligned along the A, B, C, D row, the next step is to turn the alignment  $90^\circ$  by either measuring a 3-4-5 triangle, as shown, or by using the instrument angle indicators if available. The new alignment is used to locate the stake row, A, E, I, K, as before. The instrument can then be located over stakes E and F to orient rows E, F, G, H and B, F, J, L. Each of the remaining stakes can be placed visually by sighting against the two stakes at the field edges.

The field stakes provide the basis of the field survey. The level or transit can be located in a central area and rod readings taken from each stake position. It is generally advisable to

locate a benchmark near the field from which to reference the readings as elevations. Readings taken from the location of water supply structures are also useful for designing the headland facilities of the surface irrigation system. It is assumed that the basic principles of land surveying are known and practiced during this phase of the land-leveling operation.

### Selecting Field Slopes

An initial decision as to the specific type of surface irrigation system to be utilized will limit field slope. Basins are designed without slopes in either the advance direction or across the field. Borders are similar in having zero cross-slope, but may have advance slopes of 0.05 to 0.1%, depending on crop and soil conditions. Furrow irrigation systems work well with advance slopes of 0.5 to 3% and cross slopes of 0.5 to 1.5%. If the average natural slopes are greater than these ranges, terraces or benches should be constructed.

From a theoretical viewpoint, land slopes can be designed to improve the performance of the surface irrigation system. However, the infiltration rates and roughness change so drastically during the course of an irrigation season that it is generally more practical to shape the field for minimum disturbance or least cost and then adapt an efficient irrigation design and operation for the resulting condition. There are several ways to determine the "new" field shape, including some that are inspection methods requiring experienced judgment. A formal method, called the "plane method," will be used here.

The plane method is a least-squares fit of field elevations to a two-dimensional plane with subsequent adjustments for variable cut-fill ratios. If the field has a basic X- Y orientation, the plane equation is written as:

$$EL(X, Y) = AX + BY + C \quad (10.1)$$

where EL = elevation of the X, Y coordinate, m;  
 A, B = regression coefficients;  
 C = elevation of the origin, m.

Evaluation of the A, B, and C constants can be accomplished using a four-step procedure. The first is to determine the weighted-average elevations of each stake row in both field directions—the advance-slope and cross-slope directions, respectively. The purpose of the weighting is to adjust for the boundary grid points that may represent larger or smaller areas than given by the standard grid dimension due to irregular field shapes and sizes. The weighting factor is defined as the ratio of actual area represented by a grid point to the standard area:

$$\theta_{ij} = \frac{A_{ij}}{A_s} \quad (10.2)$$

where  $\theta_{ij}$  = weighting factor of the grid point identified as the *i*th advance-slope stake row and the *j*th cross-slope stake row  
 $A_{ij}$  = area represented by the (i, j) grid point  
 $A_s$  = area represented by the standard grid dimensions

Using Eq. 10.2, the average elevation of the *i*th row,  $EL_i$ , is

$$EL_i = \frac{\sum_{j=1}^{N'} \theta_{ij} EL_{ij}}{\sum_{j=1}^{N'} \theta_{ij}} \quad (10.3)$$

where  $N'$  is the number of cross-slope rows and  $EL_{ij}$  is the elevation of the  $(i,j)$  coordinate found from field measurements  $EL(X, Y)$ .

A similar expression can be written for finding the average elevation of the  $j$ th cross-slope row,  $EL_j$ :

$$EL_j = \frac{\sum_{i=1}^{N''} \theta_{ij} EL_{ij}}{\sum_{i=1}^{N''} \theta_{ij}} \quad (10.4)$$

where  $N''$  is the number of stake rows in the cross-slope direction.

The second step is to locate the centroid of the field with respect to the grid system. For convenience, an origin can be located one grid spacing in each direction from the first stake position (i.e., stake A in Fig. 10.1). The distance from the origin to the centroid in the X dimension is found by

$$X = \frac{\sum_{j=1}^{N'} \theta_j X_j}{\sum_{j=1}^{N'} \theta_j} \quad (10.5)$$

where  $X$  is the distance from origin to centroid,  $X_j$  is the X distance from origin to the  $j$ th stake row position, and

$$\theta_j = \sum_{i=1}^{N''} \theta_{ij} \quad (10.6)$$

Similarly,

$$Y = \frac{\sum_{i=1}^{N''} \theta_i Y_i}{\sum_{i=1}^{N''} \theta_i} \quad (10.7)$$

where  $Y$  is the Y distance from the origin to centroid,  $Y_i$  is the Y distance from origin to the  $i$ th stake row position, and

$$\theta_i = \sum_{j=1}^{N'} \theta_{ij} \quad (10.8)$$

The third step is to compute a least-squares line through the average row elevations in both field directions. The slope of the best-fit line through the average X-direction elevation ( $EL_j$ ) is A and is found by

$$A = \frac{\sum_{j=1}^{N'} X_j EL_j - \frac{\left(\sum_{j=1}^{N'} X_j\right)\left(\sum_{j=1}^{N'} EL_j\right)}{N'}}{\sum_{j=1}^{N'} X_j^2 - \frac{\left(\sum_{j=1}^{N'} X_j\right)^2}{N'}} \quad (10.9)$$

For the best-fit slope in the Y-direction, the slope, B, is

$$B = \frac{\sum_{i=1}^{N''} Y_i EL_i - \frac{\left(\sum_{i=1}^{N''} Y_i\right)\left(\sum_{i=1}^{N''} EL_i\right)}{N''}}{\sum_{i=1}^{N''} Y_i^2 - \frac{\left(\sum_{i=1}^{N''} Y_i\right)^2}{N''}} \quad (10.10)$$

Finally, the definition of the best-fit plane represented by Eq. 10.1 is completed by determining C. The average field elevation can be found by summing either  $EL_i$  or  $EL_j$  and dividing by the appropriate number of grid rows. This elevation corresponds to the elevation of the field centroid (X, Y). Thus Eq. 10.1 can be solved for C as follows:

$$C = EL_F - AX - BY \quad (10.11)$$

where  $EL_F$  is the average field (or centroid) elevation.

The value of each grid point elevation can be recomputed with Eq. 10.1 and compared to the measured values. The differences are the necessary cuts (computed EL smaller than measured E) or fills. Before these computations are undertaken, however, the slopes in both field directions must be checked to see if they are within satisfactory limits. If they are not, adjustments must be made. For example, if the intended system is a border irrigation system, the cross-slope should be zero ( $A = 0$ ) and the cuts and fills would need to be based on this condition. A second note concerns the fact that cuts and fill do not balance because of variations in soil density. This adjustment is discussed in a subsequent section.

### Example Field Slope Computations

A small rectangular field illustrated in Fig. 10.2 has been staked on a 30- by 30-m grid spacing. The first stake, located at the upper left-hand corner, was placed one-half spacing from both sides of the field to start the staking. An engineer's level and rod were used to measure elevation at each stake, as shown in the figure. The field is to be furrow irrigated and the least

disturbing cut-fill plane is to be determined. The field is most likely to be irrigated from bottom to top as they appear in the figure.

The first step is to calculate the average row elevations. Weighting factors as follows:

i	j			
	1	2	3	4
1	1.0	1.0	1.0	1.33
2	1.0	1.0	1.0	1.33
3	1.0	1.0	1.0	1.33
4	1.0	1.0	1.0	1.33
5	1.17	1.17	1.17	1.56

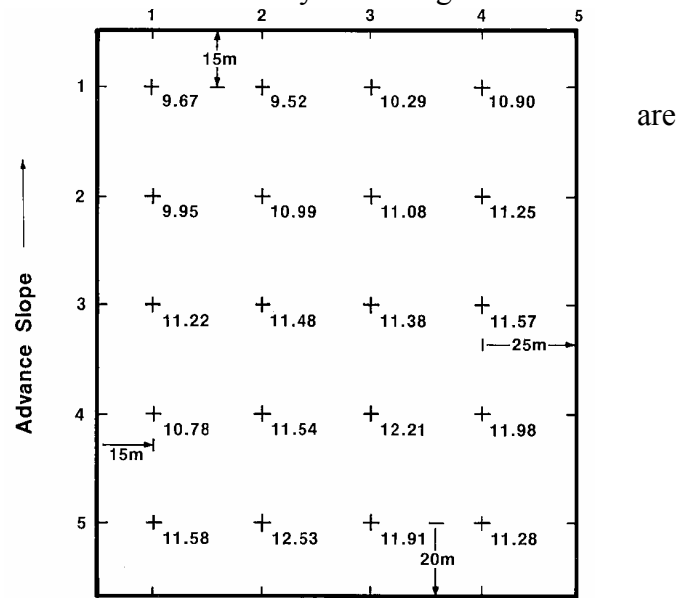


Figure 10.2 Typical grid of surveying stakes on a rectangular field. Normal grid spacing is 30 m by 30 m.

Using Eqs. 10.3 and 10.4, the average advance-slope and cross-slope row elevations are as follows:

i	EL <sub>i</sub>			
1	10.156			
2	10.850			
3	11.425			
4	11.654			
5	11.783			
	1	2	3	4
EL <sub>j</sub>	10.671	11.255	11.392	11.392
Average field elevation = 11.176				

The second step is to calculate the centroid coordinates assuming that the origin is one spacing from the first stake. This requires that the sum of the weighing factors (Eqs. 10.6 and 10.8) be calculated and then Eqs. 10.5 and 10.7 applied. The results of these calculations are  $X = 78.437$  and  $y = 91.983$ .

Next, the slope of the plane in both directions is calculated from Eqs. 10.9 and 10.10, resulting in  $A = 0.0076667$  and  $B = 0.013527$ . With these values, the coordinates of the centroid and the average field evaluation, the value of  $C$  is 9.3304. Temporarily ignoring the need to make adjustments for slope limitations and cut/fill ratios, the measured elevations can be subtracted from the computed elevations to identify cuts (negative numbers) and fills (positive numbers). A summary of these results is illustrated in Fig. 10.3.

This example is a case in which of the grid areas are larger than others and total volume of cuts exceeds the total volume of fills. A simple and rapid calculation of these respective volumes can be made as follows:

**Figure 10.3 Summary of cuts (-) and fills (+) for field in Figure 10.2. All units in meters.**

+ .30	+ .68	+ .14	+ -.24
+ .42	+ -.39	+ -.25	+ -.19
+ -.44	+ -.47	+ -.14	+ -.10
+ -.40	+ -.13	+ -.57	+ -.11
+ .01	+ -.70	+ .14	+ 1.00

some  
the  
  
be  
  
the

$$V_c = \sum_{m=1}^{N_c} A_m C_m$$

and

$$V_f = \sum_{n=1}^{N_f} A_n F_n$$

- where  $V_c$  = volume of cuts,  $m^3$
- $V_f$  = volume of fills,  $m^3$
- $A$  = grid area  $m$  or  $n$ ,  $m^2$
- $C_m$  = depth of cut at grid point  $m$ ,  $m$
- $F_n$  = depth of fill at grid point  $n$ ,  $m$

The cut/fill ratio  $R$  is

$$R = \frac{V_c}{V_f} \tag{10.14}$$

and should be in the range of 1.1 to 1.5, depending on the soil type and its condition. For the example above, the volume of cuts is  $3,664.5 m^3$  and the volume fills is  $3303.50$ , which yield a cut/fill ratio of 1.11. If this value is too low, the plane is lowered by reducing the value of  $C$  and the cuts and fills recomputed. If  $R$  is too high, the adjustment proceeds in the opposite direction. A methodology to adjust  $R$  is given in the next section.

### Adjusting Cut/Fill Ratios

Hart (1975) and Marr (1967) discuss the necessity of having cut/fill ratios greater than 1 for land-leveling operations. Specific reasons are not identified, but machinery compaction in the fill areas and an optical illusion leading to excess fill are cited. However, even laser plane systems, where fill area compaction is minimal and no operator optics are involved, require cut/fill ratios greater than 1. Consequently, one must conclude that the disturbance of the soil reduces its density, contrary to what one might expect.

Selecting a cut/fill ratio remains a matter of judgment. If the value arrived at by least squares requires modification, the procedure is to find the adjustment to original elevation ( $C$ ), which yields the new value of  $R$ . For an increase in  $R$ ,

$$\delta = \frac{RV_f - V_c}{\sum_{i=1}^{N_c} A_i (1 + R)} \tag{10.15}$$

Equations 10.14 and 10.15 assume that none of the cut grid points become fill points, and vice versa.

### Computing Cut Volumes for Contractors

Equation 10.12 is usually less formal for contracting purposes than is required. Some more complete estimators include the prismoidal formula, the "average-end-area method," and the "four-comers method." The four-comers method is simplest to use and is suggested by the USDA (1970). The formula for all complete grid spacings is

$$V_{ci} = \frac{A_i \left( \sum_{j=1}^{N_c} C_j \right)^2}{4 \sum_{j=1}^{N_c} C_j + \sum_{m=1}^{4-N_c} F_m} \quad (7.16)$$

where  $A_i$  is the area of the grid square  $i$  in  $m^2$  and  $N_c$  is the number of cuts at the four corners of the grid square.

At the field edges and corners, if complete grid spacings are not present, the cut volume must be computed separately. The procedure is to assume that the elevations of the field boundaries are the same as those of the nearest stake and would thereby have the same cut or fill dimensions. Equation 7.17 is then utilized with the appropriate  $A_i$  value corresponding to the actual edge area.

### ***OTHER CONSIDERATIONS***

Anderson et al. (1980) present a very good discussion of a number of miscellaneous factors that need to be considered in land leveling. Four of these factors are summarized in this chapter: (1) subdividing a field to minimize earth movements, (2) field operations, (3) miscellaneous earth requirements, and (4) maintenance.

#### **Field Subdivision**

As noted previously, land leveling is likely to be not only the most disruptive operation applied to the field but also the most costly. One method of reducing cut volumes is to subdivide the field in the cross-slope direction and level the field in terraces. Figure 7.4 shows a field with a 0.1% cross-slope and three alternative subdivisions, along with the cut volume per meter of field length. It can be seen that subdividing the field proportionately reduces the cut volume.

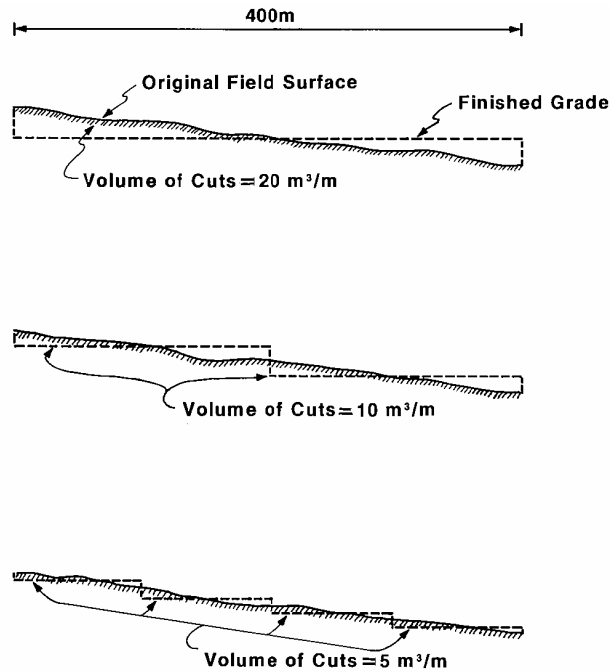


Figure 10.4 Field sub-divisioning to reduce land-leveling requirements.

## Field Operations

It is possible, and computer codes have been developed, to minimize equipment movement for any field situation. However, few operators utilize these procedures but prefer instead to develop field movement patterns based on their own judgment and experience. A cut-haul-fill pattern of travel that maximizes the efficiency of the land-leveling operation tends to be one in which the routes are of nearly equal length. Such a strategy prevents the overuse of travel lanes and minimizes the haul and return distances.

Where manually controlled equipment is used, many operators establish a benchmark grid over the field by cutting and filling strips on both sides of a stake to the desired grade. Then the median areas can be leveled to grade visually with better precision. Nevertheless, the effectiveness of manually controlled operations is dependent on the skill and experience of the operator. Good operators make cut-and-fill passes which are relatively uniform and their equipment is seen to operate at fairly uniform speeds, particularly during loading passes.

Laser-controlled equipment eliminates the need for operator skill in setting grades but not that required for maximizing the operation efficiency. Efficient cut-haul-fill routes are still required, and where cuts are indicated greater than the power of the equipment, the operator must temporarily override the laser control. In central Utah, where laser-controlled equipment is now in widespread use to convert sloping borders to level basins and used to improve the grade of the borders, it has become common practice to employ both manual and laser-controlled equipment on the same job. A reference grid of single-width strips is made by the laser equipment, then the manually controlled equipment is used to make the major cuts and fills ("roughing in" the field), and finally, the laser-controlled machinery comes back and smooths the field to its finished grade. This practice stems from the type of equipment being used. The laser machinery is often designed to operate mainly in planing rather than in cut-and-haul and is therefore not particularly efficient where a large volume of earth must be moved.

## **Miscellaneous Earth Requirements**

Land leveling is often accompanied by improvements or changes in other components of the surface irrigation system. Earth may be used to raise the elevation of roadways or to prepare a raised pad for headland facilities. In the computations setting field cuts and fills, the volume of the earth needed for these miscellaneous requirements should be deducted in the cut-fill ratio calculation.

## **Maintenance**

The topography of surface-irrigated fields, even after leveling, is not a static feature of the land. Year-to-year variations in tillage operations, such as plowing, disking, chiseling, or cultivation, disturb the surface layers as well as shifting their lateral position. The loose soils may settle differently depending on equipment travel or depths of irrigation water applied. Consequently, a major land-leveling operation will correct the macrotopographical problems but annual leveling or planing is needed to maintain the field surface by correcting microtopographical variations.

Because the land-leveling operation disturbs the topsoil on a field, an important aspect of field maintenance is fertility management. In cut areas, additional fertilizers and organic matter should be applied to restore fertility and soil tilth. Cut areas also tend to exhibit the effects of soil salinity, and measures aimed at increasing the leaching fraction in these areas may be worthwhile.

## **REFERENCES**

- ANDERSON, C. L., A. D. HALDERMAN, H. A. PAUL, and E. RAPP. 1980. Land Shaping Requirements. Design and Operation of Farm Irrigation Systems. ASAE Monogr. 3, St. Joseph, Mich., Chap. 8.
- HART, W. E. 1975. Irrigation System Design. Department of Agricultural and Chemical Engineering, Colorado State University, Fort Collins, Colo.
- MARR, J. C. 1967. Grading Land for Surface Irrigation. Circ. 408. California Agricultural Experiment Station, University of California, Davis, Calif.
- U.S. Department of Agriculture, Soil Conservation Service. 1970. Land Leveling, National Engineering Handbook, U.S. Government Printing Office, Washington, D.C., Chap. 12.
- Walker, W.R. 1989. "Guidelines for Designing and Evaluating Surface Irrigation Systems." Irrigation and Drainage Paper, #45, Food and Agriculture Organization of the United Nations, Rome, Italy. 137 pp.
- Walker, Wynn R. and Gaylord V. Skogerboe. 1987. *Surface Irrigation: Theory and Practice*. Prentice-Hall Inc., Englewood Cliffs, NJ. 386pp.