

## Basic overview of composting toilets (with or without urine diversion)

*Draft version*

*Last updated: 14 September 2010*

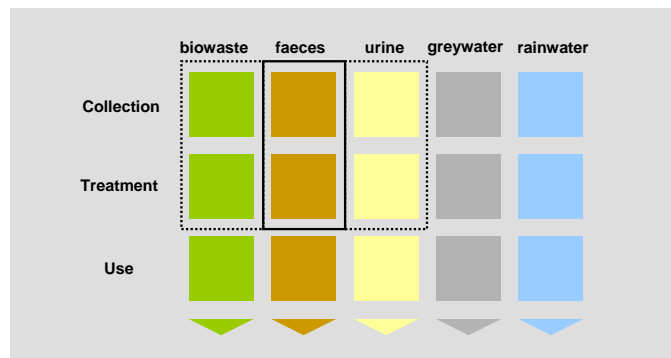

### Preface and acknowledgements

Dear Reader,

This document is a revised version of four separate documents (technical datasheets) on “composting toilets” which were published on the GTZ ecosan website in 2005. Authors of those four documents were Christine Werner, Aileen Huelgas, Florian Klingel and Patrick Bracken (in 2005 they were all working for the GTZ ecosan team). This revision has become necessary to include new findings from research and full-scale installations. The update was written primarily by Wolfgang Berger. We thank Patrick Bracken for his critical comments during the reviewing process.

If you spot omissions or errors, please e-mail us your feedback at [ecosan@gtz.de](mailto:ecosan@gtz.de).

We hope that you find this publication useful for your own sustainable sanitation projects and dissemination activities.

Kind regards,

Dr. Elisabeth von Münch

Leader of GTZ program „Sustainable sanitation – ecosan“  
(program carried out on behalf of the German Federal Ministry for Economic Cooperation and Development (BMZ))

Main author: Wolfgang Berger  
Edited by: Dr. Elisabeth von Münch, Dipl.-Ing. Jürgen Stäudel

*Please send feedback and comments to the e-mail address given below. We look forward to hearing from you.*

Deutsche Gesellschaft für Technische  
Zusammenarbeit (GTZ) GmbH  
ecosan program  
Dag-Hammarskjöld-Weg 1-5  
65760 Eschborn, Germany  
T +49 6196 79-4220  
E [ecosan@gtz.de](mailto:ecosan@gtz.de)  
I <http://www.gtz.de/ecosan>

This document is available from:  
[http://www.gtz.de/en/themen/umwelt-  
infrastruktur/wasser/9397.htm](http://www.gtz.de/en/themen/umwelt-infrastruktur/wasser/9397.htm)

partner of

**sustainable  
sanitation  
alliance**

## Contents

<b>1</b>	<b>Summary and target audience</b>	<b>4</b>
<b>2</b>	<b>Introduction</b>	<b>4</b>
2.1	Scope of this document	4
2.2	General description	4
2.3	Functional principles	5
2.3.1	Biological composting process	5
2.3.2	Bulking material	5
2.3.3	Ventilation	5
2.3.4	Hygiene (pathogen removal)	6
2.3.5	Optimum water content	6
2.3.6	Management and reuse of leachate	7
2.4	Available technologies	7
2.4.1	Toilet and storage facility in one unit or separated	7
2.4.2	Single-vault or multiple-vault toilets	7
2.4.3	Urine diversion versus “mixed composting”	7
2.5	Costs	7
2.5.1	Owner-built or commercially manufactured	7
2.5.2	Low-tech or high-tech systems	8
2.5.3	Cost benefits	8
2.6	Worldwide applicability	8
<b>3</b>	<b>General recommendations for operation</b>	<b>8</b>
3.1	Overview	8
3.2	Cleaning	8
3.3	Maintenance	8
3.4	Composting and secondary treatment	9
3.5	Application and reuse of compost	9
3.6	Hygienic precautions and directives	9
<b>4</b>	<b>Single-vault composting toilets</b>	<b>10</b>
4.1	Functional principles	10
4.1.1	The Arborloo	10
4.2	Operation and maintenance	10
4.3	Extent of application	10
4.4	Hygiene (pathogen removal)	11
4.5	Cost data	11
4.6	Good practice examples	11
<b>5</b>	<b>Multiple-vault composting toilets</b>	<b>12</b>
5.1	Functional principles	12
5.1.1	Rotating multi-chamber	12
5.1.2	Movable squatting plate	12
5.1.3	Fossa alterna	12
5.2	Operation and maintenance	12
5.3	Extent of application	12
5.4	Hygiene (pathogen removal)	12
5.5	Cost data	13
5.6	Good practice examples	13
5.6.1	Example 1 – Sirdo Seco	13
5.6.2	Example 2 – Pacific Island CCD toilet	13
<b>6</b>	<b>Mobile bucket or bin toilets followed by composting of the excreta</b>	<b>13</b>
6.1	Functional principles	13
6.2	Operation and maintenance	14
6.3	Extent of application	14
6.4	Hygiene (pathogen removal)	15
6.5	Cost data	15
6.6	Good practice examples	15
6.6.1	Example 1 – Kiribati, Central Pacific	15
6.6.2	Example 2 – Erdos Eco-Town, Dong Sheng, China	15
6.6.3	Example 3 – Gebers housing project, Stockholm, Sweden	16
<b>7</b>	<b>Composting toilets with mechanical devices</b>	<b>16</b>
7.1	Functional principles	16
7.2	Operation and maintenance	17
7.3	Extent of application	17
7.3.1	Large Systems	17
7.3.2	Small Systems	17
7.4	Hygiene (pathogen removal)	18

7.5	Cost data .....	18
7.6	Good practice example .....	18
<b>8</b>	<b>References .....</b>	<b>18</b>
8.1	References used in this publication .....	18
8.2	References for further reading .....	19
<b>9</b>	<b>Appendix: Range of manufacturers and commercially available composting toilets .....</b>	<b>19</b>

**List of Tables:**

Table 1.	Suggested alternative recommendations for primary treatment of dry faeces before use at household level (source: WHO (2006)) .....	6
----------	--	---

**List of Figures:**

Figure 1.	Cross section of a single-vault composting toilet, showing the ventilation system (source: Berger and Lorenz-Ladener, 2008).....	6
Figure 2.	Brick chamber for faeces composting equipped with vent pipes on the back side and sheltered (photo: W. Berger, 2009 at German Research project at Valley View University, Ghana) .....	9
Figure 3.	Applying faeces compost to the garden soil by mixing with a pitchfork (source: Berger and Lorenz-Ladener, 2008).....	9
Figure 4.	Mature compost from a single-vault composting toilet ready for soil improvement (source: Berger and Lorenz-Ladener, 2008).....	10
Figure 5.	Flow chart of continuous composting toilet (source: Davison and Schwizer 2001) .....	10
Figure 6.	View of a single-vault composting toilet (source: Reed and Shaw, 1999).....	11
Figure 7.	Left: Dry toilet with removable insert and sealed toilet seat. Right: Insulated single-vault composting container with upper lid for maintenance and lower lid for discharge and working platform (both Hamburg-Allermöhe, Germany, source: Berger and Lorenz-Ladener, 2008).....	11
Figure 8.	Owner-built toilet seat with storage for wood chips to cover the pile on a daily basis (Puerto Morelos, Mexico) (source: the ReSource Institute, <a href="http://www.riles.org/projmex.htm">http://www.riles.org/projmex.htm</a> ).....	11
Figure 9.	Owner-built single-vault composting toilet with built-in toilet connection and outside access for maintenance and discharge (Puerto Morelos, Mexico) (source: The ReSource Institute, <a href="http://www.riles.org/projmex.htm">http://www.riles.org/projmex.htm</a> ) .....	11
Figure 10.	Rotating multi-chamber bin (source: Ekolet, Finland).....	12
Figure 11.	Sirdo Seco double-vault toilet in Mexico (source: Winblad and Simpson-Hebert (2004).....	13
Figure 12.	Cross section of the CCD composting toilet with attached greenhouse and evapo-transpiration bed (source: Winblad and Simpson-Hebert (2004).....	13
Figure 13.	Urine diverting dry toilet with bucket under floor (source: Wostman Ecology AB, Sweden) .....	14
Figure 14.	Movable bucket toilet for the addition of sawdust or bark chips. Exchangeable buckets and biodegradable bags can be used (source: Berger Biotechnik, Germany).....	14
Figure 15.	Schematic diagram of movable bin composting toilet (source: Winblad and Simpson-Hebert (2004).....	15
Figure 16.	Movable ventilated collecting bins with overflow for leachate discharge (source : PikkuVihreä, Finland).....	15
Figure 17.	Part view of the multi-story houses in Dong Sheng, showing vent pipes on the roof from the ventilation system (photo : W. Berger, 2009).....	16
Figure 18.	Left : Ceramic urine diverting dry toilet equipped with faeces turning bowl and odour trap for urine. Right : Downpipes coming from each floor leading into separate bins with housing (Erdos Eco-Town, Dong Sheng, China, photos: W. Berger, 2009).....	16
Figure 19.	Sketch of the movable bin system at Gebers apartment block in Stockholm, Sweden (source: Winblad and Simpson-Hebert (2004).....	16
Figure 20.	Cross section of turning drum facility with enforced ventilation (source: Sun-Mar, USA) .....	17
Figure 21.	Cross section of a toilet facility with horizontal stirring unit (source: Seiwa Denko, Japan).....	17
Figure 22.	Cross section of a compact toilet with vertical stirring unit (source: Biolet USA/Switzerland) .....	18

**List of Abbreviations:**

CCD	Center for Clean Development
C/N	Carbon to nitrogen ratio
UDDT	Urine diversion dehydration toilet
UDDTs	Urine diversion dehydration toilets
VIP	Ventilated improved pit latrine
WHO	World Health Organisation

## 1 Summary and target audience

The target audience for this publication are people who:

- want to get an overview of composting toilets, their design, operation and maintenance, and quality of the compost produced;
- want to know of important documents in this field for further reading;
- have an interest in sustainable sanitation solutions in the context of developing countries.

Composting toilets are dry toilets which operate without the need for flushing water. They can be used independently of connections to sewers and provide a safe and hygienic sanitation alternative for a range of possible applications. Composting toilets can considerably reduce household water consumption and the costs for wastewater treatment. They are recognised by the Joint Monitoring Programme of the Millennium Development Goals as one of the possible systems of improved sanitation (UNICEF/WHO, 2008).

This publication explains the design and use of composting toilets which are either manufactured or owner-built. It also briefly describes external composting in a unit which is separate from the toilets (usually located in the garden).

Composting toilets have sometimes also been termed “eco-toilets”. They should not be confused with urine diversion dehydration toilets (UDDTs)<sup>1</sup>. In the latter type of toilet, only drying takes place but no biological composting activities occur.

A composting toilets consists of two basic elements: a place to sit or squat and a collecting or composting device. Additionally a ventilation system allows for good aeration of the composting vault, removal of excess moisture and reduces odour. The emptying frequency of the composting vault depends on the capacity of the container, the feeding rate and the composting conditions.

Composting toilets can be designed with or without diversion of urine; urine diversion simplifies the management of the leachate and can be implemented if there is a demand for urine as a fertiliser.

This publication explains the functional principles of composting toilets such as the biological process, bulking material, ventilation, pathogen removal (hygienisation), optimum water content, management and reuse of leachate and compost.

The publication also gives an overview of the operational requirements for composting toilets. Regular maintenance of composting toilets in private or public use is critical to ensure that the facility is operating well. This involves proper cleaning, controlling of technical components of the facilities and the composting process as well as safe treatment, handling and application of faecal compost and leachate (and urine if it is collected separately).

The main four types of composting toilets are explained in detail:

- Single-vault composting toilets
- Multiple-vault composting toilets

---

<sup>1</sup> UDDTs are sometimes also simplistically called “ecosan toilets” (we do not recommend the use of this term as it generates confusion).

- Mobile bucket or bin toilets followed by composting of the excreta
- Composting toilets with mechanical devices

Ample examples for composting toilets from around the world are included in the publication to show that these types of toilets have a wide range of applications under a variety of circumstances (for wealthy or poor people; for cold, hot, wet or dry climates; for urban or rural settings).

With this publication we aim to make composting toilets more widely known worldwide and to make their potential for providing sustainable sanitation clearer for all those who make decisions on future sanitation systems.

## 2 Introduction

### 2.1 Scope of this document

This document focuses on the design and use of composting toilets which are either manufactured or owner-built. It also briefly describes external composting in a unit which is separate from the toilets (usually located in the garden).

The document does *not* include information on toilets which are designed to use heat and time for drying of the faecal matter in a vault (urine diversion dehydration toilets, UDDTs). Those toilets are described in detailed in a separate technology review (see v. Münch and Winker, 2009).

### 2.2 General description

Composting toilets are dry toilets which operate without the need for flushing water. They can be used independently of connections to water supplies and sewers and provide a safe and hygienic sanitation alternative in areas without conventional sanitation infrastructure. Composting toilets can considerably reduce household water consumption and the costs for wastewater treatment.

In composting toilets faeces and urine are separated from the regular wastewater. Plant nutrients and organic matter are then recycled through composting and the remaining household wastewater can be treated more easily. In this respect, composting toilets act as local pre-treatment systems. They retain substances, which may be harmful to the environment.

The composting process includes the degradation of organic matter by thermophilic<sup>2</sup> aerobic bacteria. Under optimal conditions the bacteria can produce temperatures within the composting heap above 50°C and can therefore provide a fast and substantial pathogen reduction. Due to its complexity, however, the composting process may be difficult to manage within the composting vault. Temperature measurements have shown that it is not easy to reach temperatures above 40° C in the composting vault and the normal operating temperature range is often mesophilic.

---

<sup>2</sup> A thermophile is an organism that thrives at relatively high temperatures, between 45 and 80 °. A mesophile is an organism that grows best in moderate temperature, neither too hot nor too cold, typically between 15 and 40 °C

Pathogen content is nevertheless reduced in a composting toilet, but complete pathogen reduction cannot be guaranteed. Pathogen reduction will most often require either long maturation times or a secondary composting or storage period outside of the toilet vault (WHO 2006).

A strong commitment from the users or operators of composting toilets is necessary to maintain the system properly, which includes handling faecal compost. Most of the toilet systems are easy to use and maintain, so composting toilets can be applied in most parts of the world either as owner-built or low-cost solutions or manufactured and high-tech products.

Composting toilets are a listed technology in the 2006 World Health Organisation Guidelines for the Safe Use of Excreta and Greywater (WHO, 2006) and are recognised by the Joint Monitoring Programme of the Millennium Development Goals as one of five possible systems of improved sanitation (UNICEF/WHO, 2008). These are: flush or pour-flush toilet, latrine connected to a piped sewer system, septic tank, pit latrine, ventilated improved pit (VIP) latrines and composting toilets.

## 2.3 Functional principles

### 2.3.1 Biological composting process

A composting (or biological) toilet system receives and processes excrement and toilet paper in a specially designed container or vault. Some composting toilets combine the treatment of faeces and urine in one vault, while other toilets are specifically designed for the separate treatment of faeces and urine. Biodegradable household waste, including organic food waste, can also be added to the vault. The organic waste will then be biologically degraded in the composting process together with the faeces.

During the composting process the organic matter is biologically degraded by thermophilic aerobic bacteria, fungi and actinomycetes. Under optimal conditions the temperatures within the composting heap rise to between 50 - 70°C due to the biological activity of the bacteria. Therefore a fast and substantial pathogen reduction can be provided by the composting process.

Optimal conditions for the initial thermophilic composting are:

- Good aeration – sufficient oxygen supply
- Water content 45-65%
- C/N ratio 30-40 / 1

Note: These optimal conditions are rarely achieved in composting toilets.

Human excreta and food waste alone do not provide these optimum conditions as both the water and nitrogen content are too high. For that reason bulking material is added to lower the water content, improve the aeration and increase the carbon content of the material.

The toilet itself consists of two basic elements: a place to sit or squat and a collecting or composting device. Additionally a ventilation system allows for good aeration of the composting vault and reduces odour. The emptying frequency of the composting vault depends on the capacity of the container, the feeding rate and the composting conditions.

During the decomposition (or degradation) process, there is a considerable volume and mass reduction through the processes of evaporation, digestion and mineralisation (a reduction of up to 90% of the original volume of the organic waste) that allows for a continuous storage of material in the vault. The final products are CO<sub>2</sub>, heat, water and compost.

Due to the volume and mass reduction in the composting process the relative content of salts and other nutrients (and also heavy metals) increases in the compost. Not all nutrients in the compost are plant available in the first year of application. Compost should not be considered as a fertiliser, but is a very important soil conditioner with fertilising attributes. A further benefit is that it improves the water-holding capacity of soils, which is important for drought prone areas.

### 2.3.2 Bulking material

Human excreta and food waste do not provide optimum conditions for composting. Usually the water and nitrogen content is too high, particularly when urine is not separated and is mixed with the other material in the vault.

Additives or “bulking material”, such as wood chips, bark chips, sawdust, ash and pieces of paper, are recommended to absorb moisture. It also improves the aeration of the pile and balances the carbon demand by adding carbon-rich material. Bulking material also serves as cover of the fresh faeces and reduces the risk of disease transmission by flies and other insects. If bulking material is not added, the organic matter in the vault may compact and form impermeable layers, which leads to wet and anaerobic conditions.

Some bulking material can have an additional positive effect on odour (such as tannin in bark chips) as they bind the substances that cause bad smells.

Many of the micro and macro organisms involved in the biological degradation, cannot survive in acid conditions. Lime and algae flour are essential additives to raise the pH-value if it drops below 6.5.

Bulking material must be added regularly to all composting toilets. Preferably a small amount is added after every use or at least once a day, depending on the frequency of use, to cover the faeces and to prevent bad smell.

### 2.3.3 Ventilation

The toilet vault is normally vented to improve both aeration and the evaporation of excess moisture in the composting heap. The ventilation also provides odour control through negative pressure. Ideally there should be an electrical fan with speed control installed within the vault. The fan will help to balance the comfortable use of the toilet (if air flow is too strong) with odour control (if airflow is too low) and will ensure that cooling and drying of the compost mass is avoided. Instead of an electrical fan, wind-driven fans, pipe insulation and passive solar heated surfaces can improve the ventilation, but the measures are less controllable.

If flies are a problem, a fly screen must be installed over the ventilation pipe and the functioning of the ventilation has to be controlled. Flies are attracted by anaerobic composting conditions and lack of air flow.

Horizontal ventilation channels or pipes at the bottom of the composting vault combined with vertical ventilation

channels or pipes are necessary to ensure sufficient oxygen supply in all areas of the compost pile (see Figure 1).

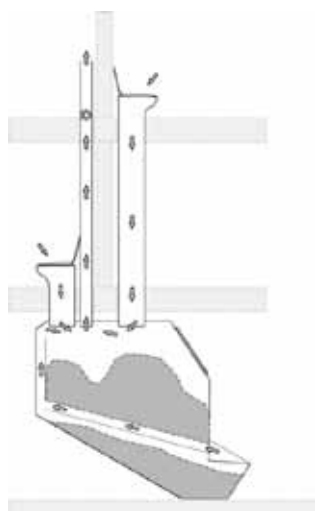

Figure 1. Cross section of a single-vault composting toilet, showing the ventilation system (source: Berger and Lorenz-Ladener, 2008).

### 2.3.4 Hygiene (pathogen removal)

In general compost from toilets is hygienically harmless if thermophilic composting occurs at temperatures of 55°C for at least two weeks or at 60°C for one week. For safety reasons however the World Health Organisation recommends a composting at 55°C – 60°C for one month with a further maturation period of 2 – 4 months in order to ensure a satisfactory pathogen reduction.

The actual process of “composting” as it is used in large scale, biological waste treatment plants, usually refers to an optimised process including an optimum supply of oxygen and water, adjustment to an optimum C/N-Ratio by adding different organic material, hygienisation of the material through optimised process control, temperature control, regular turning of the compost material, etc. until the completion of the composting process.

However due to the relative complexity of ensuring optimal composting conditions in the vault thermophilic temperatures are not achieved in most composting toilets. Considerable pathogen reduction can be achieved in a composting toilet, but *complete pathogen destruction cannot be guaranteed*.

This, however, can be improved by a secondary co-composting with organic solid waste outside of the toilet vault. The compost heap has to be turned periodically (1 - 2 times for one year in northern climates). Other treatment methods include long term storage, high pH value, exposure to UV light and toxicological effects of metabolites<sup>3</sup>.

Hygienic measures for handling of the compost must be applied by all those people who are exposed to it.

Faeces compost that was not exposed to high temperatures or otherwise sanitised should only be applied to ornamental plants, fruit-growing bushes and trees. It should not be applied to food crops such as leafy

<sup>3</sup> Metabolites are the intermediates and products of metabolism. Metabolism is the set of chemical reactions that happen in living organisms to maintain life.

vegetables and root plants. These plants should not be easily accessible in order to minimise the potential risk of infections.

Systems that collect urine in the vault produce a larger volume of leachate. This leachate has to be handled carefully in order to avoid the spreading of pathogens. The handling, discharge and treatment of excess leachate has to be considered in the planning phase of a composting toilet (see Section 2.3.6).

For the treatment of urine from urine diverting toilets please refer to the technology review by v. Münch and Winker (2009).

Table 1. Suggested alternative recommendations for primary treatment of dry faeces before use at household level (source: WHO (2006)).

Treatment	Criteria	Comment
Storage (only treatment) at ambient temperature 2-20°C	1.5-2 years	Will eliminate most bacterial pathogens, substantially reduce viruses, protozoa and parasites, some soil ova <sup>4</sup> – may persist
Storage and alkaline treatment	pH >9 during > 6 months	Temperature <35°, moisture content >25° or lower pH will prolong the time for absolute elimination

### 2.3.5 Optimum water content

The composting microorganisms need a sufficient supply of **nutrients**, which can only be ensured in a watery dilution. Therefore **water** has to be available in sufficient quantities. At the same time the microorganisms need to have sufficient **oxygen** to survive.

In order to balance the demands of the microorganisms, the maximum water content of the compost material is limited. The maximum water content is significantly dependent on the structure of the bulking material.

Organic matter with high absorptive capacity (such as bark, paper) as well as high stability and large pore volume (such as straw) allows for significantly higher water content, than organic matter without sufficient absorptive capacity and stability.

The optimum water content for the composting process of organic matter is within a range of 45-65%, depending on the bulking material. If the water content drops under 25%, the microbial activity decreases significantly and stops completely under 10% of water content.

Therefore the adjustment of an optimum water content is critical and very important for a proper composting process.

As described above, dry material with high absorptive capacity can be added, if the water content is too high. Should the water content be too low, the addition of water is necessary. The required additional water quantity can only be determined through the measurement of the water content.

<sup>4</sup> Eggs or egg cells, here referring to helminths or parasitic worms.

Besides technical measurements there are easy ways for a rough estimation of the water content: for leaves, the "squeeze" test is an easy way to gauge the moisture content: The compost should feel damp to the touch, with only a drop or two of water expelled when tightly squeezed in the hand.

In practise the water content in the vault of composting toilets is difficult to adjust and a certain amount of experience is needed for a good operation of the composting process.

### 2.3.6 Management and reuse of leachate

Composting toilets are designed with a drainage layer, a sieve-tray or a slope in order to ensure that surplus leachate can be drained, stored and removed to a storage tank for further treatment. Anaerobic conditions in the compost can be avoided by these installations.

Some composting toilets are designed to allow for the evaporation of leachate by electrical or solar heating devices. However, this design requires an energy source and results in a loss of nutrients.

Leachate has to be handled with care as it contains pathogens. Its handling, treatment and management must be considered thoroughly in the planning stage. The leachate can be diluted with water and applied to non-food plants as a highly concentrated liquid fertiliser (additional protection such as subsurface application may be needed).

The recommended dilution ratio of leachate with water depends on the plant and its nitrogen requirement. If the leachate is applied to the soil, then no dilution is required. If the leachate is applied directly onto sensitive plants, then it should be diluted. A dilution ratio of 3:1 (water: leachate) is often used, but 10:1 is more conservative. The leachate quality has some similarities with liquid manure (which farmers usually apply undiluted to the soil).

See also Richert et al. (2010) for further explanations on reuse practices for urine, which is similar to leachate in terms of the nitrogen content – but contains much fewer or no pathogens.

## 2.4 Available technologies

### 2.4.1 Toilet and storage facility in one unit or separated

In these systems, small and compact units are equipped with a toilet seat and a mobile bucket or bin for intermediate storage on-site. Using a small storage space, the toilet can be installed at ground level. The collected material must be transported to an external site for subsequent co-composting or any other treatment (digestion, fermentation etc.).

The storage containers need to be emptied more often when compared to larger units with separate storage and treatment space in the basement. Transport and handling in small units may be made easier, if exchangeable buckets or bins are used.

Larger composting toilet systems are mostly applied for year-round use in private houses or public toilet facilities. The toilet and the composting container are separated (the toilet can be located at the ground floor and connected to a container in the basement of the building by a vertical

pipe). The material is usually stored for co-composting on-site in the same unit.

### 2.4.2 Single-vault or multiple-vault toilets

To provide the best conditions for self-heating of the heap and biological diversity, the storage volume of a vault should not be less than 1 m<sup>3</sup>. Single-vault composting through continuous processing is feasible, if there is a separation between fresh and mature solid material. However, fresh liquids may contaminate the finished compost and compost from single-vault systems should undergo a second treatment before its application.

Multiple-vault composting by discontinuous (batch) processing avoids contamination. The vault in use has to be strictly separated from the one not in use. The storage volume is generally smaller (for example 4 x 250 l) than in single-vault systems in order to save space, so self-heating and biological diversity may be limited. If the storage units are too small, the maintenance and process control will be difficult. Double-vault systems are a good compromise: sufficient storage volume is ensured in both chambers while at the same time the re-contamination of the maturing vault with fresh faeces is avoided.

### 2.4.3 Urine diversion versus "mixed composting"

The toilet bowl can be designed either with or without urine diversion devices.

For composting toilets *with* urine diversion the compost may need to be watered, if the water content drops significantly under 40% (the water content of faeces is about 65-80%, which is sufficient for good processing with the addition of toilet paper and bulking agents).

One advantage of collecting urine separately and not within the vault is that the leachate production is reduced. Therefore less effort is needed to balance the nutrient load (optimal C/N-ratio) for the composting process for example by using carbon-rich additives.

Urine diversion is particularly recommended for areas where there is a demand for treated urine as fertiliser and where the use of urine can reduce the overall operational costs of the composting toilet.

In most composting toilets *without* urine diversion, leachate will accumulate at the bottom of the vault and must be drained off. Due to the urine in the composting vault, there is a higher water and nitrogen content which needs to be balanced by adding bulking material for optimal composting conditions.

## 2.5 Costs

### 2.5.1 Owner-built or commercially manufactured

There are many different types and models offered by manufacturers and dealers in many countries within a large range of prices, depending on complexity of the design, the number of units needed, transport costs, production and economic conditions.

Functioning composting toilets can also be owner-built, if they are technically well constructed and assure the operational basics. Construction costs of owner-built toilets are usually lower than manufactured toilet systems, particularly if local material is used and labour costs are low. Owner-built toilets can be a good solution for low

income areas and in locations without any other sanitation infrastructure.

### 2.5.2 Low-tech or high-tech systems

Low-tech composting systems are basically storage facilities, in which excreta are collected and allowed to decompose at ambient temperatures. They may require more maintenance than semi-automatic systems and a higher degree of user involvement in the treatment process. On the other hand they are usually much less expensive than high-tech units.

High-tech units are more compact, if they are equipped with automatic mixers and thermostatically controlled heaters. They require less user intervention, as long as the technical equipment works reliably. However in case of breakdowns, special spare parts and servicing may be required. High-tech composting toilet systems provide a good solution, if space is expensive or limited and technical support is easily available.

### 2.5.3 Cost benefits

Benefits may arise from the final composted product and urine or leachate application in agriculture. Compost is a high quality soil conditioner with attributes of a fertiliser. Urine and leachate water are highly concentrated organic fertilisers. Investment and operational costs of the system (such as power supply, service, lifetime of the system) have to be balanced, depending on the local situation.

## 2.6 Worldwide applicability

Composting toilet systems can be constructed simply and relatively low-tech or mechanised at an advanced technical level. Dry sanitation is particularly suited for arid regions and / or regions without central water supply or sewerage. The equipment and operation of composting toilet systems can be adapted to the technical conditions and cultural needs of industrialised and developing countries respectively.

In some projects composting toilets have been successfully implemented in houses with up to four floors. In terms of operation and maintenance composting toilets are most suitable, if users are committed to operate the system carefully and to accept responsibility for its operation.

Composting toilets require greater management efforts than dehydration toilets. The higher moisture content, which is required for optimal composting conditions (around 50% compared to less than 25% in a dehydration toilet), means that composting toilets need more care and intervention to function correctly (such as adding bulking materials to increase the carbon content and to absorb surplus moisture).

Dehydration toilets tend to be more common in hot developing countries, as they require less investment and maintenance. However the nutrients in compost have a higher plant availability than the product from a dehydration toilet.

Compared to VIP / pit latrines, composting toilets can be built as a permanent structure above ground and even integrated into the house. There is no need to dig a deep pit or to regularly replace the facility when pits are full. The final product can be removed, handled and transported relatively easy.

Compared to water-flushed sanitation systems, composting toilets are usually less expensive than conventional septic systems or sewer systems<sup>5</sup>. They will reduce the total household water consumption by at least 25%.

## 3 General recommendations for operation

### 3.1 Overview

The main purpose of long-term and successful operation of a composting toilet should be

1. the provision of safe and acceptable sanitation facilities for users,
2. the establishment of an attractive environment and
3. the production of safe end products for reuse.

Regular maintenance of composting toilets in private or public use is critical to ensure that the facility is operating well. This involves proper cleaning, controlling of technical components of the facilities and the composting process as well as safe treatment, handling and application of faecal compost, leachate and urine.

### 3.2 Cleaning

- For the cleaning of the toilet bowl, a spray bottle with vinegar or citric acid diluted with water can be used, as both are biological disinfectants. Additionally (if urine is separated) the clogging of urine pipes due to incrustations will be avoided. After spraying, faecal residues inside the bowl can be easily removed by using toilet paper and dropping it into the compost bin afterwards.
- If necessary (for example in public toilets), chemical disinfectants shall be used for surfaces that are touched by hands (toilet seat, door handle, lock and tap).
- If users continuously leave the toilet facility dirty, the reasons should be analysed and the conditions improved (for example sufficient illumination, technical modification or further information about proper use).
- It has to be ensured that tissue paper or water for anal cleaning is available as well as water, soap and clean towels for hand cleaning.

### 3.3 Maintenance

- Proper operation of the facility in accordance with the operation manual of the manufacturer or constructor has to be followed. If problems occur (such as smell, flies, clogging of fluid pipes), the trouble-shooting list of the manufacturer should be consulted or the manufacturer can be consulted directly.
- Structural material (such as wood chips, straw clippings, dry leaves) must be added, if the material becomes too compact and humid. A good supply of oxygen should be ensured by turning the material with a suitable tool (such as pitchfork).

---

<sup>5</sup> Note: costs for sewer lines and wastewater treatment plants have to be considered in a comparative cost calculation.



- In case the material becomes too dry (due to heat or urine separation), water should be added as described.
- Air inlet and outlet pipes should be controlled to ensure the correct functioning of the ventilation, should smell occur.
- The storage or composting bin has to be emptied regularly in order to avoid overflow.<sup>6</sup>

### 3.4 Composting and secondary treatment

- The composting process should always be enhanced by a mixture of various materials, like biodegradable garden or kitchen waste, grass or wood clippings, depending on availability<sup>7</sup>.
- The destruction of pathogens can be improved by piling up a compost heap of at least 1 m<sup>3</sup> and by covering of the compost heap against rain. This will prevent large heat losses and dehydration and improve self-heating of the material. However these measures will not be sufficient in cold climate. In literature one can find different information concerning the insulation of a composting heap depending on the climate zone<sup>8</sup>.
- When possible the optimum composting conditions should be achieved (moisture content, oxygen supply, C/N ratio, pH-value, biological activity, temperature).
- The heap should be turned after two weeks of heat development (> 55°C). The mixing will stimulate the composting process and the surface material of the compost heap will also be composted. Thereby another self-heating process will be activated.
- Regular composting as described can be used as a "post-composting measure" for material from simple separation toilets, dry toilets and dehydration toilets as well as for the material from vault systems.
- Other methods like vermi-composting by redworms or manure worms or long-term decomposition is useful, if high temperatures during a certain period cannot be achieved. In this case the compost shall only be used for ornamental plants or non-leafy food crops.



Figure 2. Brick chamber for faeces composting equipped with vent pipes on the back side and sheltered (photo: W. Berger, 2009 at German Research project at Valley View University, Ghana)

### 3.5 Application and reuse of compost

- Nutrient supply of the soil shall be determined before it is fertilised with compost (for example every ten years). An oversupply of the soil with nutrients should be avoided, particularly with regard to groundwater protection.
- Compost as a soil conditioner and fertiliser should be applied to plants during periods when plants need nutrients (such as during spring and autumn in European climates).
- Compost should be mixed with garden soil or sand to avoid over-fertilisation, before being applied to plants.
- Mixing the compost with topsoil is recommended. Compost should not be applied to deeper soil layers<sup>9</sup>.



Figure 3. Applying faeces compost to the garden soil by mixing with a pitchfork (source: Berger and Lorenz-Ladener, 2008).

<sup>6</sup> For further information see Germer et al. (2009b).

<sup>7</sup> To avoid fly infestation, organic waste from fermented fruits should not be added to the composting toilet, but be composted outside.

<sup>8</sup> The values for insulation are varying in a range of 75 mm styrofoam (in Uganda) to 200 mm styrofoam (in Sweden, see Vinneras et al. (2003)). In moderate climate zones insulation is recommended for small volumes (<1 m<sup>3</sup>) during year-round operation of the composting toilet. Even in moderate climate zones in a well operated composting process (with sufficient self-heating for pathogen removal), an insulation can be useful.

### 3.6 Hygienic precautions and directives

During cleaning, maintenance and handling of faeces compost, leachate and urine, it is recommended to use one-way rubber gloves and to wash hands afterwards. Only mature compost, which looks and smells like rich garden soil or leaf humus should be harvested and post-

<sup>9</sup> For further information see Germer et al. (2009a).

composted before reuse. Fresh material similar to the original waste material must remain in the vault for further composting.



Figure 4. Mature compost from a single-vault composting toilet ready for soil improvement (source: Berger and Lorenz-Ladener, 2008).

## 4 Single-vault composting toilets

### 4.1 Functional principles

Single-vault composting toilet systems contain and treat faeces, urine (if not diverted) and organic household waste together with bulking material. The basic process of the system is the decomposition of excreta inside one large container or vault.

The composting vault functions as a continuous reactor, with excreta being added to the top, and the end product (compost) being removed periodically from the bottom. Generally, the chamber is located beneath the toilet seat below the floor level. The large chamber allows long-term retention and facilitates aeration. Usually the floor of the chamber has a steep slope.

Excess liquid (leachate) flows down to a separate liquid storage chamber. Humidity is needed to maintain optimal composting conditions. With time, natural biological decomposition converts human waste into a small amount of stabilised soil-like material. Retention time is at least 2 years before the final compost (about 40 l per person per year on a household level) can be removed. Loose material flows by gravity or is pushed manually to the bottom of the chamber. Certain tools for further treatment inside the container can be used.

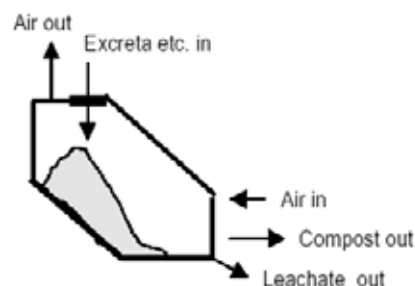

Figure 5. Flow chart of continuous composting toilet (source: Davison and Schwizer 2001)

#### 4.1.1 The Arborloo

An extremely simple, low cost version of the single vault composting toilet, the "Arborloo", has been developed for rural African regions (Morgan, 2007). The Arborloo dispenses with the need to remove the compost and instead uses a shallow pit with a depth of up to 1.5 m to collect and compost faeces, soil, wood ash and dry leaves. When the pit is almost full the contents are covered with a thick layer of soil. A young fruit tree is eventually planted within the pit. At the same time another shallow pit will be dug and the toilet superstructure moved to the new pit.

### 4.2 Operation and maintenance

Before starting operation, a layer of bulking, absorbing material (such as a mixture of biological active soil or compost and wood chips) should be filled into the compost container to provide a drainage base as well as a biological starter. On top of this layer, a cover of carbon-rich additives, such as sawdust, wood chips or straw clippings, dried leaves or rice hulls is placed and moistened.

Regular mechanical movement of the organic material is necessary to ensure the biological degradation process. An aeration stick or a pitchfork can be used for this purpose. If conditions support earthworms or other soil digging fauna, these may take over the role of shifting the material. Once the capacity of the vault has been reached, the compost at the bottom of the container must be removed regularly, at least once a year, in order to ensure enough space for the ongoing decomposition.

Emptying of the single vault toilet is less frequently needed than for multiple-vault systems. However, the weight of the larger mass of material can cause compaction. This requires increased maintenance to ensure good aeration. Regular maintenance is therefore very important to guarantee the correct performance of the system.

### 4.3 Extent of application

Single-vault composting toilets are the oldest and most common composting toilet models in many places worldwide. Typical applications of single-vault systems in industrialised countries include locations where there is no connection to a central sewer, such as in mountain huts, nature reserves or remote settlements. Single-vault composting toilets are also installed in many ecological settlements near urban surroundings.

Owner-built models, similar to the *Clivus Multrum model*, are very common in developing countries with warm

climates, and the simple Arborloo is also gaining in popularity, particularly in rural Africa. Urine diversion is generally recommended to minimise production of leachate and to prevent anaerobic conditions within the material due to the high water content.

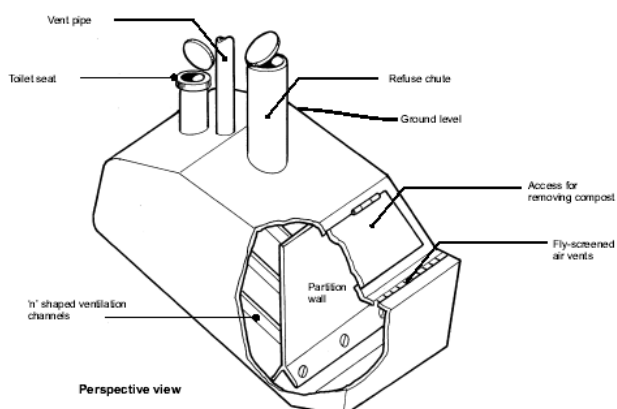

Figure 6. View of a single-vault composting toilet (source: Reed and Shaw, 1999).

#### 4.4 Hygiene (pathogen removal)

In a single vault composting toilet there is a risk that mature, sanitised material is mixed with fresh material, and thus again is being contaminated with pathogens. Professional system design like a separating wall between composting chamber and removal zone, and reliable and qualified maintenance is crucial to reduce that risk. If these two points cannot be guaranteed then a multiple vault system should be considered instead.

For the Arborloo, there is generally a low risk of exposure to either the compost or fresh faeces as these are covered and not removed from the shallow pit.

#### 4.5 Cost data

The prices for manufactured systems in Germany range from EUR 2,000 for a model used only seasonally to more than EUR 8,000 for a model for public use (see also suppliers' information in Appendix). When comparing prices of the different models, production conditions, environmental impact, life span, durability and transport expenses should be considered.

#### 4.6 Good practice examples

Examples include:

- In Hamburg, Germany, 36 composting toilets have been installed within the eco-settlement Allermöhe in 1986<sup>10</sup>, see Figure 7 below.
- An owner-built *Clivus Multrum*-style model was designed by The Resource Institute in Puerto Morelos community in Mexico (see Figure 8 and Figure 9 below). This project is called Nahi Xix. For more information see: <http://www.riles.org/projmex.htm>.



Figure 7. Left: Dry toilet with removable insert and sealed toilet seat. Right: Insulated single-vault composting container with upper lid for maintenance and lower lid for discharge and working platform (both Hamburg-Allermöhe, Germany, source: Berger and Lorenz-Ladener, 2008).



Figure 8. Owner-built toilet seat with storage for wood chips to cover the pile on a daily basis (Puerto Morelos, Mexico) (source: the ReSource Institute, <http://www.riles.org/projmex.htm>).



Figure 9. Owner-built single-vault composting toilet with built-in toilet connection and outside access for maintenance and discharge (Puerto Morelos, Mexico) (source: The ReSource Institute, <http://www.riles.org/projmex.htm>).

<sup>10</sup> For details see: <http://www.susana.org/lang-en/case-studies/region/europe>



## 5 Multiple-vault composting toilets

### 5.1 Functional principles

Multiple-vault composting toilets consist of two or more watertight, interchangeable chambers to collect excreta.

In multiple vault systems one vault is filled first and left to mature while another vault is brought into use. Urine can be diverted from the vault if required. Generally these toilets are not used to compost organic household waste due to their limited volume.

#### 5.1.1 Rotating multi-chamber

A multiple-vault toilet can be constructed from an underfloor processing vault with a cylindrical outer housing in which a slightly smaller inner tank is able to rotate. The inner tank is divided into four (or more) chambers (see Figure 10).

The vault in use is positioned directly below the down pipe of the toilet. When the vault in use is filled, the inner tank is rotated, whereby the next vault is positioned below the toilet. In this way each vault is filled in sequence. After filling all the vaults, the material in the first vault is removed and emptied through an access door.



Figure 10. Rotating multi-chamber bin (source: Ekolet, Finland).

Systems with four vaults allow the connection of two double vault toilets. Double-vault toilets function similarly: There are two vaults with one being used first. When the first vault is filled up, it is closed for further decomposition and the second vault is used. When the second vault fills up, the contents must be removed from the first vault, so the vault can be used again.

Proper dimensioning of the usable volume is needed to ensure that multi-vault composting toilets work correctly: the system shall work with sufficient time to allow for a sufficient maturation period of the stored material, before the vault in use fills up and has to be changed.

Usually these systems require a secondary (post-) composting in order to ensure sanitisation.

#### 5.1.2 Movable squatting plate

In specially designed double vault systems the toilet itself is movable. Usually these toilets are squat toilets with a movable squatting plate.

The squatting plate is placed above the vault in use, and has an opening for the faeces. At the same time the opening of the second, remaining vault remains covered by the squatting plate. Once the first vault is filled the squatting plate of the toilet is turned by 180°, whereby it closes the first vault and opens the second vault for further use<sup>11</sup>.

In toilets where urine is not diverted, liquid can drain into a collection tank by means of a sieve bottom or a slope. If not treated and used as a fertiliser, the leachate should be discharged into an evapotranspiration bed or a wastewater treatment process. The covering lids of the vaults can face the sun for additional heating. This increases evaporation of leachate as well as the temperature of the composting process.

#### 5.1.3 Fossa alterna

A low-cost double vault composting toilet, the “Fossa Alterna”, has been developed for rural Africa, which functions in exactly the same manner as more expensive systems, only that the composting vaults are shallow pits and the toilet superstructure is moved back and forth between the pits as they are used in alternation (Morgan, 2007).

### 5.2 Operation and maintenance

Small multiple-vault toilet facilities require careful monitoring of the level within the vault in use. The emptying frequency is generally higher than in single-vault systems. Maintenance, such as mixing of the material, is rarely required, as problems with compaction and anaerobic conditions are reduced through the smaller volume.

Emptying of the chambers may be more comfortable and acceptable to users or operators than in single-vault systems, as the material is completely separated from fresh faeces. However, by dividing the whole composting mass into several smaller parts, the decomposition process is not complete and not as good as in single vault-systems.

### 5.3 Extent of application

Larger multiple-vault systems are often constructed as outhouses separated from homes. Smaller systems can easily be integrated in homes, if proper ventilation is guaranteed.

### 5.4 Hygiene (pathogen removal)

Multiple-vault systems avoid the contamination of mature compost with fresh faeces. Therefore the release of pathogens into the environment can be reduced significantly compared to single-vault systems.

However the material is not fully composted and has to receive a secondary treatment (such as regular

<sup>11</sup> Alternatively, the vaults themselves may be moveable under a fixed toilet (see also Section 5) or a squatting plate with two holes can be used, whereby one hole always remains closed, while the other is used.

composting) before it is hygienically safe and can be used as a fertiliser in garden or agricultural areas.

The World Health Organisation recommends the use of multiple-vault toilets over single-vault toilets due to the increased protection through limited exposure to fresh excreta.

## 5.5 Cost data

Manufactured multiple-vault toilet systems are available in different units of varying capacity at prices between EUR 2,000 and 3,000 (Hyttetorget, Norway). Prefabricated double-vault toilet substructures made of fibreglass can be purchased between EUR 800 and 900 (Sirdo Seco, Mexico). For further information see suppliers' data in Appendix.

Running costs for multiple-vault systems are usually higher than for single-vault systems, due to the increased effort in managing the process. The benefit obtained from the product may be similar to other types of composting toilets. The double vault system can be self-constructed by using cement blocks and should be coated inside and outside for sealing. Vault size typically is about 1.2 m x 1.2 m for a total volume of 1.8 m<sup>3</sup> each.

## 5.6 Good practice examples

### 5.6.1 Example 1 – Sirdo Seco

The Sirdo Seco toilet system is divided into two vaults inside a composting container, equipped with a sliding baffle between the toilet chute and the dividing wall of the two vaults. When one vault is filled, the baffle is switched by a handle, causing the excreta to slide into the other vault. Each vault has a volume of 1.2 m<sup>3</sup>. If 6-8 people use it regularly, it needs to be emptied once a year at most.

A ventilation pipe from the container to the roof top removes odours and has a screen on top to prevent flies from entering or leaving the system. Both vaults are covered with lids made from black painted aluminium sheet, to increase evaporation by heating faecal matter.

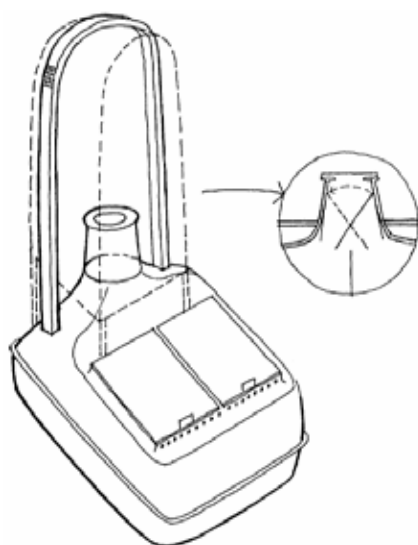

Figure 11. Sirdo Seco double-vault toilet in Mexico (source: Winblad and Simpson-Hebert (2004)).

The Sirdo Seco has been used in Mexico for over 20 years. One particular advantage is its low weight construction when empty. When people living in squatter

settlements are evicted at short notice, they can empty the toilet and simply take it with them.

### 5.6.2 Example 2 – Pacific Island CCD toilet

The Pacific Island Center for Clean Development (CCD) toilet is being applied in the south pacific islands and consists of two watertight chambers built above the ground. Excreta falls on a mat woven from coconut palm fronds resting on top of a nylon fishing net that is suspended inside the composting vault to separate solid from liquid excreta. This false floor allows air to penetrate the compost pile from all sides (see Figure 12).

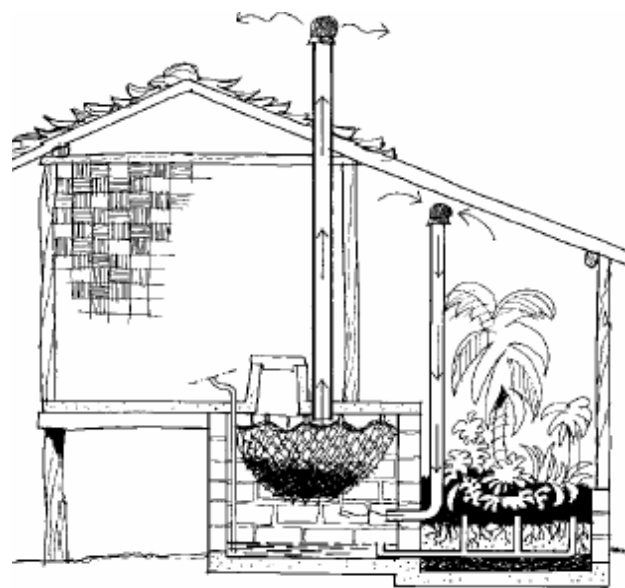

Figure 12. Cross section of the CCD composting toilet with attached greenhouse and evapo-transpiration bed (source: Winblad and Simpson-Hebert (2004)).

A large diameter vent pipe draws air from an intake opening located below the net along the rear wall of the vault. This airflow also helps to evaporate the liquids that accumulate on the floor of the digestion vault.

Evaporation is further enhanced by wicks made from stripes of polyester or rayon fibre (from old clothing), which are hung from the net to draw up the liquid from below, increasing the surface area exposed to the air stream.

Another solution is to drain the liquid to an evapotranspiration bed. Experiences with CCD toilets on the island of Pohnpei, Federated States of Micronesia, have shown that it takes a family of up to 10 people over a year to fill one composting vault. The solids in the vault have undergone biodegradation and all excess liquids had been evaporated.

## 6 Mobile bucket or bin toilets followed by composting of the excreta

### 6.1 Functional principles

Movable bucket or bin toilets are not composting toilets but they are containers for excreta collection. They can

function either as alternating removable buckets or as powered roll-away containers with quick-disconnect couplings for toilet, exhaust and leachate drain connection. Some systems use commercially available roll-away “wheelie” bins, some use any kind and size of buckets, equipped with a lid and a handle to carry by hand. Composting does not occur within the receiving container.

The bucket or bin toilet should become part of a composting system. The relatively fresh excreta must be removed regularly for composting on an external compost heap or in a compost bin.

One container (bin or bucket) is placed under the toilet seat or toilet chute and is replaced when full. The content in the first bin is further stored for treatment either:

- on-site – such as in a compost pile, composting container, or by fermentation, or
- off-site – in a composting or biogas plant.

Some systems use urine diversion; others collect both urine and faeces in bins that usually need absorbing additives and have a drainage system for leachate.

Other systems that can also be classified as movable bin systems, are compact dry toilets that collect faeces and sometimes also urine in small receptacles integrated in the toilet unit. Receptacles may also be simple plastic or biodegradable bags.

Most of the toilet models are equipped with a ventilation system in order to prevent odour and improve evaporation. The ventilation system operates either by natural negative pressure or by electrical power.

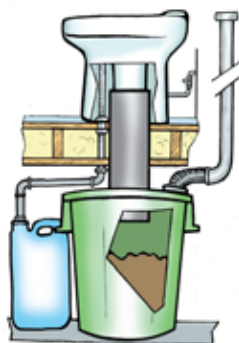

Figure 13. Urine diverting dry toilet with bucket under floor (source: Wostman Ecology AB, Sweden)

## 6.2 Operation and maintenance

The collection bins and buckets need to be regularly emptied and replaced. Biodegradable bags can be used as a liner in order to avoid the need to clean the containers after emptying. These biodegradable bags are comfortable and hygienic and last several weeks for the collection of faeces, if urine is diverted.

Treatment is most often carried out in a compost heap or bin on site. Several advanced composters, handling options, turning tools and measuring instruments are offered by specialised suppliers. For further treatment

instructions see Section 3.4. Urine or leachate needs to be handled, stored and treated for reuse<sup>12</sup>.

## 6.3 Extent of application

Toilets with movable buckets and a small capacity are available for non-permanent use such as holiday homes or allotment garden. Due to their small size, they are self-contained and do not require the larger vault associated with single or even multiple-vault systems.

The emptying frequency is much higher and there is a need for on-site or near-to-site composting facilities. This may hinder acceptance, if user frequency is high and users themselves are responsible for emptying the collection bin and subsequent composting.



Figure 14. Movable bucket toilet for the addition of sawdust or bark chips. Exchangeable buckets and biodegradable bags can be used (source: Berger Biotechnik, Germany)

The larger bin system would be best suited to large-scale operations, where a pick-up service empties the bins and transports the contents to a central or semi-central treatment facility.

Emptying and treatment of the excreta would no longer be part of the user's responsibility, unlike in some other composting toilets. A degree of comfort - somehow comparable with conventional flush toilets - would be provided and could therefore create a higher level of acceptance.

The treatment of the collected excreta will be done in larger external units, whereby the decomposition process can be controlled and optimised constantly. Eventually this will result in a higher quality of the final product compost.

<sup>12</sup> Urine is usually easier to handle than leachate, as the contamination with pathogens is much lower.

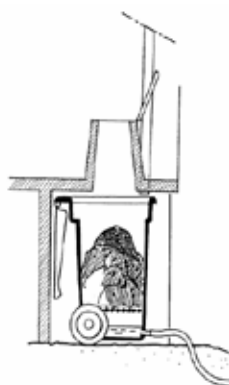

Figure 15. Schematic diagram of movable bin composting toilet (source: Winblad and Simpson-Hebert (2004)).

#### 6.4 Hygiene (pathogen removal)

Full collecting bins or buckets have to be closed securely with lids to avoid any accidental spill of faecal matter or odour during transport and intermediate storage before the final treatment. Further adequate protection measures during handling of the contents shall be guaranteed in order to minimise health risks of users and service staff. Additives (absorptive bulking material) can help to absorb odour. Additives such as bark and wood chips are necessary if ventilation of the collecting container is not possible.

Composting and inactivation of pathogen germs does not occur within the collecting containers. Therefore a correct composting process is absolutely essential before the organic matter is used on plants. If the content of the bins is collected and treated centrally in a composting plant, a high quality and hygienically harmless compost can be produced.

#### 6.5 Cost data

The collection system of mobile bucket toilet systems can easily be constructed by the users themselves. Most material and even second-hand bins and buckets are locally available and can be modified to be used as a collection container.

Specifically manufactured bins with connections for ventilation and leachate drainage are more expensive but still much cheaper than single or multi-vault composting toilets. Costs for manufactured bucket toilets range from EUR 50 - 250, and for bin toilets with higher capacity from EUR 200 to 600. Cost savings may be obtained in larger schemes with a collection system and a central treatment plant.

The collecting container however is only one part of the complete composting toilet system and a composting facility with restricted access to minimise exposure will be required to ensure treatment. This will add some additional costs.

Benefits obtained from this system after treatment may be higher than for other compost toilet models due to the lower investments<sup>13</sup>. Central co-composting with domestic organic waste may be an economically reasonable solution in densely populated areas, if there is a local demand for compost.

<sup>13</sup> Only if the extra efforts for operation and treatment are not counted.



Figure 16. Movable ventilated collecting bins with overflow for leachate discharge (source : PikkuVihreä, Finland).

#### 6.6 Good practice examples

##### 6.6.1 Example 1 – Kiribati, Central Pacific

An example in Kiribati uses two 240 litre standard wheeled plastic refuse bins for collection. There is a false floor of mesh near the base of each bin, which allows liquid to drain to the base. The bin is equipped with an overflow-pipe and connected to a sealed evapotranspiration bed.

Ventilation of the bin is ensured through a cut-out near the base, which supplies fresh air to the material through the mesh-floor. In addition, perforated ventilation pipes running vertically along the inside walls of the bin help to aerate the pile. For further information please refer to : <http://www.unep.or.jp/ietc/publications/techpublications/techpub-8d/kiribati2.asp>

##### 6.6.2 Example 2 – Erdos Eco-Town, Dong Sheng, China

The Erdos Eco-Town project in Dong Sheng, Inner Mongolia, China, was the largest project worldwide with composting bin toilets<sup>14</sup>. The project was supported by the Swedish government and covered more than 800 households in 4-storey buildings. The urine diverting dry toilets were specially designed for this project and were made of sanitary ware. Each toilet was equipped with a “flushing” device for sawdust and a turning bowl to prevent people from seeing into the down pipe.

The down pipe was connected to an individual collection bin in the basement of the buildings. Trained staff members were responsible for the information and consultation of users as well as maintenance and collection of faeces. The treatment of the collected matter in the local eco-station (including composting of faeces, grey water treatment and solid waste sorting) was also in the responsibility of the service staff.

<sup>14</sup> For detailed information, please refer to the initial project description: [http://www.ecosanres.org/pdf\\_files/ESR-factsheet-11.pdf](http://www.ecosanres.org/pdf_files/ESR-factsheet-11.pdf)





Figure 17. Part view of the multi-story houses in Dong Sheng, showing vent pipes on the roof from the ventilation system (photo : W. Berger, 2009).

Although generally successful, long-term experiences in operation and maintenance have shown that improvements in planning, construction and realisation were necessary. Investments for optimisation measures should have been implemented right from the start of this pilot project.

Because of the serious deficiencies causing immense efforts for retrofitting, the dry toilets will eventually be substituted by low-flush toilets. In this regard the project offers a wide area for lessons learnt.



Figure 18. Left : Ceramic urine diverting dry toilet equipped with faeces turning bowl and odour trap for urine. Right : Downpipes coming from each floor leading into separate bins with housing (Erdos Eco-Town, Dong Sheng, China, photos: W. Berger, 2009)

### 6.6.3 Example 3 – Gebers housing project, Stockholm, Sweden

The Gebers collective housing project near Stockholm, Sweden, consists of apartment buildings for 80 inhabitants. This project served as a model for the Erdos project in China. There are dry toilets with urine diversion in each apartment.

Urine is collected in a tank in the basement and is reused in agriculture after further external storage. Faeces fall straight down through pipes into ordinary 140 l dust bins in the basement. The bins are removed when full and transported to a nearby composting site.

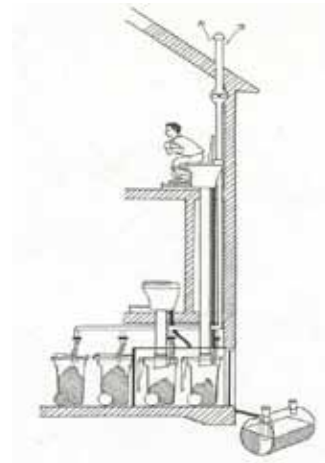

Figure 19. Sketch of the movable bin system at Gebers apartment block in Stockholm, Sweden (source: Winblad and Simpson-Hebert (2004).

For further information see the project data sheet: <http://www.gtz.de/de/dokumente/en-ecosan-pds-008-sweden-gebers-2005.pdf>.

## 7 Composting toilets with mechanical devices

### 7.1 Functional principles

Several manufacturers offer technically sophisticated designs, equipped with mechanical devices and electrical heaters, to speed up evaporation and degradation. The devices help to increase capacity or minimise space and to simplify maintenance.

The basic principle of most of these toilets is to mix faecal matter with sawdust or a similar organic material, by turning or stirring devices located inside the vault. Intermittent moving improves aeration, intensifies the contact with microorganisms in the matrix and thus increases the decomposition of the content.

The mixing device can be mechanically driven and operated by hand or foot, (e.g after each use) or electrically driven and activated by pressing a button or automatically by sensors. Continuous ventilation is necessary to prevent odour and to ensure air exchange.

Many systems can also handle urine, but more carbonic absorbing material and heating energy is needed to manage the excess liquid, if it is not drained. Evaporation of liquids through heat may be preferable in climates with cold temperatures.

Urine diversion allows for the construction of smaller systems. However the moisture content of the material must be observed either with or without urine diversion, to prevent sludge accumulation or crustification within the system. Stirring devices are generally also advantageous for dehydration processes of faecal matter.



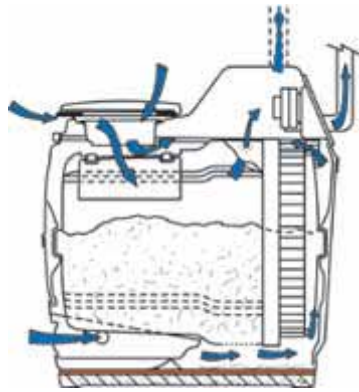

Figure 20. Cross section of turning drum facility with enforced ventilation (source: Sun-Mar, USA)

## 7.2 Operation and maintenance

Handling and maintenance requirements depend on whether batch or continuous systems are used.

In batch systems, composting bins are filled with sawdust or similar charge materials before use. During operation, no further additives are needed, but the condition of the mixture should be checked regularly to make sure that it does not dry up or get too wet.

After being filled and a further decomposition period of at least 6 months, the bin should be emptied completely. A new load of charge material is put into the bin to start another filling. Batch systems, each equipped with mechanical and electric devices, mostly run in a large scale setup.

Continuous systems are filled with a layer of biodegradable charge material (such as sawdust) before the first use. However, some additives need to be supplied regularly for proper operation.

The system enables a regular extraction of small volumes of mature compost at frequent intervals (for example once a month), while fresh material remains in the treatment chamber for further processing. The final product of both systems should undergo a second treatment before being applied to the soil as soil conditioner and fertiliser.

## 7.3 Extent of application

System sizes vary from small individual models that can be installed for example in a private bathroom to large models for public toilets or even for processing organic waste from industries. Power supply is needed in most systems for heating, mixing devices and ventilation. Connections for ventilation, a storage tank<sup>15</sup> or a pipe connection for further treatment may be required.

<sup>15</sup> A storage tank is only necessary if excess liquid is discharged or urine diversion is provided.

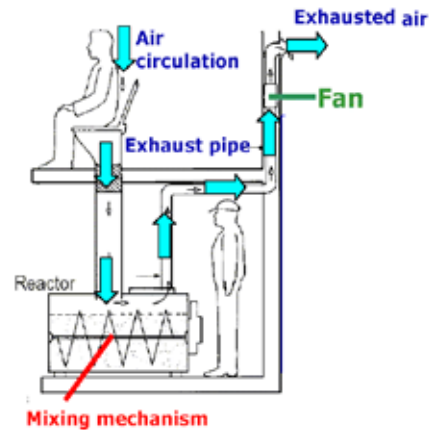

Figure 21. Cross section of a toilet facility with horizontal stirring unit (source: Seiwa Denko, Japan)

### 7.3.1 Large Systems

Large systems such as the larger versions of the Japanese BioLux (see appendix: Range of manufacturers and commercially available composting toilets) are usually detached from the toilet and located beneath bathrooms or toilet cabins. A volume of 1 m<sup>3</sup> of sawdust is required for 150 to 200 users per day.

Systems that process urine together with faeces require much more energy for the evaporation of excess liquid than systems with urine diversion. Systems with urine diversion require heating only for the maintaining of an optimal temperature for the composting process.

### 7.3.2 Small Systems

Small systems, such as the Scandinavian Biolan Naturum or the Biolet (see appendix: Range of manufacturers and commercially available composting toilets), are designed for a small number of users.

They are very compact and can be installed in bathrooms of individual houses or allotment gardens for non-permanent operation.

The systems use continuous processing and are available with mechanical or electrical mixing devices, both with or without heating systems. Urine is diverted and collected separately.

In general the application of prefabricated automatic or semi-automatic toilet systems is usually limited to industrialised countries due to their relatively high cost and the difficulty to reproduce, maintain and repair them easily on a local level.

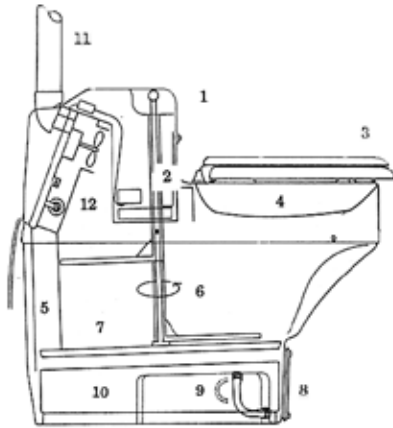

Figure 22. Cross section of a compact toilet with vertical stirring unit (source: Biolet USA/Switzerland)

#### 7.4 Hygiene (pathogen removal)

Systems that are equipped with heating devices to evaporate urine and/or to maintain optimum conditions for composting and pathogen destruction may achieve pathogen-free material. The process is controlled by thermostats to guarantee a constant temperature above 50 to 60°C.

However, the final product may be too concentrated with salts and nutrients, so mixing with poor soil and post-composting is recommended.

Also systems without permanent operation conditions may require further treatment of the material for safe reuse.

#### 7.5 Cost data

Composting toilets with mechanical devices are usually more expensive than other types of manufactured composting toilets. Investment costs and operational costs are higher due to expensive technical components, the higher need for repairs and the energy demand. Systems that evaporate urine have high electricity consumption.

Urine diversion lowers the high energy demand. The use of mixing devices reduces manual maintenance needs.

Efforts for post-treatment or other safety measures before reuse of compost are lower than in many other types of composting toilets, as the hygienic quality is higher due to controlled composting conditions.

The systems may optimise the composting process and minimise user involvement. As far as power supply is available, they can be used in situations, when other composting systems cannot be applied.

#### 7.6 Good practice example

Asahiyama Zoo, located in the northern part of Japan, attracts thousands of visitors every month. Since 1997, a total of 12 composting toilets (BioLux) have been installed. Almost all units treat both faeces and urine together and few treat urine only.

Survey results showed that the system had gained great acceptability not just by the staff of the zoo, but especially by the users. As a result, the management is planning to use the system to treat animal wastes as well (Asahiyama Zoo, Kuranuma, Higashi Asahikawa-cho, Asahikawa City, Japan).

For further reading see:

<http://www.gtz.de/en/dokumente/en-ecosan-pds-030-automated-compost-toilet-asahiyama-zoo-2006.pdf>

## 8 References

### 8.1 References used in this publication

Berger, W. and Lorenz-Ladener, C. (eds.) (2008) *Komposttoiletten – Sanitärtechnik ohne Wasser* (Composting toilets – sanitary technology without water). Ökobuch-Verlag, Staufen, Germany (in German). Table of contents is available here:

<http://www2.gtz.de/Dokumente/oe44/ecosan/de-TOC-ONLY-kompost-toiletten-ohne-wasser-2008.pdf>

Davison, L. and Schwizer, B. (2001) *Waterless composting toilets*. Septic Safe, Environment & Health Protection Guidelines: On-site Sewage Management for Single Households, Perth, Australia.

[http://www.clearwater.asn.au/resources/523\\_1.322\\_TD\\_JW\\_DavisonCompostingtoilets.pdf](http://www.clearwater.asn.au/resources/523_1.322_TD_JW_DavisonCompostingtoilets.pdf)

Morgan, P. (2007) *Toilets That Make Compost*. EcoSanRes, Stockholm Environment Institute, Stockholm, Sweden.

[http://www.ecosanres.org/pdf\\_files/ToiletsThatMakeCompost.pdf](http://www.ecosanres.org/pdf_files/ToiletsThatMakeCompost.pdf)

Reed, B. and Shaw, R. (1999) *Using Human Waste*. Water and Environmental Health at London and Loughborough, Technical Brief No. 63, London, UK.

<http://www.lboro.ac.uk/well/resources/technical-briefs/63-using-human-waste.pdf>

UNICEF and WHO (2008) *Progress on drinking water and sanitation: special focus on sanitation*. UNICEF, New York and WHO, Geneva.

[http://www.who.int/water\\_sanitation\\_health/monitoring/jmp2008/en/index.html](http://www.who.int/water_sanitation_health/monitoring/jmp2008/en/index.html)

Richert, A., Gensch, R., Jönsson, H., Stenström, T.-A. and Dagerskog, L. (2010) *Practical Guidance on the Use of Urine in Crop Production*, Stockholm Environment Institute, EcoSanRes Series, 2010-1, [www.ecosanres.org](http://www.ecosanres.org)

Vinnerås, B., Björklund, A., Jönsson, H. (2003) *Thermal composting of faecal matter as treatment and possible disinfection method – Laboratory-scale and pilot-scale studies*. *Bioresource Technology* 88, 47-54. Abstract available here:

<http://linkinghub.elsevier.com/retrieve/pii/S0960852402002687>

v. Münch, E. and Winker, M. (2009) *Technology review on urine diversion - Overview of urine diversion components such as waterless urinals, urine diversion toilets, urine storage and reuse systems*. Deutsche Gesellschaft für Technische Zusammenarbeit (GTZ) GmbH, Eschborn, Germany. <http://www.gtz.de/en/themen/umwelt-infrastruktur/wasser/9397.htm>

WHO (2006) *Guidelines for the safe use of excreta and greywater*. World Health Organisation, Geneva, Switzerland.

[http://www.who.int/water\\_sanitation\\_health/wastewater/gsuww/en/index.html](http://www.who.int/water_sanitation_health/wastewater/gsuww/en/index.html)

Winblad, U. und Simpson-Herbert, M. (2004) Ecological Sanitation, Stockholm Environment Institute, Stockholm, Sweden.

[http://www.ecosanres.org/pdf\\_files/Ecological\\_Sanitation\\_2004.pdf](http://www.ecosanres.org/pdf_files/Ecological_Sanitation_2004.pdf)

## 8.2 References for further reading

Albinh, A., Vinnerås, B. (2007) Biosecurity and arable use of manure and biowaste – Treatment alternatives. *Livestock Science* **112**, pp. 232-239. Abstract available:

[http://www.journals.elsevierhealth.com/periodicals/livsci/article/S1871-1413\(07\)00473-8/abstract](http://www.journals.elsevierhealth.com/periodicals/livsci/article/S1871-1413(07)00473-8/abstract)

Del Porto, D. and Steinfeld, C. (2000) The Composting Toilet System Book: A Practical Guide to Choosing, Planning and Maintaining Composting Toilet Systems. ISBN-10 0966678303, CEPP, Concord, MA, USA.

Élain, C. (2005) Un petit coin pour soulager la planète (A little corner to relief the planet). ISBN-10 2953087702, Éditions Goutte de Sable, Athée, France (in French).

Franken, M. (2007) Gestión de aguas, Conceptos para el nuevo milenio (Water management – concepts for the new millenium). Plural editors, La Paz, Bolivia (in Spanish).

Funamizu, N. (2006) Dry Toilet: An Important System for Controlling Micro-pollutants from Our Daily Life. Proceeding from the 2nd International Dry Toilet Conference, 16-19 August 2006 in Tampere, Finland. [http://www.drytoilet.org/pdf/DT06\\_Final\\_Summary.pdf](http://www.drytoilet.org/pdf/DT06_Final_Summary.pdf)

Germer, J., Addai, S., Sarpong, D. (2009a) Small Scale Composting of Human Faeces. Nutshell Guideline 001. <http://www2.gtz.de/Dokumente/oe44/ecosan/en-small-scale-composting-of-human-faeces-2009.pdf>

Germer, J., Berger, W., Sarpong, D. (2009b) Maintenance of Public Urine Diverting Toilets. Nutshell Guideline 003. <http://www2.gtz.de/Dokumente/oe44/ecosan/en-maintenance-of-public-urine-diverting-toilets-2009.pdf>

GTZ (2006) Manual de compostaje municipal - Tratamiento de residuos sólidos urbanos (Manual for municipal composting – Treatment of solid urban waste). Ciudad de México, Mexico (in Spanish) <http://bav.agenciaambiental.gob.ar/repositorio/files/varios/compsmuni.pdf>

Harper, P. and Halestrap, L. (1999) Lifting the Lid, An Ecological Approach to Toilet Systems. ISBN-10 1898049793, C.A.T Publications, Machynlleth, UK.

Jenkins, J. (1999) The Humanure Handbook - A Guide to Composting Human Manure. Jenkins Publishing, Grove City, PA, USA. [http://humanurehandbook.com/downloads/Humanure\\_Handbook\\_all.pdf](http://humanurehandbook.com/downloads/Humanure_Handbook_all.pdf)

Kunst, S., Kruse, T., Burmester, A. (2002) Sustainable Water and Soil Management. ISBN-10 3540424288, Springer Verlag, Berlin, Germany.

Peasey, A. (2000) Health Aspects of Dry Sanitation with Waste Reuse. Water and Environmental Health at London and Loughborough. Task No. 324. London, UK.

<http://www.lboro.ac.uk/well/resources/well-studies/full-reports-pdf/task0324.pdf>

Schönning, C. and Stenström, T. A. (2004) Guidelines on the Safe Use of Urine and Faeces in Ecological Sanitation Systems. EcoSanRes Publications Series 2004-1, Stockholm Environment Institute SEI, Stockholm, Sweden. [http://www.ecosanres.org/pdf\\_files/ESR-factsheet-05.pdf](http://www.ecosanres.org/pdf_files/ESR-factsheet-05.pdf)

Van der Ryn, S. (1978) The Toilet Papers - Recycling Waste and Conserving Water. ISBN-10 1890132586, Ecological Design Press, Sausalito, California, USA.

Vinnerås, B. (2007) Comparison of composting, storage and urea treatment for sanitising of faecal matter and manure. *Bioresource Technology* **98**, 3317-3321. Abstract available here:

<http://linkinghub.elsevier.com/retrieve/pii/S0960852406003002>

## 9 Appendix: Range of manufacturers and commercially available composting toilets

A list of suppliers of (engineered) composting toilets with costs is provided in a separate file (to keep the file size of this document down), see here:

<http://www.gtz.de/en/dokumente/gtz2009-technology-review-composting-toilets-appendix.pdf>