



Cleaning hand-dug wells

Flooding, earthquakes, civil unrest and other natural and man-made disasters often cause damage to hand-dug wells. This technical note sets out the actions needed to repair and rehabilitate a hand-dug well so that it can be returned to its former condition. The emergency repair and rehabilitation measures proposed are temporary and should be followed by measures for permanent rehabilitation.

Steps for cleaning

Figure 1.1 outlines a four-step approach to cleaning a wells after natural or man-made disasters. It is an emergency approach designed to rehabilitate wells so that they produce water of a similar quality to that supplied before the disaster (see Box 1.1).

Technical Note 15 gives further information on wells contaminated by seawater.

Step 1: Inventory of existing wells

The disaster may have contaminated or damaged a large number of wells. The first step must be to select which wells should be repaired first. They are the ones that are used most and that are easiest to repair. The following actions should help you to make an informed selection.

- Meet with community leaders and ask them which wells serve each section of the community.
- Select the most commonly used wells as a source for drinking-water that provided a plentiful supply.
- Check there are no obvious sources of contamination from nearby latrines, ponds or surface water. Also map livestock areas (pig pens, cattle sheds, chicken coops) as potential sources of contamination by animal waste.
- Assess the type and extent of damage to the top of the well and the lining.
- Ask the community about the original depth of the well. Use this to estimate the amount of silt and debris in the well.
- Test the pump (if there is one) to see if it is still working. If not, determine the repairs necessary.
- Estimate the resources needed for repairs (personnel, equipment, time and materials).

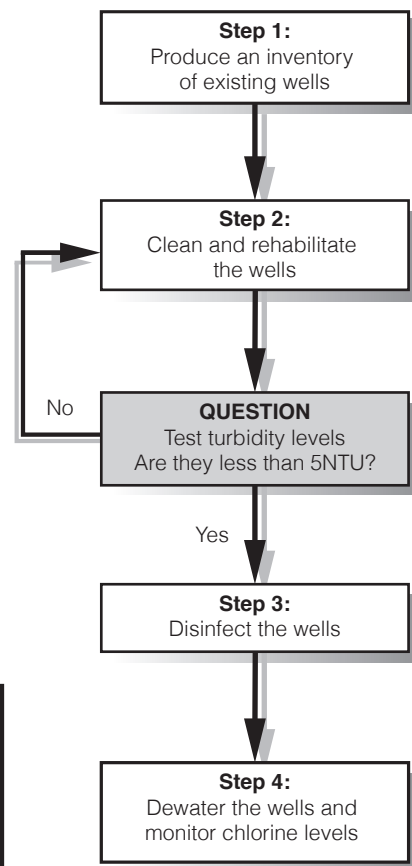

Figure 1.1. Steps for cleaning and disinfecting wells

Box 1.1. Hand-dug wells water quality

Water taken from hand-dug wells is often of poor quality, mainly due to the poor construction of the above-ground elements and unhygienic methods of collecting water. The steps described here will not overcome these problems as they are designed to return the well to its original condition. Sources of further information on improving and upgrading wells are given on page 1.4.

Step 2: Rehabilitation and cleaning of wells

The amount of rehabilitation and cleaning required will depend on the amount of damage caused by the disaster. Typically it will include the following steps:

1. Remove and repair/replace the pumping mechanism or lifting device.
2. Remove polluted water and debris from the well using either buckets or pumps. Special care must be taken when using a pump to remove water from wells contaminated with seawater. (See Technical Note 15 for more details.)
3. Repair/reline the well walls to reduce sub-surface contamination.
4. Clean the well lining using a brush and chlorinated water (see Box 1.2).
5. Place a 150mm layer of gravel in the base of the well to protect it from disturbance.
6. Seal the top of the well using a clay sanitary seal (Figure 1.2).
7. Construct a drainage apron and head wall around the well to prevent surface water, insects and rodents from entering the well. Provide a cover for the well.

Check turbidity and pH

Following cleaning and repair, allow the water level in the well to return to its normal level. Measure the turbidity and pH levels to check whether chlorination will be effective. This can be done using a simple method described in Box 1.3.

Never chlorinate turbid water because suspended particles can protect micro-organisms. Table 1.1 (page 1.4) outlines the reasons why pH and turbidity are important and what can be done to ensure guideline levels are met.

If the turbidity of the well water is greater than 5NTU after the cleaning and rehabilitation stage, remove all water in the well once again.

Box 1.2. Calculating the chlorine dosage for disinfecting a well using high strength calcium hypochlorite (HSCH)

Equipment

- 20 litre bucket
- HSCH chlorine granules or powder

Method

- Calculate the volume of water in the well using the formula:

$$V = \frac{\pi D^2 h}{4}$$

Where

- V = volume of water in the well (m³)
- D = diameter of the well (m)
- h = depth of water (m)
- π = 3.142

- Fill the bucket with clear water from the well.
- Add about 300g of HSCH and stir until dissolved.
- For every cubic metre (m³) of water in the well add 10 litres (half bucket) of the chlorine solution.
- Double the quantity of HSCH added if the solution is to be used for cleaning well linings or aprons.

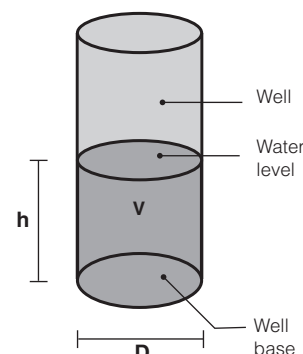

HSCH and bleach give off chlorine gas which is a serious health hazard. Try to clean the well lining from outside the well using a long-handled brush. If you must enter the well, wear full protective clothing and a breathing apparatus and provide a strong air flow inside the well to carry away the chlorine gas.

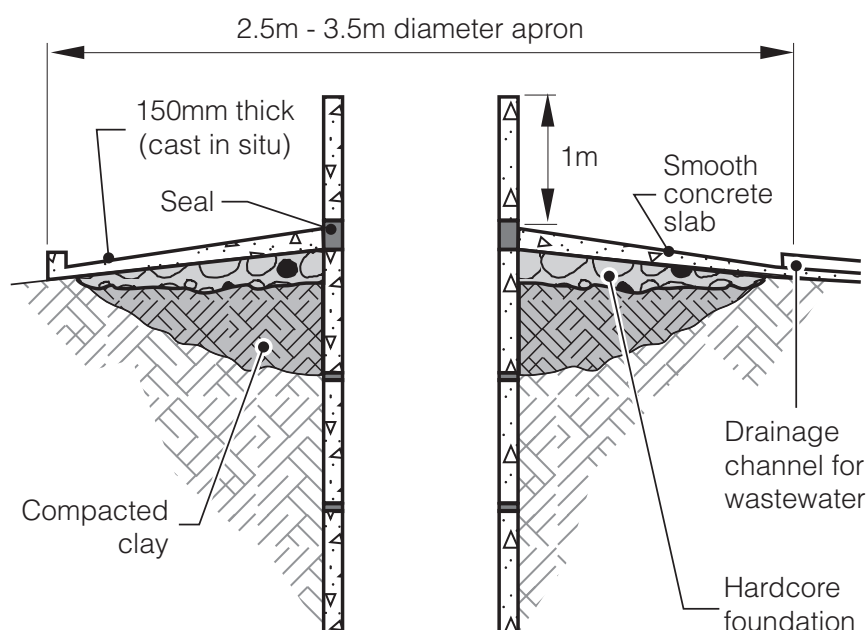

Figure 1.2. Sealing the top of a well

Allow the well to refill with water and test the turbidity levels again.

If the water is still turbid, it is probably due either to:

- the failure of the filter pack in the bottom and around the side of the well; or – more likely –
- to poor protection of the top of the well allowing surface water contamination.

Neither of these problems can be solved immediately. However, it is probably safe to allow the local community to begin using the well as the water quality should be at least as good as it was before the disaster.

Step 3: Disinfection of the well

Before water is extracted from the well for consumption, disinfection is recommended to ensure well components are hygienically clean. Such disinfection will *not* provide residual protection and therefore measures to ensure safe collection, handling and storage at home are highly recommended. This may include use of household water treatment. Please see Note 5 for details.

Chlorine has the advantage of being widely available, simple to measure and use, and it dissolves easily in water. Its disadvantages are that it is a hazardous substance (to be stored and handled with care) and it is not effective against some pathogens (i.e. it will not remove *cryptosporidium*, a cyst that causes a considerable proportion of diarrhoeal disease worldwide).

The chlorine compound most commonly used is High Strength Calcium Hypochlorite (HSCH) in powder or granule form as it contains 60 – 80% chlorine. Also used is sodium hypochlorite in liquid bleach or bleaching powder form. Each chlorine compound has a different amount of usable chlorine depending on the quantity of time the product has been stored or exposed to the atmosphere and the way it is made. Box 1.2 outlines methods for

Box 1.3. Measuring turbidity and the pH level of water

Turbidity is the cloudiness or haziness of a fluid caused by individual particles. The measurement of turbidity, therefore, is a key test of water quality. Specialist laboratory or field equipment (a nephelometer) is required to measure turbidity accurately in Nephelometric Turbidity Units (NTU). If you do not have access to such specialist equipment, then a reasonable NTU estimate can be made using locally available materials as shown below.

Equipment

- A clean container with a dark-coloured interior surface – such as an oil drum or a dustbin – and with a minimum depth of 50cm
- A bucket
- A dull brass or copper coin with an approximate diameter of 2.5cm
- A long measuring pole or steel tape measure

Method

1. Place the coin in the bottom of the container.
2. Gently add water drawn from the well a little at a time (a). At regular intervals, wait for the surface of the water to calm and check to see if the coin is still visible (b). When it can no longer be seen (c), measure the depth of the water (d).
 - If the depth of the water is *less than* 32cm, then the turbidity is likely to be *greater than* 20NTU.
 - If the depth of the water is between 32 and 50cm, then the turbidity is likely to be between 10 and 20NTU.
 - If the depth of the water is *greater than* 50cm, then the turbidity is likely to be *less than* 10NTU.
3. Measure the pH level of the water using pH paper strips (e).

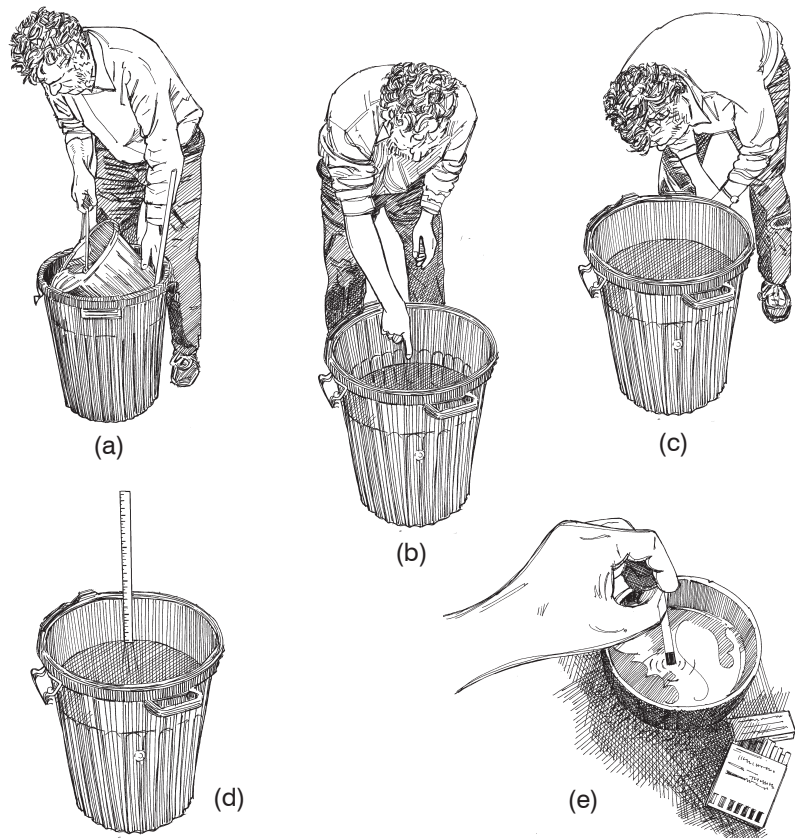

Cleaning hand-dug wells

calculating appropriate chlorine doses for HSCH granule chlorine. Stir the water in the well thoroughly with a long pole and then allow the water to stand for at least 30 minutes.

Step 4: Dewater the well

Following the contact period, remove all water in the well using a pump or bucket. When the well has refilled, wait a further 30 minutes and measure the chlorine concentration. If the residual chlorine concentration is less than 0.5 mg/l it is likely that the well has been restored to its original condition. It does not mean, however, the water is safe for drinking. If the concentration is greater than 0.5mg/l, remove all the water from the well again and repeat the process.

Two issues need extra care when dewatering the wells:

- 1) water with high concentration of chlorine should not flow into streams or wetlands;
- 2) when dewatering on coastal areas salt water intrusion should be avoided (see Technical Note 15).

Table 1.1. Physico-chemical parameters

Parameter	WHO GDWQ*	Why?	Corrective action
pH	6-8	pH of 6.8-7.2 is required to reduce level of chlorine required.	If pH is less than 6 add hydrated lime (calcium hydroxide) to raise pH before chlorination
Turbidity	< 5NTU	High turbidity requires more chlorine to oxidise organic matter	Check the turbidity of the water entering the well through the walls and base. Make sure there is no contamination from the surface.

*WHO Guidelines for drinking water quality

Do not allow anyone to use the well during the cleaning process.

The water will have a strong concentration of chlorine that will give it a bad taste and smell and could be dangerous.



Further information

CDC (Undated) *Disinfection of wells following an emergency*. Centre for Disease Control and Prevention. USA.
<http://emergency.cdc.gov/disasters/wellsdisinfect.asp>

Collins, S. (2000) *Hand dug wells*. Series of Manuals on Drinking Water Supply Vol. 5.

Godfrey, S. (2003) 'Appropriate chlorination techniques for wells in Angola', *Waterlines*, Vol. 21, No. 5, pp 6-8, ITDG Publishing, UK.

OXFAM (Undated) *Repairing, cleaning and disinfection of hand dug wells*. http://www.oxfam.org.uk/resources/downloads/emerg_manuals/draft_oxfam_tech_brief_wellcleaning.pdf

SKAT: St Gallen <http://www.rwsn.ch/documentation/skatdocumentation.2005-11-14.6529097230/file>

WHO (2011) *WHO Guidelines for Drinking-water Quality*, 4th edition. World Health Organization, Geneva.

WHO (2013) 'How to measure residual chlorine in water'. Technical Note 11

WHO (2013) 'Cleaning wells after seawater flooding'. Technical Note 15



World Health Organization

Water, Sanitation, Hygiene and Health Unit
 Avenue Appia 20
 1211 Geneva 27
 Switzerland

Telephone: + 41 22 791 2111
 Telephone (direct): + 41 22 791 3555/3590
 Fax (direct): + 41 22 791 4159
 URL: www.who.int/water_sanitation_health

Prepared for WHO by WEDC. Authors: Sam Godfrey and Bob Reed. Series Editor: Bob Reed.
 Editorial contributions, design and illustrations by Rod Shaw
 Line illustrations courtesy of WEDC / IFRC. Additional graphics by Ken Chatterton.

Water, Engineering and Development Centre Loughborough University Leicestershire LE11 3TU UK
 T: +44 1509 222885 F: +44 1509 211079 E: wedc@lboro.ac.uk W: <http://wedc.lboro.ac.uk>

